

# TRG SERIES - STANDARD TURBINE FLOW METER

Ideal turbine flow meter for monitoring solvents and other lower viscosity fluids, such as antifreeze and fuel measurement.



## TECHNICAL SPECIFICATIONS

**Measuring Accuracy**  
± 1.0% of reading or better

**Repeatability**  
± 0.1%

**Flow Measuring Range**  
.08 to 200 GPM (gal/min)

**Turn Down Ratio**  
10:1

**Maximum Operating Pressure\***  
Working pressure up to 5,000 psi

**Maximum Operating Temperature**  
Fluid temperature of -150° to 450°F

**Standard Calibration Media**  
Tap water @ 70°F Temperature

**End Connections**  
NPT

\* Electronic sensor dependent.

## BENEFITS

### Rugged & Cost-Effective

The sturdy construction of this turbine flow meter means high performance and longer service life at an affordable price.

### Industry Standard

The TRG Series flow meter comes with a standard NPT end connection for universal applications.

### Versatile

This meter is capable of measuring flow in line sizes from 1/2" to 2".

### Electronic Integration

This meter can provide displayed flow rate, totalization, current or voltage outputs through a variety of compatible electronics.

### Simplified Maintenance

The TRG Series was designed with only one moving part for easy cleaning and maintenance.

### Explosion Proof (EX) Options Available

## MATERIALS OF CONSTRUCTION

<b>Rotor Support</b>	303 Stainless Steel
<b>Body</b>	316L Stainless Steel
<b>Rotor Shaft</b>	Tungsten Carbide
<b>Impeller</b>	420 Stainless Steel

## RECOMMENDED SENSORS

Model	Sensor Type	Temp (°F)
MAG-PB	Pulse Sensor - <i>No Amplifier Required</i>	-40 to 185
FIP-4HS	4-20 mA Output Sensor	-40 to 185
<b>Meter Mounted Displays:</b>		
<b>Non EX Meters</b>		
RT-10A	Battery-Powered monitor	0 to 140
RT-30 SD	24 VDC Powered monitor	0 to 140
<b>EX Meters</b>		
HUB-40EX	Hazardous area rated sensor	-40 to 140
RT-30EX	Hazardous area rated local flow rate transmitter	-6 to 140

\* For additional sensors available, contact factory. Other outputs available upon request.



©2016 AW-Lake Company. All rights reserved. Doc ID: TRGDS16 REV 4.20

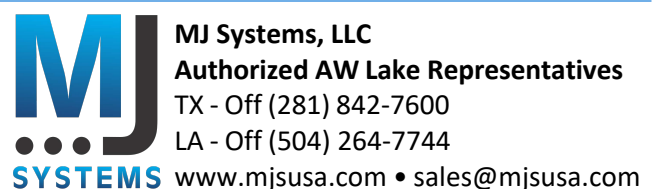

# TRG SERIES - STANDARD TURBINE FLOW METER

Ideal turbine flow meter for monitoring solvents and other lower viscosity fluids, such as antifreeze and fuel measurement.

## METER SPECIFICATIONS

Part Number	Flow Range (gal/min)	K-Factor* (pulses/gal)	Porting	Filtration (micron)	Pressure Rating (psi)	Weight (lbs)
TRG-11.250-5 (EX2) <sup>1</sup>	0.08 to 0.4	125,000	1/2" Male NPT	100	5,000	0.75
TRG-11.300-5 (EX2) <sup>1</sup>	0.13 to 1.06	91,500	1/2" Male NPT	100	5,000	0.75
TRG-11.375-5 (EX2) <sup>1</sup>	0.3 to 3	48,000	1/2" Male NPT	100	5,000	0.75
TRG-11.500-5 (EX2) <sup>1</sup>	0.9 to 9	15,000	1/2" Male NPT	100	5,000	0.75
TRG-11.750-5 (EX2) <sup>1</sup>	1.6 to 16	10,500	1/2" Male NPT	300	5,000	0.75
TRG-11.750 (EX2) <sup>1</sup>	1.6 to 16	10,500	1" Male NPT	300	5,000	1.25
TRG-11.880** (EX2) <sup>1</sup>	3.2 to 32	2,900	1" Male NPT	300	5,000	1.50
TRG-1110 (EX2) <sup>1</sup>	5.3 to 53	800	1-1/2" Male NPT	300	5,000	2.50
TRG-1120L (EX2) <sup>1</sup>	13 to 200	400	2" Male NPT	300	5,000	3.25

\*K-Factors given are averaged. A calibration sheet accompanies every meter sold. \*\*This is a direct replacement for the TRG-11.875 and has a doubled K-Factor.  
<sup>1</sup>EX2 versions available.

## METER DIMENSIONS

Part Number	A	B	C
TRG-11.250-5 (EX2) <sup>1</sup>	3.00"	1.35"	1.20"
TRG-11.300-5 (EX2) <sup>1</sup>	3.00"	1.35"	1.20"
TRG-11.375-5 (EX2) <sup>1</sup>	3.00"	1.35"	1.20"
TRG-11.500-5 (EX2) <sup>1</sup>	3.00"	1.35"	1.20"
TRG-11.750-5 (EX2) <sup>1</sup>	3.00"	1.35"	1.20"
TRG-11.750 (EX2) <sup>1</sup>	3.00"	1.55"	1.40"
TRG-11.880 (EX2) <sup>1</sup>	3.00"	1.55"	1.40"
TRG-1110 (EX2) <sup>1</sup>	3.00"	2.15"	1.95"
TRG-1120L (EX2) <sup>1</sup>	4.00"	2.70"	2.55"

<sup>1</sup>EX2 versions available.

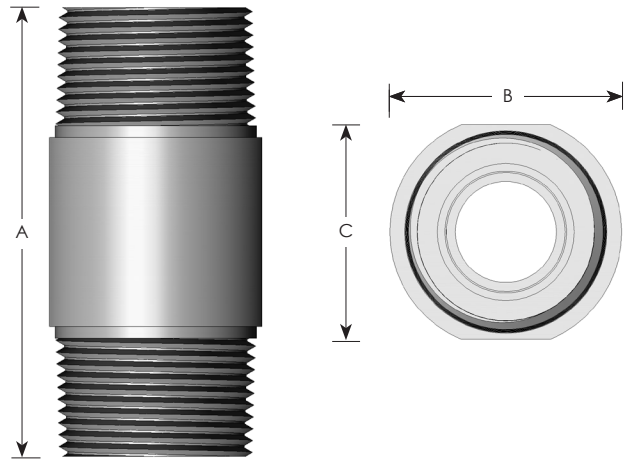

Products may be subject to change without notice - Contact factory for the most up-to-date product information.