



BLISS ANAND

Radar Transmitters



MJ Systems, LLC
Authorized Bliss Distributors
TX - Off (281) 842-7600
LA - Off (504) 264-7744
www.mjsusa.com • sales@mjsusa.com



BA Series Guided Wave Radar

Index:



BLISSFLEX 1100

- Product Features & Overview	04
- Applications	05
- Measuring Principle	06
- Technical Data	07 - 10



BLISSFLEX 2200

- Product Features & Overview	11 - 14
- Applications	15
- Measuring Principle	16
- Technical Data	17 - 31

BA Series Non-Contact Radar



BLISSWAVE 1010

- Product Features & Overview	32 - 33
- Measuring Principle	34
- Technical Data	35 - 39



BLISSWAVE 5200





- Product Features & Overview	40 - 43
- Applications	44 - 45
- Measuring Principle	46 - 47
- Technical Data	48 - 61

SELECTION GUIDE	62 - 77
-----------------	---------





CERTIFICATION	78 - 80
---------------	---------



RADAR TRANSMITTERS

BA Series	Guided Wave Radar		Non - Contact Radar	
	Blissflex 1100	Blissflex 2200	Blisswave 1010	Blisswave 5200
				
Measurement Type	2-Wire TDR Guided Radar for storage or process applications	2-Wire TDR Guided Radar for storage or process applications	2-Wire FMCW Radar welded to bypass chamber or Magnetic Level Indicator (MLI)	2-Wire FMCW Radar for liquid application
Measureable Products	Liquids & Solids	Liquids & Solids	Liquids	Liquids, Pastes & Slurries
Applications	<ol style="list-style-type: none"> Storage tank Still well/ Reference Chambers Process tanks 	<ol style="list-style-type: none"> Storage Tank Still Well/ Reference Chambers Process Tanks Complex Process Tanks (e.g. with agitators) 	<ol style="list-style-type: none"> Storage Tank Still Well/ Reference Chambers Process Tanks Complex Process Tanks (e.g. with agitators) 	<ol style="list-style-type: none"> Storage Tank Still Well/ Reference Chambers Process Tanks
Level	+/-	+/-	+	+
Measuring Range	0.7...20 m; 2.3...65.6 ft	0.6...40 m; 2...131 ft	≤8 m; ≤26.2 ft	1...30 m; 3.3...98 ft
Dielectric Constant ϵ_r	≥ 1.6	≥ 1.4 (1.1)	Not applicable; if $\epsilon_r < 3$, a float with a target is used	≥1.8
Accuracy	±10 mm; ±0.4	±3 mm; ±0.12 (calibration certificate)	±5 mm; ±0.2"	±5 mm; ±0.2
Outputs	mA	mA (HART®) FF/PROFIBUS® PA	mA (HART®)	mA (HART®) FF/PROFIBUS® PA
Power Supply	2-wire: 14...30 VDC	2-Wire: 12...30 VDC (non-Ex and Ex-i), 16...36 VDC (Ex d)	2-Wire: 14.5...36 VDC (non-Ex and Ex d), 14.5...30 VDC (Ex i)	2-Wire: 12...30 VDC (non-Ex and Ex i), 16...36 VDC (Ex d)
Housing Material	Aluminum	Aluminum, Stainless Steel	Aluminum, Stainless Steel	Aluminum, Stainless Steel
Ambient Temperature	-40...+80°C; -40...+176°F	-40...+80°C; -40...+176°F	-40...+85°C; -40...+185°F	-40...+80°C; -40...+176°F
Protection Category	IP66/67	IP66/67; NEMA4X/6	IP66/67	IP66/67; NEMA4X/6



BA Series	Guided Wave Radar		Non - Contact Radar	
	Blissflex 1100	Blissflex 2200	Blisswave 1010	Blisswave 5200
				
Flange System				
Process Connection				
Thread	G $\frac{3}{4}$ or G1; $\frac{3}{4}$ " NPT or 1" NPT	G $\frac{1}{2}$...1 $\frac{1}{2}$; $\frac{1}{2}$...1 $\frac{1}{2}$ " NPT	G $\frac{1}{2}$; $\frac{1}{2}$ " NPT (bypass chamber)	G1 $\frac{1}{2}$...2; 1 $\frac{1}{2}$...2" NPT
EN	Screw-on Flanges available as accessories	DN25...150 in PN10...40 DN200 in PN16,40 others on request	DN15...50; PN40 (bypass chamber)	DN50...200; PN16, 40
ASME	Screw-on Flanges available as accessories	1...8" in 150 lb/300 lb others on request	$\frac{1}{2}$...2"; 150 lb, 300 lb (bypass chamber)	2...8"; 150 lb, 300 lb
JIS	Screw-on flanges available as accessories	40...200A in 10K others on request	-	50...200A in 10K
Pressure Range				
Process	-1...16 barg; -14.5...232 psig	-1...40 barg; -14.5...580 psig	-1...40 barg; -14.5...580 psig	-1...40 barg; -14.5...580 psig, higher on request
Temperature Range				
Process	-50...+100°C; -58...+212°F	-50...+150°C; -58...+302°F, optional +300°C; +572°F	-40...+150°C; -40...302°F	-60...+250°C; -76...+482°F, higher on request
Materials				
Wetted Parts	Cable: Stainless Steel 1.4404 (316) Coaxial: Stainless Steel 1.4435/1.4404 (316L)	Stainless Steel, Hastelloy®, others on request	Stainless Steel, PEEK cone	Stainless Steel, PP, PTFE, others on request
Materials				
Gaskets	EPDM	FKM/FPM, Kalrez® 6375, EPDM, others on request	FKM/FPM, Kalrez® 6375, EPDM, others on request	FKM/FPM, Kalrez® 6375, EPDM, others on request
Approvals				
Ex	-	ATEX, IECEx, cFMus	ATEX, IECEx, FM (pending)	ATEX, IECEx, cFMus
Miscellaneous	-	SIL2, NACE MR0175; NACE MR0103	NACE MR0175; NACE MR0103	SIL2, NACE MR0175; NACE MR0103



RADAR TRANSMITTERS

BLISSFLEX 1100

PRODUCT FEATURES AND OVERVIEW

THE COST-EFFECTIVE TDR SOLUTION

BLISSFLEX 1100 C is a 2-Wire TDR level meter for measuring distance, level, volume and mass of liquids and solids. Its simple, compact design allows service technicians to quickly assemble the probe and attach it to a threaded connection. It is an affordable solution for applications that do not require a high level of accuracy and is also an excellent alternative to traditional level controls such as RF Capacitance, conductive and DP transmitters.

1. Aluminium housing with optional LCD display screen
2. Converter is rotatable and removable under process conditions
3. Threaded Connection (NPT or G)
4. Choice of Cable or Coaxial Probe
5. 2-Wire loop-powered level meter



OPTIONAL INTEGRATED DISPLAY

The display can be ordered with the device or as an accessory. It shows measurement data on a 128 × 64 pixel screen. The configuration menu permits the device to be set up in a small number of intuitive steps.

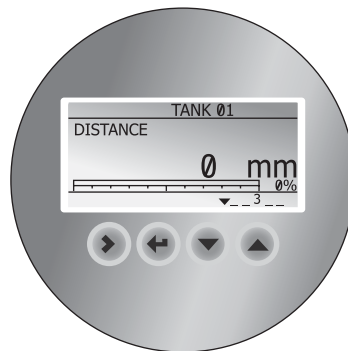

HIGHLIGHTS

- 2-Wire loop-powered level meter for liquids and solids
- For general-purpose use (Non-Hazardous areas)
- Measuring range up to 20 m / 65.6 ft (liquids) and 10 m / 32.8 ft (solids)
- Easy menu navigation without opening the housing
- Probes and Process Connections are made of stainless steel
- For process temperatures up to 100°C / 210°F and pressures up to 16 barg / 232 psig
- Display in 9 languages: including Chinese, Japanese and Russian



BLISSFLEX 1100

APPLICATIONS

- Level measurement in buffer tanks, collectors and simple process applications
- Silo level monitoring in quarrying and agriculture
- Volume measurement for storage tanks (with a 30-point strapping table)

APPLICATION TABLE FOR PROBE SELECTION

	Segmented Coaxial Ø14 mm / 0.55"	Single Cable Ø2 mm / 0.08"	Single Cable Ø4 mm / 0.15"
--	-------------------------------------	-------------------------------	-------------------------------

Maximum Probe Length, L

4m / 13.1 ft	S	X	X
10 m / 32.8 ft	X	X	S
20 m / 65.6 ft	X	S	X

Liquids

Liquid Applications, ≤ 10000 mPa.s ($\epsilon_r \geq 2.1$)	X	S	X
Liquid Applications, ≤ 500 mPa.s ($\epsilon_r \geq 1.6$)	S	X	X
Storage Tanks	S	S	S
Installation in a bypass chamber	S	S	S
Installation in a Stilling Well	S	S	S

Solids

Powders ($\epsilon_r \geq 2.1$)	X	X	S
Granules, $< \text{Ø}5$ mm / 0.2" ($\epsilon_r \geq 2.1$)	X	X	S

S Standard X on Request



RADAR TRANSMITTERS

BLISSFLEX 1100

MEASURING PRINCIPLE

This Guided Radar (TDR) level meter has been developed from a proven technology called Time Domain Reflectometry (TDR).

The device transmits low-intensity electromagnetic pulses of approximately one nanosecond width along a rigid or flexible conductor. These pulses move at the speed of light. When the pulses reach the surface of the product to be measured, the pulses are reflected back to the signal converter.

The device measures the time from when the pulse is transmitted to when it is received: half of this time is equivalent to the distance from the reference point of the device to the surface of the product. The time value is converted into an output current of 4...20 mA.

Dust, foam, vapour, agitated surfaces, boiling surfaces, changes in pressure, changes in temperature, changes in dielectric constant and changes in density do not have an effect on device performance.

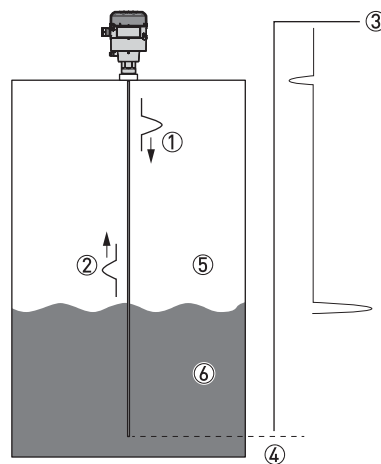

TDR Measurement of Level

- 1 Transmitted Pulses
- 2 Reflected Pulse
- 3 Pulse Amplitude
- 4 Time of Flight
- 5 Air, $\epsilon_r = 1$
- 6 Liquid, $\epsilon_r \geq 1.6$. Solid, $\epsilon_r \geq 2.1$.



BLISSFLEX 1100

TECHNICAL DATA

- The following data is provided for general applications. If you require data that is more relevant to your specific application, please contact us or your local representative.
- Complete product documentation can be provided on request.

Converter

MEASURING SYSTEM

Application	Level and volume measurement of liquids, pastes, powders and granulates
Measuring Principle	TDR (time domain reflectometry)
Construction	Measuring probe attached directly to a signal converter

OPERATING CONDITIONS

Ambient Temperature	-40...+80°C / -40...+176°F Integrated LCD display: -20...+60°C / -5...+140°F; if the ambient temperature is not in these limits, the display switches off
Storage Temperature	-50...+85°C / -60...+185°F
Protection Category	IP 66/67

MATERIALS

Housing	Polyester-Coated Aluminum
Cable Entry	M20 × 1.5 (F) (plastic cable gland included) or ½ NPT (F) (without cable gland)

ELECTRICAL CONNECTIONS

Power Supply (terminals)	14...30 VDC
Current Output Load	$RL [\Omega] \leq ((U_{ext} - 14 V) / 22 \text{ mA})$. For more data, refer to Minimum Power Supply Voltage.
Cable Entry Capacity (terminal)	0.5...1.5 mm ²

INPUT AND OUTPUT

Measured Variable	Time between the emitted and received signal
Output Signal	4...20 mA or 3.8...20.5 mA
Resolution	±1 µA
Error Signal Options	High: 22 mA; Low: 3.6 mA Hold (frozen value)

DISPLAY AND USER INTERFACE

User Interface Options	LCD display (128 × 64 pixels in 8-step greyscale with 4-button keypad)
Languages	9 languages are available: English, German, French, Italian, Spanish, Portuguese, Japanese, Chinese (Mandarin) and Russian



RADAR TRANSMITTERS

BLISSFLEX 1100

Probe Options

	Segmented Coaxial Ø14 mm / 0.55"	Single Cable Ø2 mm / 0.08"	Single Cable Ø4 mm / 0.15"
--	-------------------------------------	-------------------------------	-------------------------------

MEASURING SYSTEM

Application	Level Measurement of Liquids		Level Measurement of Solids
Measuring Range	0.73...4.067 m / 2.4...13.3 ft ①	1...20 m / 3.3...65.6 ft	1...10 m / 3.3...32.8 ft
Dead Zone	This depends on the type of Probe. For more data, refer to Measurement limits.		

MEASURING ACCURACY

Accuracy	±10 mm / ±0.4", when distance ≤ 10 m / 33 ft; ±0.1% of measured distance, when distance >10m/ 33 ft	±20 mm / ±0.8"
Resolution	1 mm/ 0.04"	
Repeatability	±2 mm/ ±0.08"	
Maximum rate of change at 4 mA	10 m/min / 32.8 ft/min	

OPERATING CONDITIONS

Temperature	-50...+100°C/ -60...+212°F		
Pressure	-1...16 barg / -14.5...232 psig		
Viscosity	≤500 mPa.s	10000 mPa.s	n/a
Dielectric Constant	≥ 1.6	≥ 2.1	≥ 2.1

MATERIALS

Probe	Stainless Steel (1.4404 / 316L)	Stainless Steel (1.4401 / 316)	Stainless Steel (1.4401 / 316)
Gasket (Process Seal)	EPDM		
Process Connection	Stainless Steel (1.4404 / 316L)		

PROCESS CONNECTIONS

Thread	G ¾...1A; ¾...1 NPT
--------	---------------------

- ① The Coaxial Probe can be supplied in 6 standard lengths:
730 mm / 29", 1397 mm / 55", 2065 mm / 81", 2732 mm / 108", 3400 mm / 134" or 4067 mm / 160".
If necessary, shorten the probe. For more data, contact us.

BLISSFLEX 1100

DIMENSIONS AND WEIGHTS

Converter

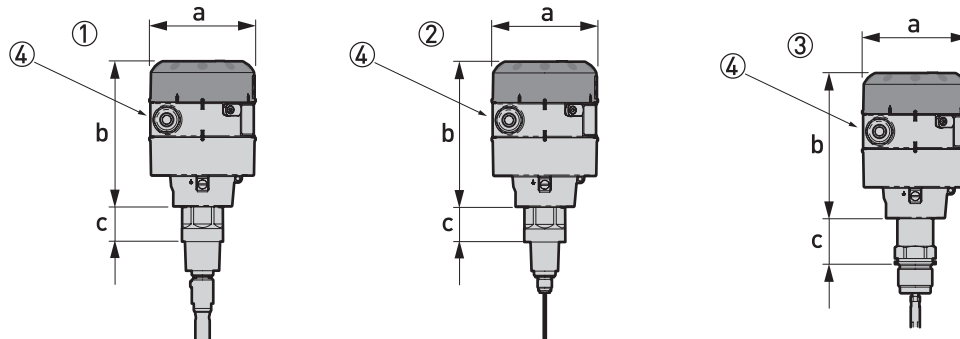

Converter Dimensions

1. Converter with a Coaxial Probe
2. Converter with a $\varnothing 2$ mm / 0.08" Single Cable Probe
3. Converter with a $\varnothing 4$ mm / 0.15" Single Cable Probe
4. The diameter of the outer sheath of the cable must be 6...12 mm or 0.23...0.47" (cable entry size M20 \times 1.5 (F))

Dimensions and Weights

	Dimensions						Weights	
	$\varnothing a$		b		c		[kg]	[lb]
	[mm]	[inches]	[mm]	[inches]	[mm]	[inches]		
1 and 2	104	4.1	141	5.6	34	1.3	3.3	7.3
3	104	4.1	141	5.6	45	1.8	3.3	7.3



RADAR TRANSMITTERS

BLISSFLEX 1100

Probes

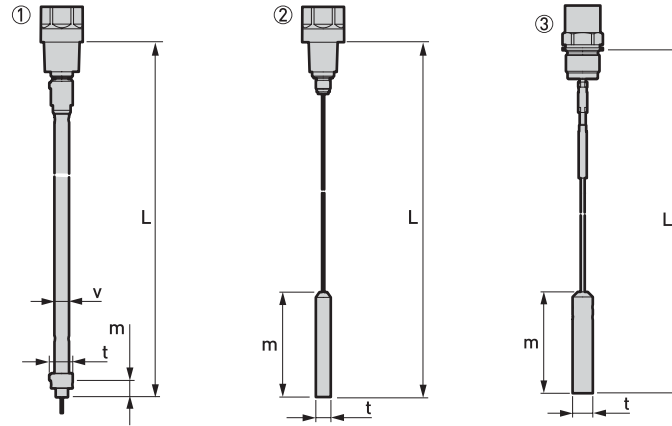

Probe Dimensions

L is the total length of the Probe. This includes the length of the counterweight for Cable Probes and the Probe End Cap for Coaxial Probes.

m is the length of the counterweight or the bottom of the Probe End Cap for Coaxial Probes

1. Ø14 mm / Ø0.55" Coaxial Probe
2. Ø2 mm / Ø0.08" Single Cable Probe
3. Ø4 mm / Ø0.15" Single Cable Probe

Probes: Dimensions and Weights in mm and kg

Probe	Dimensions (mm)					Weights (kg)
	L min.	L max.	m	t	v	
Coaxial Ø14 mm	730 ①	4067 ②	15	Ø21	Ø14	0.45 ③
Single Cable Ø2 mm	1000 ①	20000	100	Ø14	-	0.4
Single Cable Ø4 mm	1000 ①	10000	100	Ø20	-	1.2

- ① All the Probes can be shortened on site
- ② The Coaxial Probe can be supplied in 6 standard lengths: 730 mm, 1397 mm, 2065 mm, 2732 mm, 3400 mm or 4067 mm
- ③ This is the weight for each segment of the Coaxial Probe

Probes: Dimensions in inches and lb

Probe	Dimensions (Inches)					Weights (lb)
	L min.	L max.	m	t	v	
Coaxial Ø0.55"	29 ①	160 ②	0.6	Ø0.8	Ø0.55	0.30 ③
Single Cable Ø0.08"	40 ①	787	4.0	Ø0.5	-	0.88
Single Cable Ø0.15"	40 ①	394	4.0	Ø0.8	-	2.64

- ① All the Probes can be shortened on site
- ② The Coaxial Probe can be supplied in 6 standard lengths: 29", 55", 81", 108", 134" or 160"
- ③ This is the weight for each segment of the Coaxial Probe

BLISSFLEX 2200

PRODUCT FEATURES AND OVERVIEW

THE MODULAR TDR LEVEL TRANSMITTER

This device is a TDR level transmitter for measuring distance, level, volume and mass. Its modular design makes it an economical and reliable solution for common applications.

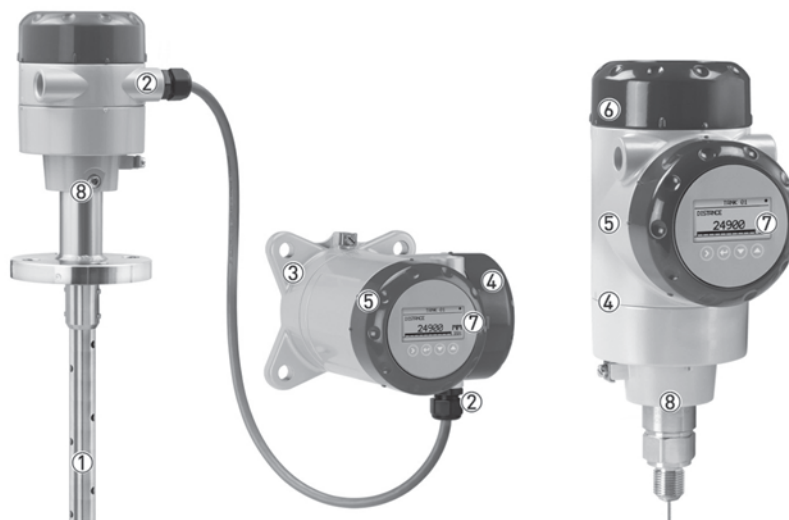

1. Large choice of Probes to cover a vast range of applications
2. Optional remote converter can be installed up to 100 m / 328 ft away from the Probe
3. Wall Support
4. Horizontal / Vertical Housings and Segmented Probe options makes the device suitable for many applications and for installation in a variety of positions
5. Aluminum or Stainless Steel Housing
6. 2-Wire Level Transmitter
7. Optional LCD display with 4-button keypad
8. Converter is rotatable and removable under process conditions



RADAR TRANSMITTERS

BLISSFLEX 2200

OPTIONAL INTEGRATED DISPLAY

The display can be ordered with the device or as an accessory. It shows measurement data on a 128 × 64 pixel screen. The configuration menu permits the device to be set up in a small number of intuitive steps.

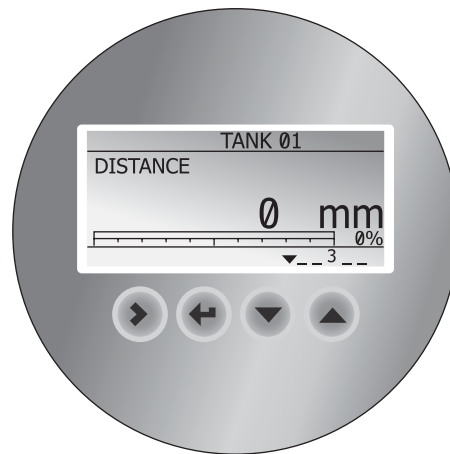

HIGHLIGHTS

- 2-Wire Loop-Powered HART® TDR level transmitter for liquids and solids
- DPR (Dynamic Parasite Rejection): the software dynamically eliminates false reflections caused by environmental disturbances and product build-up
- Quick coupling system permits removal of the converter under process conditions and 360° rotation to make the display screen easier to read
- Horizontal and vertical housing position to suit every installation
- The remote converter can be installed up to 100 m / 328 ft from the Probe
- Display keypad is directly accessible without opening the cover
- Measuring range up to 40 m / 131 ft
- Converter backwards compatible with all flange systems of current and previous generation TDR level transmitters
- SIL2-compliant according to IEC 61508 for safety-related systems
- The device has FDT1.2 DTM certification.

BLISSFLEX 2200

OVERVIEW

BLISSFLEX 2200 C - Compact /
Vertical Version



This version makes it easier to read and operate devices installed on a tank roof or in a recess

BLISSFLEX 2200 C - Compact /
Horizontal Version



This version is ideal for installation in locations with low roofs.

BLISSFLEX 2200 F - Remote Version

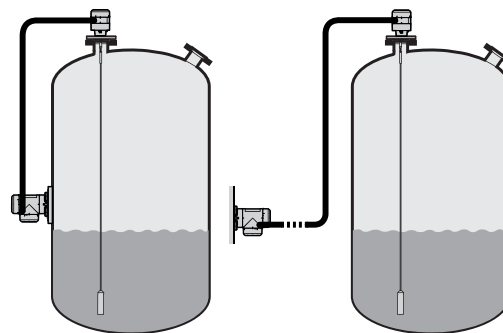

This version has a separate converter with a display which can be mounted and read off at the bottom of the tank or even at a distance of up to 100 m / 328 ft from the sensor.



RADAR TRANSMITTERS

BLISSFLEX 2200

WEATHER PROTECTION

A weather protection option can also be ordered with the device. It is recommended for outdoor applications.



- Must be ordered with the device.
- Can be ordered for both compact versions of the device and the probe housing of the remote version.
- Easily opened and closed.



BLISSFLEX 2200

Applications

- Liquid level measurement in process tanks for various chemical products
- Liquid and solid volume measurement for storage tanks

Application Table For Probe Selection

	Double Rod	Single Rod	Single Rod (Segmented)	Coaxial	Coaxial (Segmented)	Double Cable	Single Cable Ø4 mm / 0.15"	Single Cable Ø2 mm / 0.08"	Single Cable Ø8 mm / 0.32"
--	------------	------------	------------------------	---------	---------------------	--------------	----------------------------	----------------------------	----------------------------

Maximum Probe Length, L

4m/ 13 ft									
6m/ 20 ft									
28 m / 92 ft									
40 m / 131 ft									

Liquids

Liquid Application									
LPG, LNG		1	1				1	1	
Highly Viscous Liquids									
Highly Crystallising Liquids									
Highly Corrosive Liquids		2	3						
Foam									
Agitated Liquids	4	4	4	4	4	4	4	4	
Spray in Tank		1	1				1	1	
Storage Tanks									
Installation in bypass Chamber									
Small Diameter Nozzles and Long Nozzles		4	4				4	4	
Stilling Wells									

Solids

Powders							5		
Granules, <5 mm / 0.2"							5		

■ J standard ■ on request

1. Install the device in a stilling well or a bypass chamber
2. Make a selection from one of these 2 options: a Probe made of HASTELLOY® C-22® or a Probe with a PVC, PVDF or PP protective sheath
3. Use a probe made of HASTELLOY® C-22®
4. Use this Probe with an anchor fitting. For more data, refer to the handbook.
5. Max. length is 20 m / 65.5 ft, more on request



RADAR TRANSMITTERS

BLISSFLEX 2200

MEASURING PRINCIPLE

This Guided Radar (TDR) level transmitter has been developed from a proven technology called Time Domain Reflectometry (TDR).

The device transmits low-intensity electromagnetic pulses of approximately one nanosecond width along a rigid or flexible conductor. These pulses move at the speed of light. When the pulses reach the surface of the product to be measured, the pulses are reflected back to the signal converter.

The device measures the time from when the pulse is emitted to when it is received: half of this time is equivalent to the distance from the reference point of the device to the surface of the product. The time value is converted into an output current of 4...20 mA.

Dust, foam, vapour, agitated surfaces, boiling surfaces, changes in pressure, changes in temperature, changes in dielectric constant and changes in density do not have an effect on device performance.

The illustration that follows shows a snapshot of what a user would see on an oscilloscope, if the level of one product is measured.

TDR Measurement of Level

- 1 Transmitted Pulses
- 2 Reflected Pulse
- 3 Pulse Amplitude
- 4 Time of Flight
- 5 Air, $\epsilon_r=1$
- 6 $\epsilon_r \geq 1.4$ in direct mode or $\epsilon_r \geq 1.1$ in TBF mode

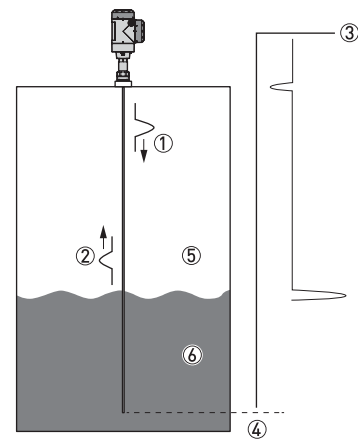

TDR measurement of level



BLISSFLEX 2200

TECHNICAL DATA

- The following data is provided for general applications. If you require data that is more relevant to your specific application, please contact us or your local sales office.
- Additional information (certificates, special tools, software,...) and complete product documentation can be provided on request

Converter

MEASURING SYSTEM

Application	Level and Volume measurement of Liquids, Pastes, Powders and Granulates
Measuring Principle	TDR (Time Domain Reflectometry)
Construction	Compact (C) version: Measuring Probe attached directly to a signal converter Remote (F) version: Measuring Probe installed on a tank and connected by a signal cable (max. length 100 m / 328 ft) to a signal converter

OPERATING CONDITIONS

Ambient Temperature	-40...+80°C / -40...+176°F Integrated LCD display: -20...+60°C / -5...+140°F; if the ambient temperature is not in these limits, the display switches off. The device continues to operate correctly.
Storage Temperature	-50...+85°C / -60...+185°F (min. -40°C / -40°F for devices with the integrated LCD display option)
Ingress Protection	IEC 60529: IP66 / IP67 NEMA 250: NEMA type 4X (Housing) and type 6P (Probe)

MATERIALS

Housing	Polyester-Coated Aluminum or Stainless Steel (1.4404 / 316L)
Cable Entry	Plastic; Nickel-Plated Brass, Stainless Steel

ELECTRICAL CONNECTIONS

Power Supply (Terminals)	Terminals Output – Non-Ex / Ex i: 11.5...30 VDC; min./max. value for an output of 22 mA at the terminal
	Terminals output – Ex d: 13.5...36 VDC; min./max. value for an output of 22 mA at the terminal
Current Output Load	Non-Ex / Ex i: $RL [Ω] ≤ ((U_{ext} - 11.5 V) / 22 \text{ mA})$.
	Ex d: $RL [Ω] ≤ ((U_{ext} - 13.5 V) / 22 \text{ mA})$.
Cable Entry	M20×1.5 (F); ½ NPT (F)
Cable Gland	Standard: none
	Options: M20×1.5 (cable diameter (non-Ex / Ex i: 6...7.5 mm / 0.24...0.30"; Ex d: 6...10 mm / 0.24...0.39"); others are available on request
Signal Cable - Remote Version	None for Non-Ex devices (4-wire shielded cable of max. length 100 m / 328 ft to be supplied by the customer). Supplied with all Ex-approved devices. For more data, refer to the handbook
Cable Entry Capacity (Terminal)	0.5...2.5 mm ²



RADAR TRANSMITTERS

BLISSFLEX 2200

INPUT AND OUTPUT

Current Output / HART®	
Output Signal	4...20 mA HART® or 3.8...20.5 mA acc. to NAMUR NE 43 ①
Resolution	±3 µA
Temperature Drift (Analog)	Typically 50 ppm/K
Temperature Drift (Digital)	Max. ±15 mm for the full temperature range
Error Signal Options	High: 22 mA; Low: 3.6 mA acc. to NAMUR NE 43; Hold (Frozen Value - not available if the output agrees with NAMUR NE 43) ②
PROFIBUS PA	
Type	PROFIBUS MBP interface that agrees with IEC 61158-2 with 31.25 kbit/s; voltage mode (MBP = Manchester-Coded, Bus-Powered)
Function Blocks	1 × Physical Block, 1 × Level Transducer Block, 4 × Analog Input Function Blocks
Device Power Supply	9...32 VDC - bus powered; no additional power supply required
Polarity Sensitivity	No
Basic Current	15 mA
FOUNDATION™ fieldbus	
Physical Layer	FOUNDATION™ fieldbus protocol that agrees with IEC 61158-2 and FISCO model
Communication Standard	H1
ITK Version	6.1
Function Blocks	1 × Resource Block (RB), 3 × Transducer Blocks (TB), 3 × Analog Input Blocks (AI), 1 × Proportional Integral Derivative Block (PID)
	Analog Input Block: 30 ms
	Proportional Integral Derivative Block: 40 ms
Device Power Supply	Not Intrinsically safe: 9...32 VDC Intrinsically safe: 9...24 VDC
Basic Current	14 mA
Maximum Error Current FDE	20.5 mA (= basic current + error current = 14 mA + 6.5 mA)
Polarity Sensitivity	No
Minimum Cycle Time	250 ms
Output Data	Level, Distance, Ullage Conversion, Level Conversion
Input Data	None
Link Active Scheduler	Supported

DISPLAY AND USER INTERFACE

User Interface Options	LCD display (128 × 64 pixels in 8-step greyscale with 4-button keypad)
Languages	9 languages are available: English, German, French, Italian, Spanish, Portuguese, Japanese, Chinese (simplified) and Russian



BLISSFLEX 2200

APPROVALS AND CERTIFICATION

Explosion Protection	
ATEX (Ex ia, Ex d or Ex tb) DEKRA 11ATEX0166 X	Compact Version
	II 1/2 G, 2 G Ex ia IIC T6...T2 Ga/Gb or Ex ia IIC T6...T2 Gb;
	II 1/2 D, 2 D Ex ia IIIC T90°C Da/Db or Ex ia IIIC T90°C Db IP6X;
	II 1/2 G, 2 G Ex d ia IIC T6...T2 Ga/Gb or Ex d ia IIC T6...T2 Gb;
	II 1/2 D, 2 D Ex ia tb IIIC T90°C Da/Db or Ex ia tb IIIC T90°C Db IP6X
	Remote Version, Transmitter
	II 2 G Ex ia [ia Ga] IIC T6...T4 Gb;
	II 2 D Ex ia [ia Da] IIIC T90°C Db;
	II 2 G Ex d ia [ia Ga] IIC T6...T4 Gb;
	II 2 D Ex ia tb [ia Da] IIIC T90°C Db
	Remote Version, Sensor
	II 1/2 G Ex ia IIC T6...T2 Ga/Gb
	II 1/2 D Ex ia IIIC T90°C Da/Db
	II 1/2 G Ex ia IIC T6...T2 Gb
II 1/2 D Ex ia IIIC T90°C Db	
ATEX (Ex ic) DEKRA 13ATEX0051 X	Compact Version
	II 3 G Ex ic IIC T6...T2 Gc;
	II 3 D Ex ic IIIC T90°C Dc
	Remote Version, Transmitter
	II 3 G Ex ic [ic] IIC T6...T4 Gc;
	II 3 D Ex ic [ic] IIIC T90°C Dc
	Remote Version, Sensor
	II 3 G Ex ic IIC T6...T2 Gc;
II 3 D Ex ic IIIC T90°C Dc	
IECEX IECEX DEK 11.0060 X	Compact Version
	Ex ia IIC T6...T2 Ga/Gb or Ex ia IIC T6...T2 Gb or Ex ic IIC T6...T2 Gc;
	Ex ia IIIC T90°C Da/Db or Ex ia IIIC T90°C Db or Ex ic IIIC T90°C Dc;
	Ex d ia IIC T6...T2 or Ex d ia IIIC T6...T2 Gb;
	Ex ia tb IIIC T90°C Da/Db or Ex ia tb IIIC T90°C Db
	Remote Version, Transmitter
	Ex ia [ia Ga] IIC T6...T4 Gb or Ex ic IIC T6...T4 Gc;
	Ex ia [ia Da] IIIC T90°C Db or Ex ic [ic] IIIC T90°C Dc;
	Ex d ia [ia Ga] IIC T6...T4 Gb;
	Ex ia tb [ia Da] IIIC T90°C Db
	Remote Version, Sensor
	Ex ia IIC T6...T2 Ga/Gb or Ex ia IIC T6...T2 Gb or Ex ic IIC T6...T2 Gc;
Ex ia IIIC T90°C Da/Db or Ex ia IIIC T90°C Db or Ex ic IIIC T90°C Dc	



RADAR TRANSMITTERS

BLISSFLEX 2200

cFMus – Dual Seal-approved	NEC 500 (Division ratings)
	XP-AIS / Cl. I / Div. 1 / Gr. ABCD / T6–T1;
	DIP / Cl. II, III / Div. 1 / Gr. EFG / T90°C;
	IS / Cl. I, II, III / Div. 1 / Gr. ABCDEFG / T6–T1;
	NI / Cl. I / Div. 2 / Gr. ABCD / T6–T1
	NEC 505 and NEC 506 (Zone ratings)
	Cl. I / Zone 0 / AEx d [ia] / IIC / T6–T1;
	Cl. I / Zone 0 / AEx ia / IIC / T6–T1;
	Cl. I / Zone 2 / AEx nA / IIC / T6–T1;
	Cl. I / Zone 2 / AEx ic / IIC / T6–T1 FISCO;
	Zone 20 / AEx ia / IIIC / T90°C
	Zone 20 / AEx tb [ia] / IIIC / T90°C
	Hazardous (Classified) Locations, indoor/outdoor Type 4X and 6P, IP66, Dual Seal
	CEC Section 18 (Zone ratings)
	Cl. I, Zone 0, Ex d [ia], IIC, T6–T1;
	Cl. I, Zone 0, Ex ia, IIC, T6–T1;
	Cl. I, Zone 2, Ex nA, IIC, T6–T1;
	Cl. I, Zone 2, Ex ic, IIC, T6–T1 FISCO
	CEC Section 18 and Annex J (Division ratings)
	XP-AIS / Cl. I / Div. 1 / Gr. BCD / T6–T1
	DIP / Cl. II, III / Div. 1 / Gr. EFG / T6–T1
	IS / Cl. I / Div. 1 / Gr. BCD / T6–T1
	NI / Cl. I / Div. 2 / Gr. ABCD / T6–T1
	Ex ia tb IIIC T90°C Da/Db or Ex ia tb IIIC T90°C Db
	Remote Version, Transmitter
	Ex ia [ia Ga] IIC T6...T4 Gb or Ex ic IIC T6...T4 Gc;
	Ex ia [ia Da] IIIC T90°C Db or Ex ic [ic] IIIC T90°C Dc;
	Ex d ia [ia Ga] IIC T6...T4 Gb;
	Ex ia tb [ia Da] IIIC T90°C Db
	Remote Version, Sensor
	Ex ia IIC T6...T2 Ga/Gb or Ex ia IIC T6...T2 Gb or Ex ic IIC T6...T2 Gc;
	Ex ia IIIC T90°C Da/Db or Ex ia IIIC T90°C Db or Ex ic IIIC T90°C Dc



BLISSFLEX 2200

Other Standards and Approvals	
SIL	Compact Version only; SIL 2 – certified according to all the requirements in EN 61508 (Full Assessment) and for high/low demand mode operation. HFT=0, SFF=94.3% (for Non-Ex / Ex i devices) or 92.1% (for Ex d devices), type B device
NAMUR	NAMUR NE 21 Electromagnetic Compatibility (EMC) of Industrial Process and Laboratory Control Equipment
	NAMUR NE 43 Standardization of the Signal Level for the Failure Information of Digital Transmitters
	NAMUR NE 53 Software and Hardware of Field Devices and Signal Processing Devices with Digital Electronics
	NAMUR NE 107 Self-Monitoring and Diagnosis of Field Devices
Construction Code	On Request: NACE MR0175 / ISO 15156; NACE MR0103

- ① HART® is a registered trademark of the HART Communication Foundation
- ② Only the 3.6 mA error signal is applicable to SIL-Approved devices

Probe Options

	Single Cable Ø2 mm / 0.08"	Single Cable Ø4 mm / 0.16"	Single Rod Ø8 mm / 0.32"	Single Cable Ø8 mm / 0.32"

MEASURING SYSTEM

Application	Liquids	Liquids and Solids		Solids
Measuring Range	1...40 m / 3.28...131.23 ft	Liquids: 1...40 m / 3.28...131.23 ft Solids: 1...20 m / 3.28...65.62 ft	1...6 m / 3.28...19.7 ft	1...40 m / 3.28...131.23 ft
Dead Zone	This depends on the type of Probe.			

MEASURING ACCURACY

Accuracy (in direct mode)	Standard (liquids and solids): ±10 mm / ±0.4", when distance ≤ 10 m / 33 ft; ±0.1% of measured distance, when distance > 10 m / 33 ft
	Optional (liquids and solids): ±3 mm/ ±0.1", when distance ≤ 10 m / 33 ft; ±0.03% of measured distance, when distance > 10 m / 33 ft
Accuracy (in TBF mode)	±20 mm / ±0.8"
Resolution	1 mm/ 0.04"
Repeatability	±1 mm/ ±0.04"
Maximum rate of change at 4 mA	10 m/min / 32.8 ft/min



RADAR TRANSMITTERS

BLISSFLEX 2200

PROBE OPTIONS

	Single Cable Ø2 mm / 0.08"	Single Cable Ø4 mm / 0.16"	Single Rod Ø8 mm / 0.32"	Single Cable Ø8 mm / 0.32"
--	-------------------------------	-------------------------------	-----------------------------	-------------------------------

OPERATING CONDITIONS

Min./Max. temperature at the Process Connection (also depends on the temperature limits of the gasket material. Refer to "Materials" in this table.)	-50...+300°C/ -58...+572°F	-50...+150°C / -58...+302°F
Pressure	-1...40 barg / -14.5...580 psig	
Viscosity (liquids only)	10000 mPa.s / 10000 cP	
Dielectric Constant	≥ 1.8 in direct mode; ≥ 1.1 in TBF mode	

MATERIALS

Probe	Stainless Steel (1.4404 / 316L); HASTELLOY® C-22® (2.4602)	Stainless Steel (1.4401 / 316)	Stainless Steel (1.4404 / 316L)	Stainless Steel (1.4401 / 316)
Gasket (Process Seal)	FKM/FPM (-40...+300°C / -40...+572°F); Kalrez® 6375 (-20...+300°C / -4...+572°F); EPDM (-50...+250°C / -58...+482°F) ①	FKM/FPM (-40...+150°C / -40...+302°F); Kalrez® 6375 (-20...+150°C / -4...+302°F); EPDM (-50...+150°C / -58...+302°F) ①		
Process Connection	Stainless Steel (1.4404 / 316L); HASTELLOY® C-22® (2.4602)			

PROCESS CONNECTIONS

Thread	For more data options, refer to Order Code.
Flange	For more data options, refer to Order Code.

① Kalrez® is a registered trademark of DuPont Performance Elastomers L.L.C.



BLISSFLEX 2200

	Double Cable 2 × Ø4mm / 0.16"	Double Rod 2 × Ø8 mm / 0.32"	Coaxial Ø22 mm / 0.87"
Maximum rate of change at 4 mA 10 m/min / 32.8 ft/min			

MEASURING SYSTEM

Application	Liquids		
Measuring Range	1...28 m / 3.28...91.86 ft	1...4 m / 3.3...13.12 ft	0.6...6 m / 1.97...19.69 ft
Dead Zone	This depends on the type of Probe.		

MEASURING ACCURACY

Accuracy (in direct mode)	Standard (liquids and solids): ±10 mm / ±0.4 inch", when distance ≤ 10 m / 33 ft; ±0.1% of measured distance, when distance > 10 m / 33 ft
	Optional (liquids and solids): ±3 mm / ±0.1", when distance ≤ 10 m / 33 ft; ±0.03% of measured distance, when distance > 10 m / 33 ft
Accuracy (in TBF mode)	±20 mm / ±0.8"
Resolution	1 mm / 0.04"
Repeatability	±1 mm / ±0.04"

	Double Cable 2 × Ø4mm / 0.16"	Double Rod 2 × Ø8 mm / 0.32"	Coaxial Ø22 mm / 0.87"
--	----------------------------------	---------------------------------	---------------------------

OPERATING CONDITIONS

Min./Max. temperature at the process connection (also depends on the temperature limits of the gasket material. Refer to "Materials" in this table.)	-50...+150°C / -58...+302°F		
Pressure	-1...40 barg / -14.5...580 psig		
Viscosity (liquids only)	10000 mPa.s / 10000 cP	1500 mPa.s / 1500 cP	500 mPa.s / 500 cP
Dielectric constant	≥ 1.6 in direct mode		≥ 1.4 in direct mode
	≥ 1.1 in TBF mode		

MATERIALS

Probe	Stainless Steel (1.4404 / 316L)	Stainless Steel (1.4401 / 316); HASTELLOY® C-22® (2.4602)
Gasket (Process Seal)	FKM/FPM (-40...+150°C / -40...+302°F); Kalrez® 6375 (-20...+150°C / -4...+302°F); EPDM (-50...+150°C / -58...+302°F) ①	
Process Connection	Stainless Steel (1.4404 / 316L); HASTELLOY® C-22® (2.4602)	

PROCESS CONNECTIONS

Thread	For more data options, refer to Order Code.
Flange	For more data options, refer to Order Code.

① Kalrez® is a registered trademark of DuPont Performance Elastomers L.L.C.



RADAR TRANSMITTERS

BLISSFLEX 2200

DIMENSIONS AND WEIGHTS

Housing Dimensions

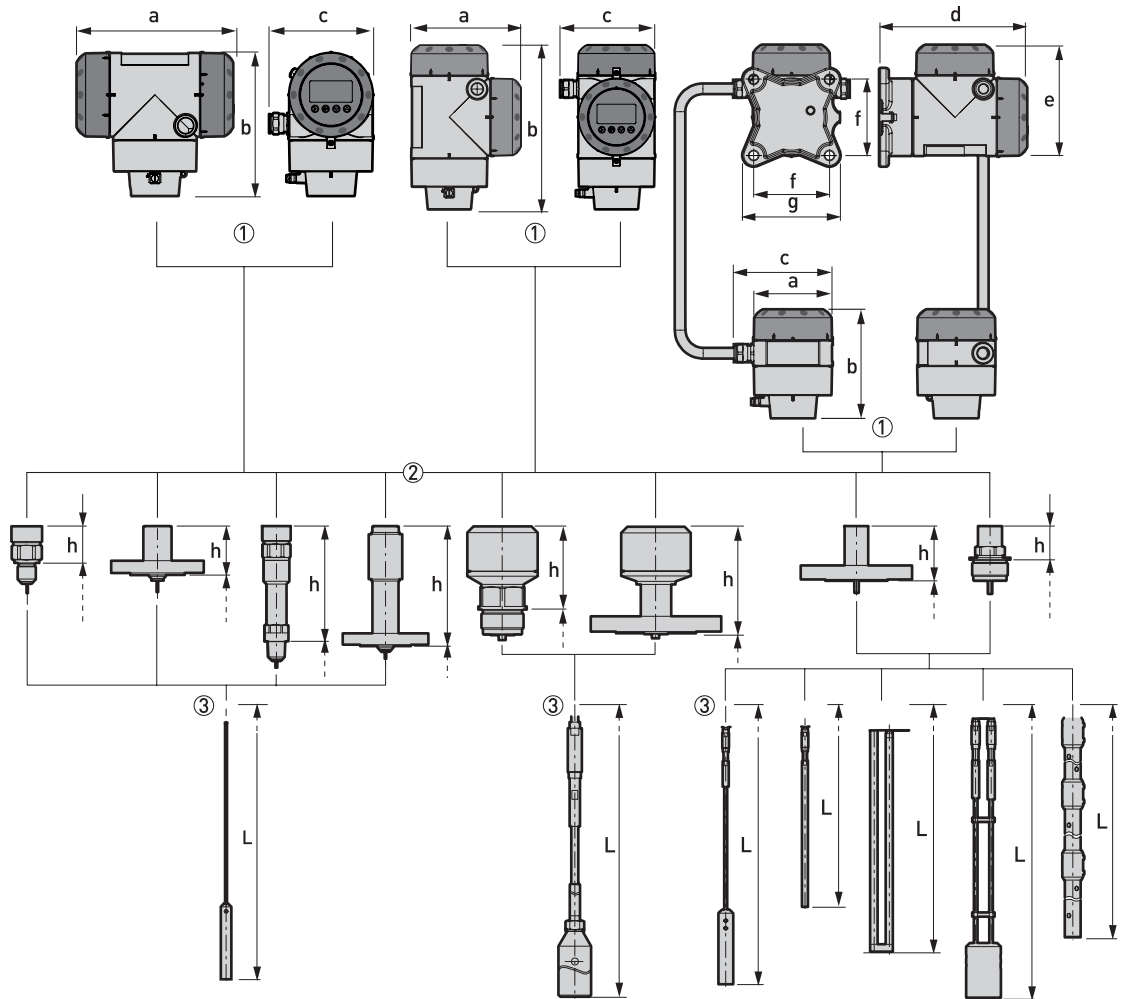

Housing Dimensions

- Housing Option.** From left to right: Compact Converter with Horizontal Housing, Compact Converter with Vertical Housing, and Remote Converter (top) and Probe Housing (bottom)
- Process Connection Options.** From left to right: Threaded Connection for $\text{\O}2$ mm / 0.08" Single Cable Probe, Flange Connection for $\text{\O}2$ mm / 0.08" Single Cable Probe, High-Temperature (HT) Threaded Connection for $\text{\O}2$ mm / 0.08" Single Cable Probe, HT Flange Connection for $\text{\O}2$ mm / 0.08" Single Cable Probe, Threaded Connection for $\text{\O}8$ mm / 0.32" Single Cable Probe, Flange Connection for $\text{\O}8$ mm / 0.32" Single Cable Probe, Flange Connection for other Probes, Threaded Connection for other Probes
- Probe Options.** From left to right: $\text{\O}2$ mm / 0.08" Single Cable Probe, $\text{\O}8$ mm / 0.32" Single Cable Probe, $\text{\O}4$ mm / 0.16" Single Cable Probe, Single Rod (Single-Piece or Segmented) Probe, Double Rod Probe, $\text{\O}4$ mm / 0.16" Double Cable Probe and Coaxial (Single-Piece or Segmented) Probe

BLISSFLEX 2200

Weather Protection Option

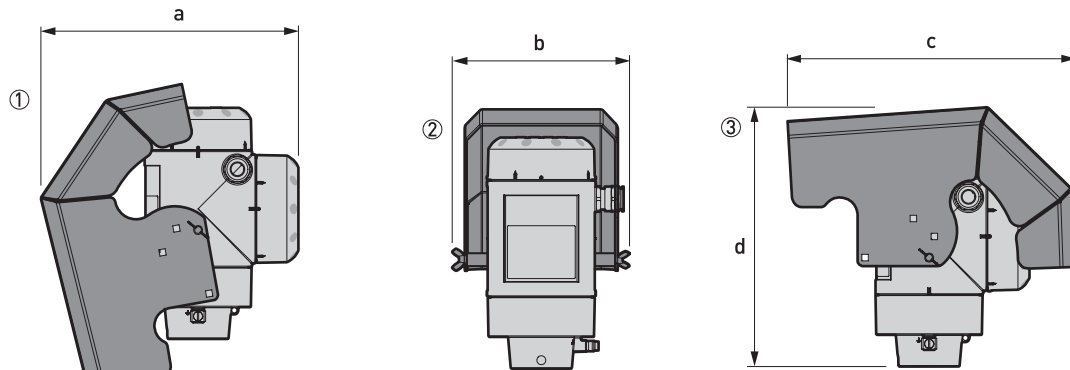

Weather protection option for Compact / Vertical and Remote versions

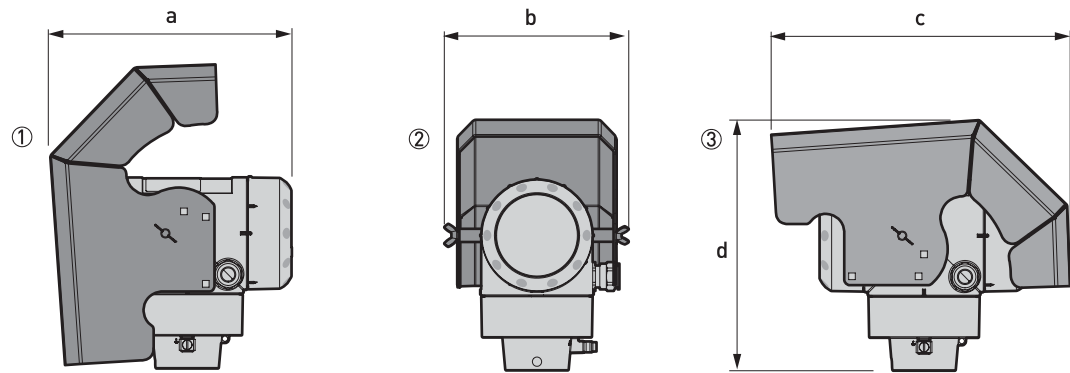

Weather protection option for Compact / Horizontal and Remote versions

1. Left side (with weather protection open)
2. Rear view (with weather protection closed)
3. Right side (with weather protection closed)

Dimensions and Weights in mm and kg

Probe	Dimensions (mm)				Weights (kg)
	a	b	c	d	
Compact / Vertical or Remote versions	244	170	274	245	1.6
Compact / Horizontal or Remote versions	221	170	274	229	1.6

Dimensions and Weights in inches and lb

Probe	Dimensions (inch)				Weights (lb)
	a	b	c	d	
Compact / Vertical or Remote versions	9.6	6.7	10.8	9.6	3.5
Compact / Horizontal or Remote versions	8.7	6.7	10.8	9.0	3.5



RADAR TRANSMITTERS

BLISSFLEX 2200

Single Probes

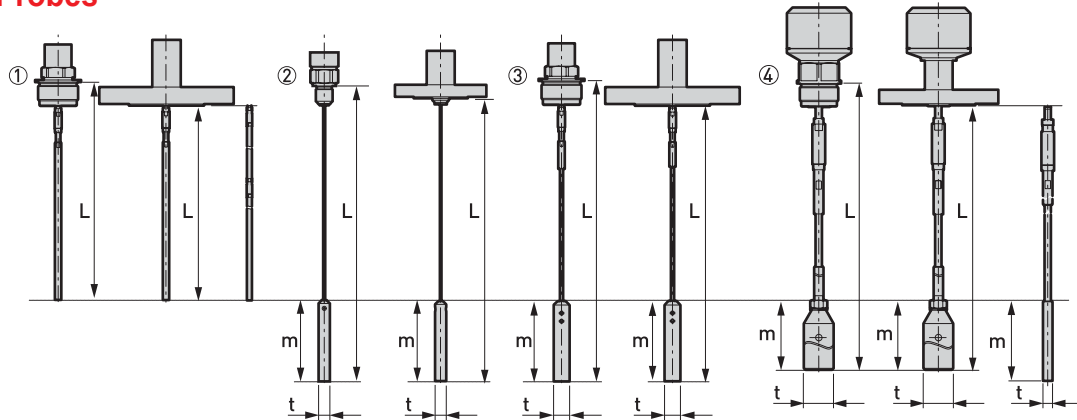

Single Probe Options

1. Single Rod $\varnothing 8$ mm / $\varnothing 0.32$ " (thread and flange versions – the segmented probe option is shown on the right side)
2. Single Cable $\varnothing 2$ mm / $\varnothing 0.08$ " (thread and flange versions)
3. Single Cable $\varnothing 4$ mm / $\varnothing 0.16$ " (thread and flange versions)
4. Single Cable $\varnothing 8$ mm / $\varnothing 0.32$ " (thread and flange versions – an alternative counterweight is shown on the right side)

Probe length, L, includes the length of the counterweight.

A wide range of counterweights and anchoring solutions are available. For dimensional data, refer to the pages that follow. For installation data, refer to the operation & maintenance spelling.

Single Probes: Dimensions in mm

Probe	Dimensions (mm)			
	L min.	L max.	m	t
Single Rod $\varnothing 8$ mm ①	1000 ②	4000	—	—
Single Rod $\varnothing 8$ mm (segmented) ①	1000 ②	6000	—	—
Single Cable $\varnothing 2$ mm	1000 ②	40000	100	$\varnothing 14$
Single Cable $\varnothing 4$ mm	1000 ②	40000	100	$\varnothing 20$
Single Cable $\varnothing 8$ mm, type 1	1000 ②	40000	100	$\varnothing 12$
Single Cable $\varnothing 8$ mm, type 2	1000 ②	40000	245	$\varnothing 38$

Single Probes: Dimensions in inches

Probe	Dimensions (inch)			
	L min.	L max.	m	t
Single Rod $\varnothing 0.32$ " ①	39 ②	158	—	—
Single Rod $\varnothing 0.32$ " (segmented) ①	39 ②	236	—	—
Single Cable $\varnothing 0.08$	39 ②	1575	3.9	$\varnothing 0.6$
Single Cable $\varnothing 0.16$ "	39 ②	1575	3.9	$\varnothing 0.8$
Single Cable $\varnothing 0.32$ ", type 1	39 ②	1575	3.9	$\varnothing 0.5$
Single Cable $\varnothing 0.32$ ", type 2	39 ②	1575	9.6	$\varnothing 1.5$

① A device with this Probe option must be assembled on site. For the assembly procedure, refer to the operation manual or the printed procedure supplied with the components.

② A shorter Probe length is available on request

BLISSFLEX 2200

Double And Coaxial Probes

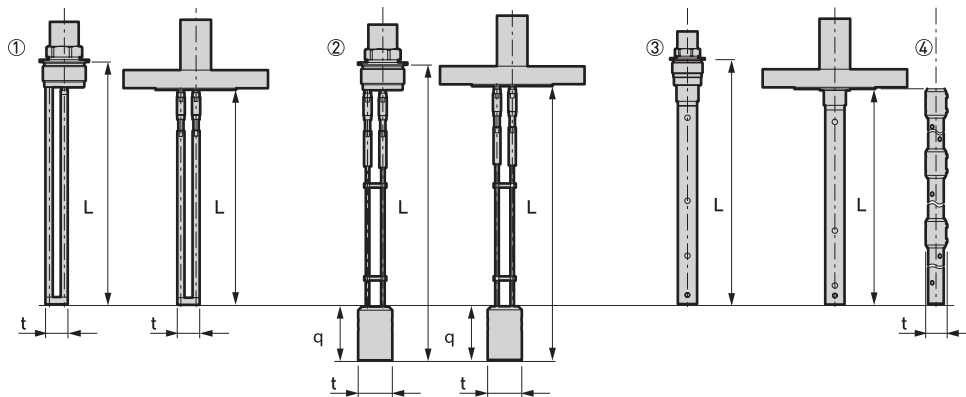

Double and Coaxial Probe Options

1. Double Rod $\text{\O}8$ mm / $\text{\O}0.32$ " (thread and flange versions)
2. Double Cable $\text{\O}4$ mm / $\text{\O}0.16$ " (thread and flange versions)
3. Coaxial $\text{\O}22$ mm / $\text{\O}0.87$ " (thread and flange versions)
4. Coaxial $\text{\O}22$ mm / $\text{\O}0.87$ " (segmented version)

Probe length, L, includes the length of the counterweight.

A wide range of counterweights and anchoring solutions are available. For dimensional data, refer to the pages that follow. For installation data, refer to the handbook.

Double Probes: Dimensions in mm

Probe	Dimensions (mm)			
	L min.	L max.	q	t
Double rod $\text{\O}8$ mm	1000 ①	4000	—	25
Double cable $\text{\O}4$ mm	1000 ①	28000	60	$\text{\O}38$
Coaxial $\text{\O}22$ mm	600 ①	6000	—	—
Coaxial $\text{\O}22$ mm (segmented) ②	600 ①	6000	—	$\text{\O}28$

① A shorter probe length is available on request

② A device with this Probe option must be assembled on site. For the assembly procedure, refer to the handbook or the printed procedure supplied with the components.

Double Probes: Dimensions in mm

Probe	Dimensions (inch)			
	L min.	L max.	q	t
Double rod $\text{\O}0.32$ "	39 ①	158	—	1.0
Double cable $\text{\O}0.16$ "	39 ①	1102	2.4	$\text{\O}1.5$
Coaxial $\text{\O}0.87$ "	24 ①	236	—	—
Coaxial $\text{\O}0.87$ " (segmented) ②	24 ①	236	—	$\text{\O}1.1$

① A shorter probe length is available on request

② A device with this probe option must be assembled on site. For the assembly procedure, refer to the handbook or the printed procedure supplied with the components.



RADAR TRANSMITTERS

BLISSFLEX 2200

Probe End Options for Cable Probes: Single Cable Ø4 mm / 0.16"

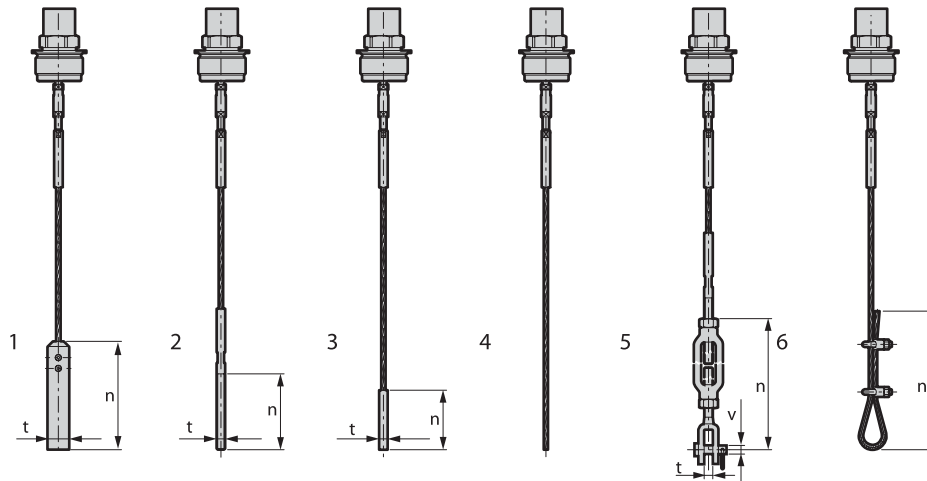

Probe End options for Cable Probes: Single Cable Ø4 mm / 0.16"

1. Standard Counterweight
2. Threaded End
3. Crimped End
4. Open End
5. Turnbuckle
6. Chuck

Double Probes: Dimensions in mm

Probe End Type	Dimensions (mm)		
	n	t	v
Counterweight	100	Ø20	—
Threaded End	70	M8	—
Crimped End	55	Ø8	—
Open End	—	—	—
Turnbuckle	172 ①	11	Ø6
Chuck	300	—	—

① Minimum length

Double Probes: Dimensions in mm

Probe End Type	Dimensions (inch)		
	n	t	v
Counterweight	3.9	Ø0.8	—
Threaded End	2.8	M8	—
Crimped End	2.2	Ø0.3	—
Open End	—	—	—
Turnbuckle	6.8 ①	0.4	Ø0.2
Chuck	11.8	—	—

① Minimum length



BLISSFLEX 2200

Probe End Options for Cable Probes: Single Cable Ø8 mm / 0.32"

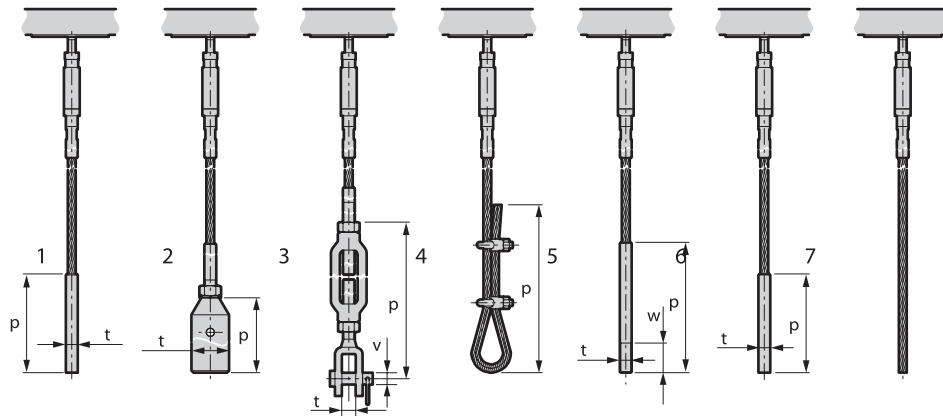

Probe End options for Cable Probes: Single Cable Ø8 mm / 0.32"

1. Standard Counterweight 1
2. Standard Counterweight 2
3. Turnbuckle
4. Chuck
5. Threaded End
6. Crimped End
7. Open End

Double Probes: Dimensions in mm

Probe End Type	Dimensions (mm)			
	p	t	v	w
Counterweight 1	100	Ø12	—	—
Counterweight 2	245	Ø38	—	—
Turnbuckle	293 ①	14	Ø12	—
Chuck	300	—	—	—
Threaded End	132	M12	—	30
Crimped End	100	Ø12	—	—
Open End	—	—	—	—

① Minimum length

Double Probes: Dimensions in mm

Probe End Type	Dimensions (mm)			
	p	t	v	w
Counterweight 1	100	Ø12	—	—
Counterweight 2	245	Ø38	—	—
Turnbuckle	293 ①	14	Ø12	—
Chuck	300	—	—	—
Threaded End	132	M12	—	30
Crimped End	100	Ø12	—	—
Open End	—	—	—	—

① Minimum length



RADAR TRANSMITTERS

BLISSFLEX 2200

Probe End Options for Cable Probes: Double Cable Ø4 mm / 0.16"

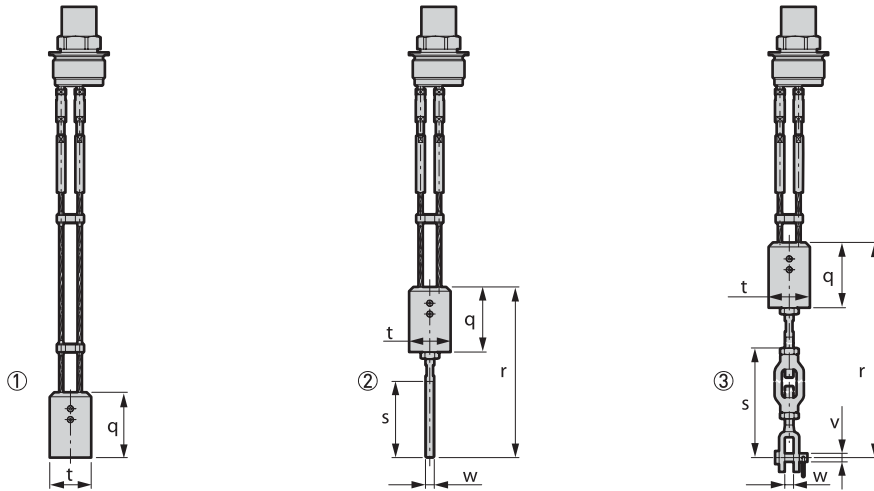

Probe End options for Cable Probes: Double Cable Ø4 mm / 0.16"

1. Standard counterweight
2. Threaded End
3. Turnbuckle

Probes: Dimensions and Weights in mm and kg

Probe	Dimensions (inch)					
	q	r	s	t	v	w
Counterweight	60	—	—	Ø38	—	—
Threaded End	60	157	70	Ø38	—	M8
Turnbuckle	60	289 ±46	172 ①	Ø38	Ø6	11

Probes: Dimensions and Weights in mm and kg

Probe	Dimensions (inch)					
	q	r	s	t	v	w
Counterweight	2.4	—	—	Ø1.5	—	—
Threaded end	2.4	6.2	2.8	Ø1.5	—	M8
Turnbuckle	2.4	11.4 ±1.8	6.8 ①	Ø1.5	Ø0.2	0.4

① Minimum length



BLISSFLEX 2200

Converter and Probe Housing Weights

Type of Housing	Weights			
	Aluminum Housing		Stainless Steel Housing	
	[kg]	[lb]	[kg]	[lb]

Non-Ex / Intrinsically-Safe (Ex i / IS)

Compact	2.8	6.2	6.4	14.1
Remote Converter ①	2.5	5.5	5.9	13.0
Probe Housing ①	1.8	4.0	3.9	8.6

Explosion Proof (Ex d / XP)

Compact	3.2	7.1	7.5	16.5
Remote Converter ①	2.9	6.40	7.1	15.65
Probe Housing ①	1.8	4.0	3.9	8.6

① The remote version of the device has a "Remote Converter" and a "Probe Housing". For more data, refer to "Housing Dimensions" at the start of this section.

Probe Weights

Probes	Min. Process Connection Size		Stainless Steel Housing	
	Thread	Flange	[kg/m]	[lb/ft]
Single Cable Ø2 mm / 0.08"	G ½A; ½ NPTF	DN25 PN40; 1" 150 lb; 1½" 300 lb	0.016 ①	0.035 ①
Single Cable Ø4 mm / 0.16"	G ¾A; ¾ NPT	DN25 PN40; 1" 150 lb; 1½" 300 lb	0.12 ①	0.08 ①
Single Cable Ø8 mm / 0.32"	G 1½A; 1½ NPT	DN40 PN40; 1½" 150 lb; 1½" 300 lb	0.41 ①	0.28 ①
Double Cable Ø4 mm / 0.16"	G 1½A; 1½ NPT	DN50 PN40; 2" 150 lb; 2" 300 lb	0.24 ①	0.16 ①
Single Rod Ø8 mm / 0.32"	G ¾A; ¾ NPT	DN25 PN40; 1" 150 lb; 1½" 300 lb	0.41 ②	0.28 ②
Double Rod Ø8 mm / 0.32"	G 1½A; 1½ NPT	DN50 PN40; 2" 150 lb; 2" 300 lb	0.82 ②	0.56 ②
Coaxial Ø22 mm / 0.87"	G ¾A; ¾ NPT	DN25 PN40; 1" 150 lb; 1½" 300 lb	0.79 ②	0.53 ②

① This value does not include the weights of the counterweight or the flange

② This value does not include the weight of the flange



RADAR TRANSMITTERS

BLISSWAVE 1010

PRODUCT FEATURES AND OVERVIEW

THE FMCW RADAR LEVEL TRANSMITTER FOR BYPASS CHAMBERS

The BLISSWAVE 1010 is a non-contact FMCW radar welded to a bypass chamber with an optional IP66 level indicator (BM series MLG). It continuously measures the distance and level of clean liquids.

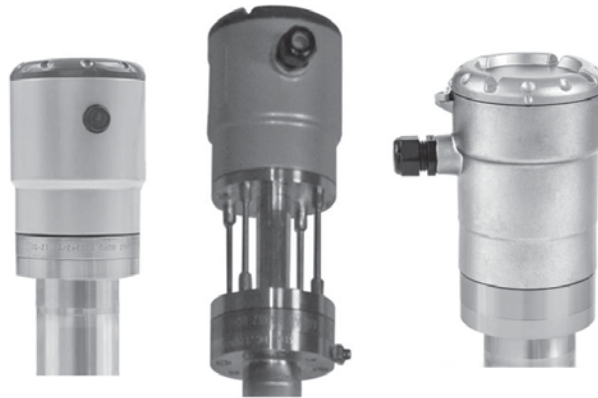

HIGHLIGHTS

- 2-Wire, loop-powered, HART®, 6 GHz Radar (FMCW) Level Transmitter for clean liquids
- Welded to a bypass chamber or BM Series MLI
- Device is configured and ready to use before it leaves the factory
- Adjustments possible using HART® communication / DTM / DDs
- ± 5 mm / 0.2" accuracy
- Measuring distance up to 8 m / 26.2 ft
- Max. process conditions +150°C / +302°F and 40 barg / 580 psig
- No minimum dielectric constant when using a float

BLISSWAVE 1010

OVERVIEW



Standard Aluminum Housing

- Max. process connection temperature:
+100°C / +212°F
- Max. process pressure: 16 barg / 232 psig



Aluminum Housing With Distance Piece

- Max. process connection temperature:
+150°C / +302°F
- Max. process pressure: 40 barg / 580 psig



Stainless Steel Housing

- Max. process connection temperature:
+120°C / +248°F
- Max. process pressure: 40 barg / 580 psig

APPLICATIONS

- Raw Material Storage
- Water Hammer Arresters
- Liquefied Gas
- Hydraulic Oil



RADAR TRANSMITTERS

BLISSWAVE 1010

MEASURING PRINCIPLE

A radar signal is emitted via an antenna, reflected from the product surface and received after a time t . The radar principle used is FMCW (Frequency Modulated Continuous Wave).

The FMCW-radar transmits a high frequency signal whose frequency increases linearly during the measurement phase (called the frequency sweep). The signal is emitted, reflected on the measuring surface and received with a time delay, t . Delay time, $t=2d/c$, where d is the distance to the product surface and c is the speed of light in the gas above the product.

For further signal processing the difference Δf is calculated from the actual transmitted frequency and the received frequency. The difference is directly proportional to the distance. A large frequency difference corresponds to a large distance and vice versa. The frequency difference Δf is transformed via a Fourier transformation (FFT) into a frequency spectrum and then the distance is calculated from the spectrum. The level results from the difference between the maximum distance and the measured distance.

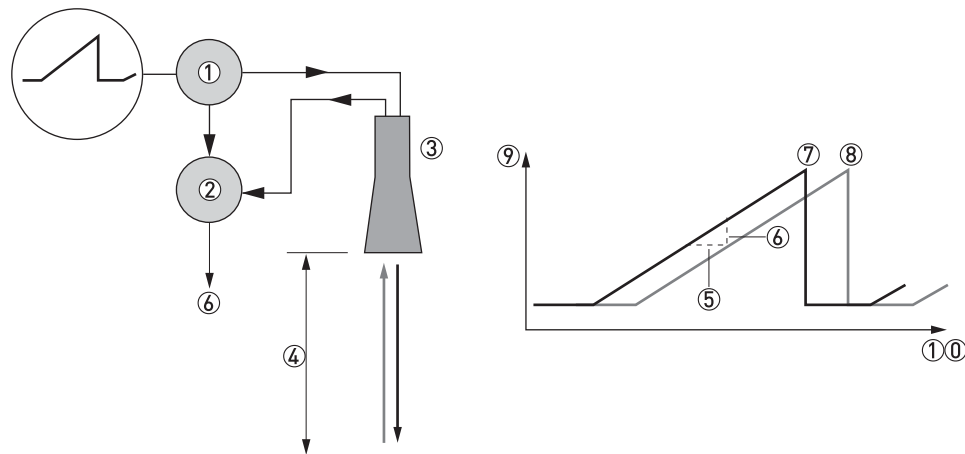

Measuring Principle Of Fmcw Radar

1. Transmitter
2. Mixer
3. Antenna
4. Distance to product surface, where change in frequency is proportional to distance
5. Differential time delay, Δt
6. Differential frequency, Δf
7. Frequency transmitted
8. Frequency received
9. Frequency
10. Time



BLISSWAVE 1010

Technical Data

- The following data is provided for general applications. If you require data that is more relevant to your specific application, please contact us or your local sales office.
- Additional information (certificates, special tools, software,...) and complete product documentation can be provided on request.

MEASURING SYSTEM

Measuring Principle	2-wire loop-powered level transmitter; C-band (6 GHz) FMCW radar
Application Range	Level indication of liquids in applications up to 40 barg / 580 psig
Primary Measured Value	Distance to the surface of the liquid (or the top of the float, if the liquid has a low dielectric constant)
Secondary Measured Value	Level of the liquid in the bypass chamber

DESIGN

Construction	The measurement system consists of a bypass chamber, a signal converter and an optional float
Measuring Range	0.3...5.6 m / 0.98...18.4 ft (max. 8 m / 26.2 ft)
Top Dead Zone	Minimum value: 300 mm / 11.8" from the matching element
User Interface	PACTware™

MEASURING ACCURACY

Repeatability	±2 mm/ ±0.08"
Accuracy	±5 mm/ ±0.2" ①
Influence of temperature on the bypass chamber	0.01 mm/1 m of distance/°C (relative to +25°C) / 0.000216"/1 ft of distance/°F (relative to +77°F)
Reference conditions acc. to DIN EN 61298-1	
Temperature	+18...+30°C / +64...+86°F
Pressure	860...1060 mbara / 12.5...15.4 psia
Relative Air Humidity	45...75%
Target	A special float with a target is installed in the bypass chamber and used to calibrate the device

OPERATING CONDITIONS

Temperature	
Ambient Temperature	-40...+85°C / -40...+185°F Ex: see supplementary operating instructions or approval certificates
Storage Temperature	-40...+85°C / -40...+185°F
Process Temperature	Standard aluminum version with Metapeek process seal: with a Kalrez® 6375 gasket: -20...+100°C / -4...+212°F with a FKM/FPM gasket: -40...+100°C / -40...+212°F with a EPDM gasket: -40...+100°C / -40...+212°F ②
	Aluminum version with distance piece and Metaglas® process seal: with a Kalrez® 6375 gasket: -20...+150°C / -4...+302°F with a FKM/FPM gasket: -40...+150°C / -40...+302°F with a EPDM gasket: -40...+150°C / -40...+302°F ③



RADAR TRANSMITTERS

BLISSWAVE 1010

	Stainless Steel version with Metaglas® Process Seal: with a Kalrez® 6375 gasket: -20...+120°C / -4...+248°F with a FKM/FPM gasket: -40...+120°C / -40...+248°F with a EPDM gasket: -40...+120°C / -40...+248°F ③
	The process connection temperature must agree with the temperature limits of the gasket material. Ex: see supplementary operating instructions or approval certificates
Pressure	
Process Pressure	Standard (with Metapeek): -1...16 barg / -14.5...232 psig
	With Metaglas®: -1...40 barg / -14.5...580 psig
Other Conditions	
Minimum Dielectric Constant (ϵ_r)	Not applicable. If $\epsilon_r < 3$, a float with a target is used.
Ingress Protection	IEC 60529: IP66/67
Maximum Rate of Change	10 m/min / 32.8 ft/min
Measurement Update Rate	Typically 2 measurement cycles/s

INSTALLATION CONDITIONS

Dimensions and Weights	For dimensions and weights data, refer to Dimensions and weights and the technical data sheet for the BM series MLG
------------------------	---

MATERIALS

Housing	Standard: Polyester-Coated Aluminum
	Option: Stainless Steel (1.4408 / 316)
Wetted Materials	Standard: Stainless Steel (1.4404 / 316L) bypass chamber / magnetic level indicator with a PEEK cone in the matching element and a FKM/FPM, EPDM or Kalrez® 6375 O-ring
Process Seal	Standard Aluminum: Metapeek Process Seal with O-ring
	Aluminum version with distance piece: Metaglas® process seal with O-ring
	Stainless Steel Version: Metaglas® process seal with O-ring
Cable Gland	Standard: none
	Options: Plastic (Non-Ex: black, Ex ia-approved: blue); Nickel-Plated Brass; Stainless Steel
Weather Protection (option)	Stainless Steel (1.4404 / 316L)

PROCESS CONNECTIONS

The device is welded to the top of the bypass chamber of the Magnetic Level Indicator. For more data about the Process Connections of the Magnetic Level Indicator, refer to the technical data sheet for the BM series MLG.
--



BLISSWAVE 1010

ELECTRICAL CONNECTIONS

Power Supply	Non-Ex, Ex db- and Ex tb-approved devices 14.5...32 VDC; min./max. value for an output of 22 mA at the terminals Ex ia-approved devices 14.5...30 VDC; min./max. value for an output of 22 mA at the terminals
Maximum Current	22 mA
Current Output Load	$RL [\Omega] \leq ((U_{ext} - 14.5 V) / 22 \text{ mA})$
Cable Entry	Standard: M20×1.5 (F); Option: ½ NPT (F)
Cable Gland	Standard: None Options: M20×1.5 (cable diameter: 6...10 mm / 0.2...0.39"); others are available on request
Cable Entry Capacity (terminal)	0.5...2.5 mm ²

INPUT AND OUTPUT

Current Output / HART®	
Output Signal	4...20 mA HART® or 3.8...20.5 mA acc. to NAMUR NE 43 ④
Resolution	±3 µA
Analog Temperature Drift	Typically 50 ppm/K (150 ppm/K maximum)
Digital Temperature Drift	Typically ±5 mm / 0.2" – max. 15 mm / 0.59" for the full temperature range
Error Signal	High: 22 mA; Low: 3.6 mA acc. to NAMUR NE 43

APPROVALS AND CERTIFICATION

Explosion Protection	II 1/2 G Ex ia IIC Tx Ga/Gb; ⑤
	II 2 D Ex ia IIIC T120°C Db (Stainless Steel Housing only);
	II 1/2 G Ex db IIC T6...T4 Ga/Gb (Stainless Steel Housing only);
	II 2 D Ex tb IIIC T120°C Db (Stainless Steel Housing only)
ATEX (Ex ia or Ex db or Ex tb) KIWA 15ATEX0022 X	Ex ia IIC Tx Ga/Gb; ⑤
	Ex ia IIIC T120°C Db (Stainless Steel Housing only);
	Ex db IIC T6...T4 Ga/Gb (Stainless Steel Housing only);
	Ex tb IIIC T120°C Db (Stainless Steel Housing only)
Construction Code	Option: NACE MR0175 / ISO 15156; NACE MR0103

- ① For more data, refer to the "Measuring Accuracy" section in this chapter
- ② Kalrez® is a registered trademark of DuPont Performance Elastomers L.L.C. The process connection temperature must agree with the temperature limits of the gasket material.
- ③ Metaglas® is a registered trademark of Herberts Industrieglas, GMBH & Co., KG. The process connection temperature must agree with the temperature limits of the gasket material.
- ④ HART® is a registered trademark of the HART Communication Foundation
- ⑤ Tx = T6...T4 (without a distance piece) or T6...T3 (with a distance piece)



RADAR TRANSMITTERS

BLISSWAVE 1010

DIMENSIONS AND WEIGHTS

Device Versions

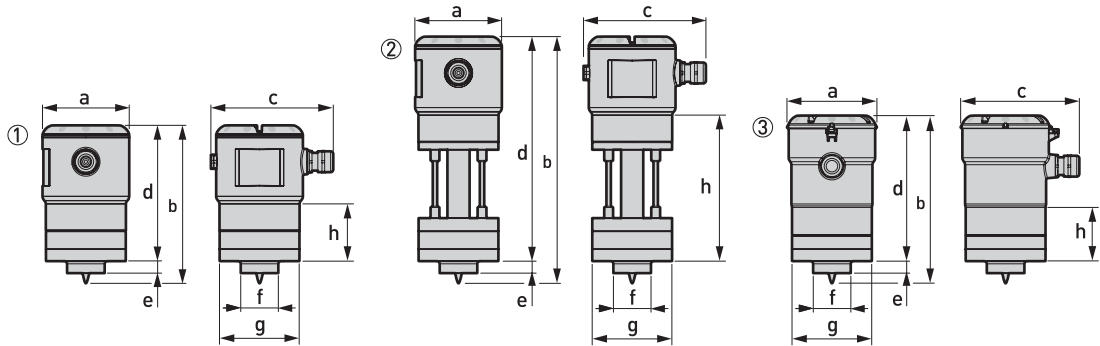

Device Versions

- 1 Non-Ex or Ex ia-approved device (aluminum housing – standard version)
- 2 Non-Ex or Ex ia-approved device (aluminum housing – with distance piece)
- 3 Non-Ex, Ex ia- Ex db- or Ex tb-approved device (stainless steel housing)

Device Versions: Dimensions in mm and inches

Dimensions	Device Versions					
	Aluminum: Non-Ex or Ex ia-approved (standard)		Aluminum: Non-Ex or Ex ia-approved (with distance piece)		Stainless Steel: Non-Ex, Ex ia, Ex db or Ex tb-approved	
	[mm]	[inches]	[mm]	[inches]	[mm]	[inches]
a	98	3.86	98	3.86	99.5	3.92
b	178	7.01	278	10.94	189	7.44
c	138	5.43	138	5.43	133	5.24
d	153	6.02	253	9.96	164	6.46
e	14	0.55	14	0.55	14	0.55
f	42.4	1.67	42.4	1.67	42.4	1.67
g	90	3.54	90	3.54	90	3.54
h	64.5	2.54	164	6.47	60	2.36

BLISSWAVE 1010

Weather Protection

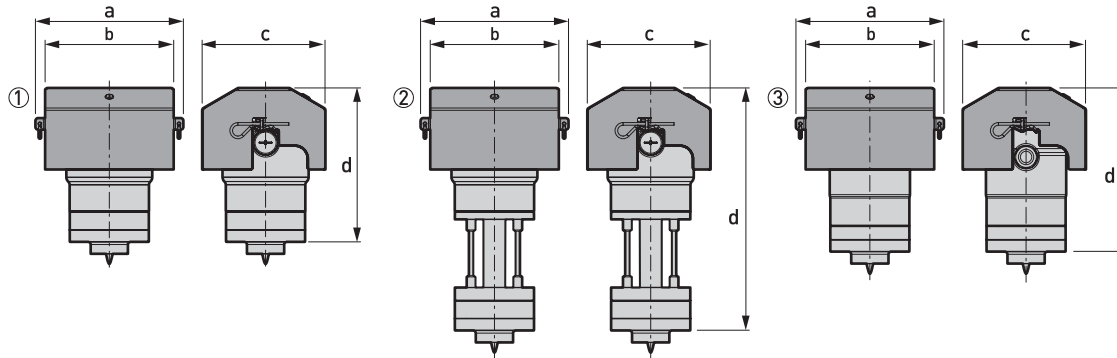

Device versions with the weather protection option

1. Non-Ex or Ex ia-approved device (aluminum housing – standard version)
2. Non-Ex or Ex ia-approved device (aluminum housing – with distance piece)
3. Non-Ex, Ex ia- Ex db- or Ex tb-approved device (stainless steel housing)

Devices with Weather Protection: Dimensions in mm and inches

Dimensions	Devices with Weather Protection					
	Aluminum: Non-Ex or Ex ia-approved (standard)		Aluminum: Non-Ex or Ex ia-approved (with distance piece)		Stainless Steel: Non-Ex, Ex ia, Ex db or Ex tb-approved	
	[mm]	[inches]	[mm]	[inches]	[mm]	[inches]
a	168	6.61	168	6.61	168	6.61
b	146	5.75	146	5.75	146	5.75
c	140	5.51	140	5.51	140	5.51
d	173.5	6.83	273.5	10.77	184.5	7.26

Devices with Weather Protection: Dimensions in mm and inches

Dimensions	Weights							
	Aluminum				Stainless Steel			
	without weather protection		with weather protection		without weather protection		with weather protection	
	[kg]	[lb]	[kg]	[lb]	[kg]	[lb]	[kg]	[lb]

Non-Ex / intrinsically-safe (Ex ia)

Standard	2.54	5.61	3.34	7.36	—	—	—	—
With distance piece	3.52	7.76	4.32	9.52	—	—	—	—

Non-Ex / intrinsically-safe (Ex ia)

Standard	—	—	—	—	3.85	8.49	4.65	10.25
----------	---	---	---	---	------	------	------	-------



RADAR TRANSMITTERS

BLISSWAVE 5200

PRODUCT FEATURES AND OVERVIEW

THE LOW-COST FMCW LEVEL RADAR

This device is a non-contact radar level meter that uses FMCW technology. It measures distance, level and volume of liquids and pastes. It is ideal for measuring the level of corrosive products with its PP or PTFE antenna options.



1. PP or PTFE Wave Horn antennas for the measurement of corrosive products
2. Optional remote converter can be installed up to 100 m / 328 ft away from the antenna
3. Wall support
4. Horizontal / vertical housings and antenna options makes the device suitable for many applications and for installation in a variety of positions
5. Aluminum or stainless steel housing
6. 2-wire level meter
7. Optional LCD display with 4-button keypad
8. Converter is rotatable 360° and removable under process conditions
9. Dual process seal system



BLISSWAVE 5200

OPTIONAL INTEGRATED DISPLAY

The display can be ordered with the device or as an accessory. It shows measurement data on a 128 × 64 pixel screen. The configuration menu permits the device to be set up in a small number of intuitive steps. 9 languages are available.

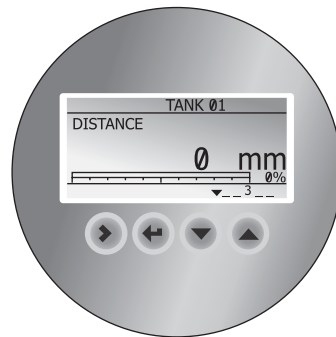

HIGHLIGHTS

- PP or PTFE Wave Horn antennas for the measurement of corrosive products
- Modular design: horizontal or vertical position of housing is suitable for almost all installations
- Optional local display with an integrated 4-button keypad. It is not necessary to remove the housing cover to get access to the keypad.
- Quick coupling system permits removal of the housing under process conditions and rotation of the housing through 360°
- Bayonet housing cover permits easy opening and closing of the housing, even after years in service
- Measuring range up to 30 m / 98.4 ft
- SIL2-compliant according to IEC 61508 for safety-related systems
- Each device is calibrated on dedicated calibration rigs before it leaves the factory

APPLICATIONS

- Storage Tanks
- Process Tanks
- Open Channel Flow (if PACTware™ software tool is used)
- River Level



RADAR TRANSMITTERS

BLISSWAVE 5200

OVERVIEW

BLISSWAVE 5200 C - Compact / Vertical Version



- The converter is vertical. It is attached directly to the process connection (compact version).
- For installation of the device on the ground or in a recess.
- The optional LCD display is attached to the top or the side of the device.

BLISSWAVE 5200 C - Compact / Vertical Version



BLISSWAVE 5200 C - Compact / Horizontal Version



- The converter is horizontal. It is attached directly to the process connection (compact version).
- This version is ideal for installation in areas with low roof clearances.
- For locations where it is easier to read data on the optional LCD display if the converter is in a horizontal position.

- Users can read measurements and configure the device from the bottom of the tank.
- The remote converter can be installed up to 100 m / 328 ft away from the process connection on the tank.
- Attach the remote converter to a wall, pipe or rigid surface with the supplied wall support.

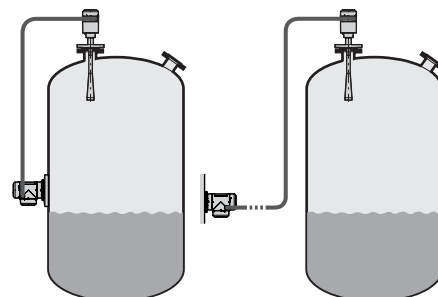

BLISSWAVE 5200

WEATHER PROTECTION

A weather protection option can also be ordered with the device. It is recommended for outdoor applications.

- Must be ordered with the device.
- Can be ordered for both compact versions of the device and the antenna housing of the remote version.
- Easily opened and closed.

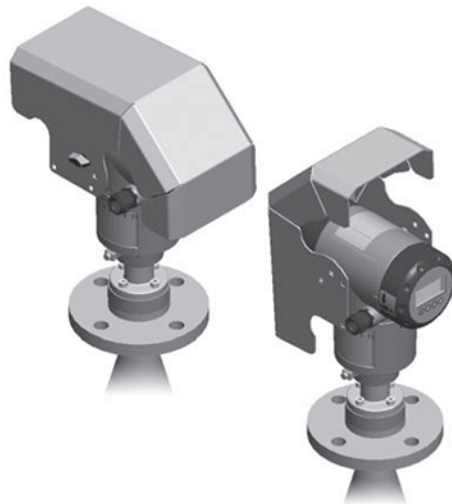



RADAR TRANSMITTERS

BLISSWAVE 5200

APPLICATIONS

1. Level Measurement of Liquids

The level meter can measure the level of a wide range of liquid products on a large variety of installations within the stated pressure and temperature range. It does not require any alibration: it is only necessary to do a short configuration procedure.

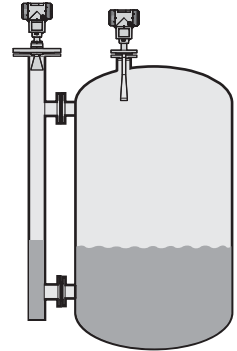

2. Volume (mass) Measurement

A strapping table function is available in the configuration menu for volume or mass measurement. Up to 30 volume (mass) values can be related to level values. For example:

Level 1= 2 m / Volume 1= e.g. 0.7 m³

Level 2= 10 m / Volume 2= e.g. 5 m³

Level 3= 20 m / Volume 3= e.g. 17 m³

This data permits the device to calculate (by linear interpolation) volume or mass between strapping table entries.

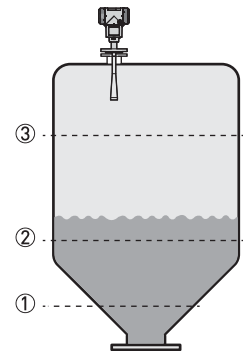

3. Flow Rate Measurement

Flow rate measurement is available for field devices that are used with PACTware™ software. A flow rate conversion function is in the DTM supplied with the device. Make a selection from 6 flow profiles:

Parshall (ISO 9826), Venturi Rectangular (ISO 4359), Venturi Trapezoidal (ISO 4359), Venturi U (ISO 4359), V-Notch (ISO 1438) or Rectangular Notch (ISO 1438).





BLISSWAVE 5200

ANTENNA SELECTION

The graphs below show which antenna to select for the application based on:

- D, the measuring range,
- ϵ_r , is the dielectric constant of the product being measured

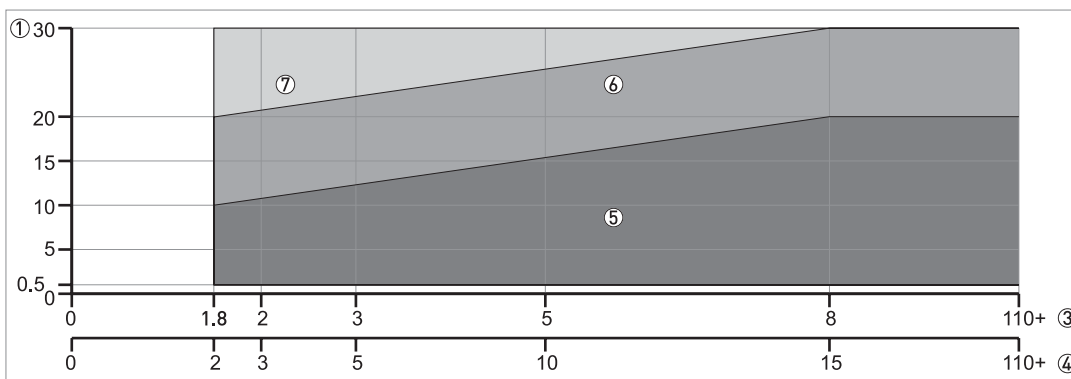
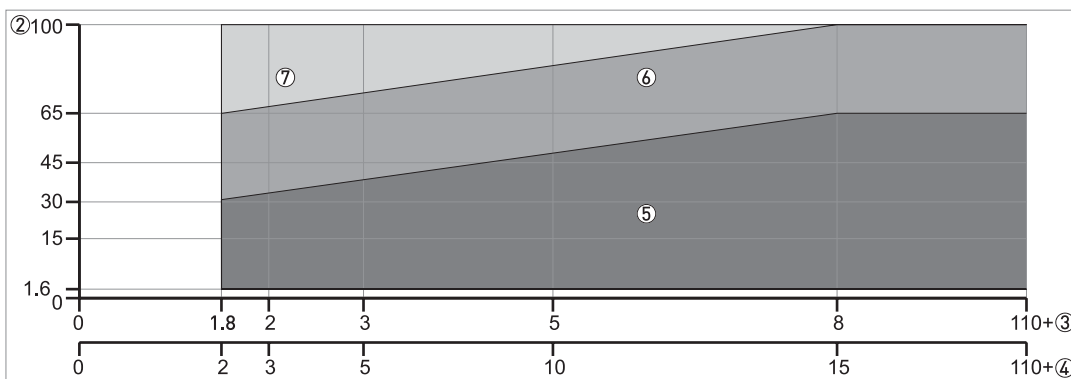

Figure 1-1: Selection of antenna (graph of distance in m against ϵ_r)



- ① Tank height / Measuring range [m]
- ② Tank height / Measuring range [ft]
- ③ ϵ_r for storage tanks with smooth product surface
- ④ ϵ_r for process tanks without agitator or foam
- ⑤ All antennas:
 - DN80/3" and DN100/4" Metallic Horn antenna: only for use in a stilling well*
 - Wave Guide antenna: maximum measuring range is 6 m / 19.68 ft
- ⑥ DN150/6" or DN200/8" Metallic Horn antennas in a stilling well* or DN200/8" Metallic Horn antenna
- ⑦ DN200/8" Metallic Horn antenna in a stilling well*

* A stilling well is equivalent to the Wave Guide antenna option or a bypass chamber



RADAR TRANSMITTERS

BLISSWAVE 5200

MEASURING PRINCIPLE

A radar signal is emitted via an antenna, reflected from the product surface and received after a time t . The radar principle used is FMCW (Frequency Modulated Continuous Wave). The FMCW-radar transmits a high frequency signal whose frequency increases linearly during the measurement phase (called the frequency sweep). The signal is emitted, reflected on the measuring surface and received with a time delay, t . Delay time, $t=2d/c$, where d is the distance to the product surface and c is the speed of light in the gas above the product.

For further signal processing the difference Δf is calculated from the actual transmitted frequency and the received frequency. The difference is directly proportional to the distance. A large frequency difference corresponds to a large distance and viceversa. The frequency difference Δf is transformed via a Fourier transformation (FFT) into a frequency spectrum and then the distance is calculated from the spectrum. The level results from the difference between tank height and measuring distance.

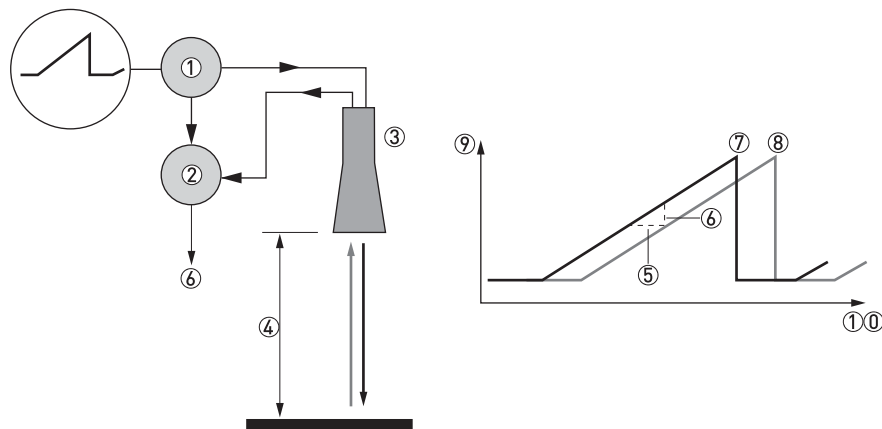

Measuring principle of FMCW radar

1. Transmitter
2. Mixer
3. Antenna
4. Distance to product surface, where change in frequency is proportional to distance
5. Differential time delay, Δt
6. Differential frequency, Δf
7. Frequency transmitted
8. Frequency received
9. Frequency
10. Time



BLISSWAVE 5200

Measurement Modes

"Direct" Mode

If the dielectric constant of the liquid is high ($\epsilon_r \geq 1.8$), the level signal is a reflection on the surface of the liquid.

"TBF Partial" Mode

If the dielectric constant of the liquid is low ($\epsilon_r \leq 1.8$, for long distance measurement), you must use "TBF Partial" mode to measure level correctly. "TBF Partial" is an automatic mode that lets the device make a selection between "Direct Mode" and "TBF" mode. If the device finds a large radar reflection above the "Tank Bottom Area" (the bottom 20% of the tank height), the device will use "Direct" mode. If the device finds a large radar reflection in the "tank bottom area", the device uses TBF mode. This mode can be used only in tanks with flat bottoms.

"Full TBF" Mode

TBF = Tank Bottom Following. If the dielectric constant of the liquid is very low ($\epsilon_r < 1.8$), you must use "Full TBF" mode to measure level correctly. The device uses the radar reflection on the bottom of the tank (the signal goes through the liquid). This mode can be used only in tanks with flat bottoms.

"Full TBF" And "TBF Partial" Modes

It is important to enter the correct dielectric constant value in menu item 2.5.3 Er Product. If not, the device will not measure level accurately.



RADAR TRANSMITTERS

BLISSWAVE 5200

TECHNICAL DATA

- The following data is provided for general applications. If you require data that is more relevant to your specific application, please contact us or your local sales office.
- Additional information (certificates, special tools, software,...) and complete product documentation can be provided on request.

MEASURING SYSTEM

Measuring Principle	2-wire loop-powered level transmitter; X-band (10 GHz) FMCW radar
Application Range	Level measurement of liquids, pastes and slurries
Primary Measured Value	Distance and Reflection
Secondary Measured Value	Level, Volume, Mass and Flow Rate

DESIGN

Construction	The measurement system consists of a measuring sensor (Antenna) and a signal converter
Options	Integrated LCD display (-20..+60°C / -4...+140°F); if the ambient temperature is not in these limits, the display switches off automatically
	High-temperature (HT) extension (if the Process Connection Temperature is more than +150°C / +302°F - Metallic Horn Antenna only)
	Straight Antenna Extensions Max. extension length, PTFE Wave Horn Antenna: 300 mm / 11.8"; Max. extension length, Metallic Horn Antenna: 1000 mm / 39.4"
	"S" Antenna Extension - only for DN150/6" and DN200/8" Metallic Horn Antenna options
	"L" (right angle) Antenna Extension - only for DN150/6" and DN200/8" Metallic Horn Antenna options
	Antenna Purging System - only for DN150/6" and DN200/8" Metallic Horn Antenna options
	Heating / Cooling System (with or without the Antenna Purging System) - only for DN150/6" and DN200/8" Metallic Horn Antenna options
	Signal cable for remote housing version (refer to cable properties in "Electrical Connection: Remote Device Version")
Weather Protection - for the compact version or the Antenna Housing (remote version). It cannot be ordered after delivery of the device.	



BLISSWAVE 5200

Max. Measuring Range	PTFE and PP Wave Horn Antennas: 20 m / 65.6 ft
	DN80 / DN100 Metallic Horn Antennas (installation only in stilling wells): 10 m / 32.8 ft
	DN150 / DN200 Metallic Horn Antennas: 30 m / 98.4 ft
	Wave Guide Antenna: 6 m / 19.7 ft
	Also depends on the dielectric constant of the product and the installation type. Refer also to "Antenna Selection".
Min. Tank Height	1 m / 3.3 ft
Top Dead Zone	Minimum value: Antenna length + Antennna Extension length + 100 mm / 3.9"
Beam Angle (½ angle) of Antenna	PP Wave Horn: 10°
	PTFE Wave Horn: 10°
	Metallic Horn DN80 / 3": 16° - used only in stilling wells
	Metallic Horn DN100 / 4": 12° - used only in stilling wells
	Metallic Horn DN150 / 6": 8°
	Metallic Horn DN200 / 8": 6°
	Wave Guide / Stilling Well: n/a - the radar signal is inside the tube.
Display and User Interface	
Display	LCD display
	128 × 64 pixels in 8-step greyscale with 4-button keypad
Interface Languages	3 language pack options (the language is given in the customer order):
	1 English, French German and Italian
	2 English, French, Spanish and Portuguese
	3 English, Chinese (Mandarin), Japanese and Russian

MEASURING ACCURACY

Resolution	1 mm / 0.04"
Repeatability	±1 mm / ±0.04"
Accuracy	Standard: ±10 mm / ±0.4", when distance < 10 m / 33 ft; ±0.1% of measured distance, when distance > 10 m / 33 ft Option: ±5 mm / ±0.2", when distance < 10 m / 33 ft; ±0.05% of measured distance, when distance > 10 m / 33 ft
Reference conditions acc. to EN 61298-1	
Temperature	+15...+25°C / +59...+77°F
Pressure	1013 mbara ±50 mbar / 14.69 psia ±0.73 psi
Relative Air Humidity	60% ±15%
Target	Metal plate in an anechoic chamber



RADAR TRANSMITTERS

BLISSWAVE 5200

OPERATING CONDITIONS

Temperature	
Ambient Temperature	-40...+80°C / -40...+176°F Ex: see supplementary operating instructions or approval certificates
Storage Temperature	-50...+85°C / -58...+185°F
Process Connection Temperature (higher temperature on request)	PP Wave Horn Antenna: -20...+100°C / -4...+212°F
	PTFE Wave Horn Antenna: -50...+150°C / -58...+302°F
	Metallic Horn Antenna / Wave Guide Antenna: Standard: FKM/FPM (-40...+150°C (+200°C with an HT extension) / -40...+302°F (+392°F with an HT extension)); Options: Kalrez® 6375 (-20...+150°C (+250°C with an HT extension) / -4...+302°F (+482°F with an HT extension)); PFA (-60°C...+130°C / -76...+266°F); EPDM (-50...+130°C / -58...+266°F) The process connection temperature must agree with the temperature limits of the gasket material. Ex: see supplementary operating instructions or approval certificates 1
Pressure	
Process Pressure	PP Wave Horn Antenna: -1...16 barg / -14.5...232 psig. For more data, refer to Pressure Ratings. PTFE Wave Horn Antenna: -1...40 barg / -14.5...580 psig. For more data, refer to Pressure Ratings. Metallic Horn Antenna / Wave Guide Antenna: Standard: -1...40 barg / -14.5...580 psig; Subject to the Process Connection used and the Flange temperature. Higher Pressure on request.
Purging System (option) Max.	6 barg / 87 psig (Higher Pressure on request)
Heating / Cooling System (option)	Max. 6 barg / 87 psig (Higher Pressure on request)
Other Conditions	
Dielectric Constant (ϵ_r)	Direct mode: ≥ 1.8 TBF mode: ≥ 1.1 Refer also to "Technical Data: Antenna Selection".
Ingress Protection	IEC 60529: IP 66/67 NEMA 250: NEMA type 4X (Housing) and type 6P (Antenna)
Maximum Rate of Change	10 m/min / 32.8 ft/min

INSTALLATION CONDITIONS

Process Connection Size	The nominal diameter (DN) should be equal to or larger than the Antenna diameter.
Process Connection Position	Make sure that there are not any obstructions directly below the Process Connection for the device.
Dimensions and Weights	For dimensions and weights data, refer to Dimensions and Weights.



BLISSWAVE 5200

MATERIALS

Housing Standard:	Polyester-Coated Aluminum
	Option: Stainless Steel (1.4404 / 316L)
Antenna Options / Wetted Materials	PTFE Wave Horn Antenna with a PTFE flange cladding
	PP Wave Horn Antenna with a PP jacket/ Threaded Process Connection
	Stainless Steel (1.4404 / 316L) Metallic Horn Antenna with a PTFE process seal and an FKM/FPM, EPDM, Kalrez® 6375 or PFA O-ring gasket
	Stainless Steel (1.4404 / 316L) Wave Guide antennas with a PTFE process seal and an FKM/FPM, EPDM, Kalrez® 6375 or PFA O-ring gasket
Feedthrough	PP Wave Horn Antenna: this is a single-piece antenna (the feedthrough is filled with PP) PTFE Wave Horn Antenna: this is a single-piece antenna (the feedthrough is filled with PTFE)
	Metallic Horn and Wave Guide Antennas: Dual process seal system - 1st seal: PTFE with O-ring gasket , 2nd seal: Metaglas® with O-ring gasket ②
Cable Gland	Standard: none
	Options: Plastic (Non-Ex: black, Ex i-approved: blue); Nickel-plated brass; Stainless Steel
Weather Protection (Option)	Stainless Steel (1.4404 / 316L)

PROCESS CONNECTIONS

Thread	PP Wave Horn Antenna: G 1½; ½ NPT
Flange Version	
EN	PTFE Wave Horn Antenna: DN50...150 in PN16, PN40
	Metallic Horn and Wave Guide Antennas: DN80...200 in PN16, PN40; others on request
ASME	PTFE Wave Horn Antenna: 2"...6" in 150 lb / 300 lb
	Metallic Horn and Wave Guide Antennas: 3"...8" in 150 lb / 300 lb; others on request
JIS	PTFE Wave Horn Antenna: 50...150A in 10K
	Metallic Horn and Wave Guide Antennas: 80...200A in 10K; others on request
Other	Others on request

ELECTRICAL CONNECTIONS

Power Supply	Terminals output - Non-Ex / Ex i: 12...30 VDC; min./max. value for an output of 22 mA at the terminal
	Terminals output - Ex d: 16...36 VDC; min./max. value for an output of 22 mA at the terminal
Maximum Current	22 mA
Current Output Load	Non-Ex / Ex i: $RL [Ω] ≤ ((U_{ext} - 12 V)/22 mA)$.
	Ex d: $RL [Ω] ≤ ((U_{ext} - 16 V)/22 mA)$.
Cable Entry	Standard: M20×1.5 (F); Option: ½ NPT (F)
Cable Gland	Standard: none Options: M20×1.5 (cable diameter: 6...10 mm / 0.2...0.39"); others are available on request
Cable Entry Capacity (terminal)	0.5...2.5 mm ²



RADAR TRANSMITTERS

BLISSWAVE 5200

INPUT AND OUTPUT

Current Output / HART®	
Output Signal	4...20 mA HART® or 3.8...20.5 mA acc. to NAMUR NE 43 ③
Resolution	±3 µA
Temperature Drift	Typically 50 ppm/K
Digital temperature Drift	Max. ±15 mm / 0.6" for the full temperature range
Error Signal	High: 22 mA; Low: 3.6 mA acc. to NAMUR NE 43 ④
PROFIBUS PA	
Type	PROFIBUS MDP interface that agrees with IEC 61158-2 with 31.25 kbit/s; voltage mode (MDP = Manchester Coded Bus Powered)
Function Blocks	1 × Physical Block, 1 × Level Transducer Block, 4 × Analog Input Function Blocks
Device Power Supply	9...32 VDC - bus powered; no additional power supply required
Polarity Sensitivity	No
Basic Current	15 mA
FOUNDATION™ fieldbus	
Physical Layer	FOUNDATION™ fieldbus protocol that agrees with IEC 61158-2 and FISCO model
Communication Standard	H1
ITK Version	6.1
Function Blocks	1 × Resource Block (RB), 3 × Transducer Blocks (TB), 3 × Analog Input Blocks (AI), 1 × Proportional Integral Derivative Block (PID)
	Analog Input Block: 30 ms
	Proportional Integral Derivative Block: 40 ms
Device Power Supply	Not intrinsically safe: 9...32 VDC
	Intrinsically safe: 9...24 VDC
Basic Current	14 mA
Maximum Error Current	20.5 mA (= basic current + error current = 14 mA + 6.5 mA)
Polarity Sensitivity	No
Minimum Cycle Time	250 ms
Output Data	Level, Distance, Ullage Conversion, Level Conversion
Input Data	None
Error Current FDE	Typically 0 mA (FDE =Fault Disconnection Electronic)
Link Master Function	Supported



BLISSWAVE 5200

APPROVALS AND CERTIFICATION

Explosion Protection	
ATEX (Ex ia or Ex d) DEKRA 11ATEX0166 X	Compact Version
	II 1/2 G, 2 G Ex ia IIC T6...T2 Ga/Gb or Ex ia IIC T6...T2 Gb;
	II 1/2 D, 2 D Ex ia IIIC T90°C Da/Db or Ex ia IIIC T90°C Db IP6X;
	II 1/2 G, 2 G Ex d ia IIC T6...T2 Ga/Gb or Ex d ia IIC T6...T2 Gb;
	II 1/2 D, 2 D Ex ia tb IIIC T90°C Da/Db or Ex ia tb IIIC T90°C Db IP6X
	Remote Version, Transmitter
	II 2 G Ex ia [ia Ga] IIC T6...T4 Gb;
	II 2 D Ex ia [ia Da] IIIC T90°C Db;
	II 2 G Ex d ia [ia Ga] IIC T6...T4 Gb;
	II 2 D Ex ia tb [ia Da] IIIC T90°C Db
	Remote Version, Sensor
	II 1/2 G Ex ia IIC T6...T2 Ga/Gb
	II 1/2 D Ex ia IIIC T90°C Da/Db
	II 1/2 G Ex ia IIC T6...T2 Gb
II 1/2 D Ex ia IIIC T90°C Db	
ATEX (Ex ic) DEKRA 13ATEX0051 X	Compact Version
	II 3 G Ex ic IIC T6...T2 Gc;
	II 3 D Ex ic IIIC T90°C Dc
	Remote Version, Transmitter
	II 3 G Ex ic [ic] IIC T6...T4 Gc;
	II 3 D Ex ic [ic] IIIC T90°C Dc
	Remote Version, Sensor
	II 3 G Ex ic IIC T6...T2 Gc;
II 3 D Ex ic IIIC T90°C Dc	
IECEX IECEX DEK 11.0060 X	Compact Version
	Ex ia IIC T6...T2 Ga/Gb or Ex ia IIC T6...T2 Gb or Ex ic IIC T6...T2 Gc;
	Ex ia IIIC T90°C Da/Db or Ex ia IIIC T90°C Db or Ex ic IIIC T90°C Dc;
	Ex d ia IIC T6...T2 or Ex d ia IIIC T6...T2 Gb;
	Ex ia tb IIIC T90°C Da/Db or Ex ia tb IIIC T90°C Db
	Remote Version, Transmitter
	Ex ia [ia Ga] IIC T6...T4 Gb or Ex ic IIC T6...T4 Gc;
	Ex ia [ia Da] IIIC T90°C Db or Ex ic [ic] IIIC T90°C Dc;
	Ex d ia [ia Ga] IIC T6...T4 Gb;
	Ex ia tb [ia Da] IIIC T90°C Db
	Remote Version, Sensor
	Ex ia IIC T6...T2 Ga/Gb or Ex ia IIC T6...T2 Gb or Ex ic IIC T6...T2 Gc;
	Ex ia IIIC T90°C Da/Db or Ex ia IIIC T90°C Db or Ex ic IIIC T90°C Dc
	cFMus - Dual Seal-approved - for 4...20 mA HART output (pending for fieldbus options)
XP-AIS / Cl. I / Div. 1 / Gr. ABCD / T6-T1;	
DIP / Cl. II, III / Div. 1 / Gr. EFG / T6-T1;	
IS / Cl. I, II, III / Div. 1 / Gr. ABCDEFG / T6-T1;	



RADAR TRANSMITTERS

BLISSWAVE 5200

	NI / Cl. I / Div. 2 / Gr. ABCD / T6-T1 NEC 505 (Zone ratings) Cl. I / Zone 0 / AEx d [ia] / IIC / T6-T1; Cl. I / Zone 0 / AEx ia / IIC / T6-T1; Cl. I / Zone 2 / AEx nA / IIC / T6-T1; Zone 20 / AEx ia / IIIC / T90°C Zone 20 / AEx tb [ia] / IIIC / T90°C Hazardous (Classified) Locations, indoor/outdoor Type 4X and 6P, IP66, Dual Seal CEC Section 18 (Zone ratings) Cl. I, Zone 0, Ex d [ia], IIC, T6-T1; Cl. I, Zone 0, Ex ia, IIC, T6-T1; Cl. I, Zone 2, Ex nA, IIC, T6-T1 CEC Section 18 and Annex J (Division ratings) XP-AIS / Cl. I / Div. 1 / Gr. BCD / T6-T1 DIP / Cl. II, III / Div. 1 / Gr. EFG / T6-T1 IS / Cl. I / Div. 1 / Gr. BCD / T6-T1 NI / Cl. I / Div. 2 / Gr. ABCD / T6-T1
Other Standards and Approvals SIL - only for 4...20 mA HART output	Compact version and 4...20 mA HART output only: SIL 2 - according to EN 61508 and for high/low demand mode operation
EMC	Electromagnetic Compatibility Directive 2004/108/EC in conjunction with EN 61326-1 (2006) SIL 2-approved devices agree with EN 61326-3-1 (2008) and EN 61326-3-2 (2008)
Construction Code	Metallic Horn and Wave Guide antennas: NACE MR0175 / ISO 15156; NACE MR0103

- ① If the process connection temperature is more than 150°C / 302°F and the device has Kalrez® 6375 or FKM/FPM gaskets, the device will also have an high temperature extension between the converter and the process connection. Kalrez® is a registered trademark of DuPont Performance Elastomers L.L.C. The process connection temperature must agree with the temperature limits of the gasket material.
- ② Metaglas® is a registered trademark of Herberts Industrieglas, GMBH & Co., KG
- ③ HART® is a registered trademark of the HART Communication Foundation
- ④ Only the 3.6 mA error signal is applicable to SIL-approved devices

BLISSWAVE 5200

DIMENSIONS AND WEIGHTS

Housing, Process Connection and Antenna options

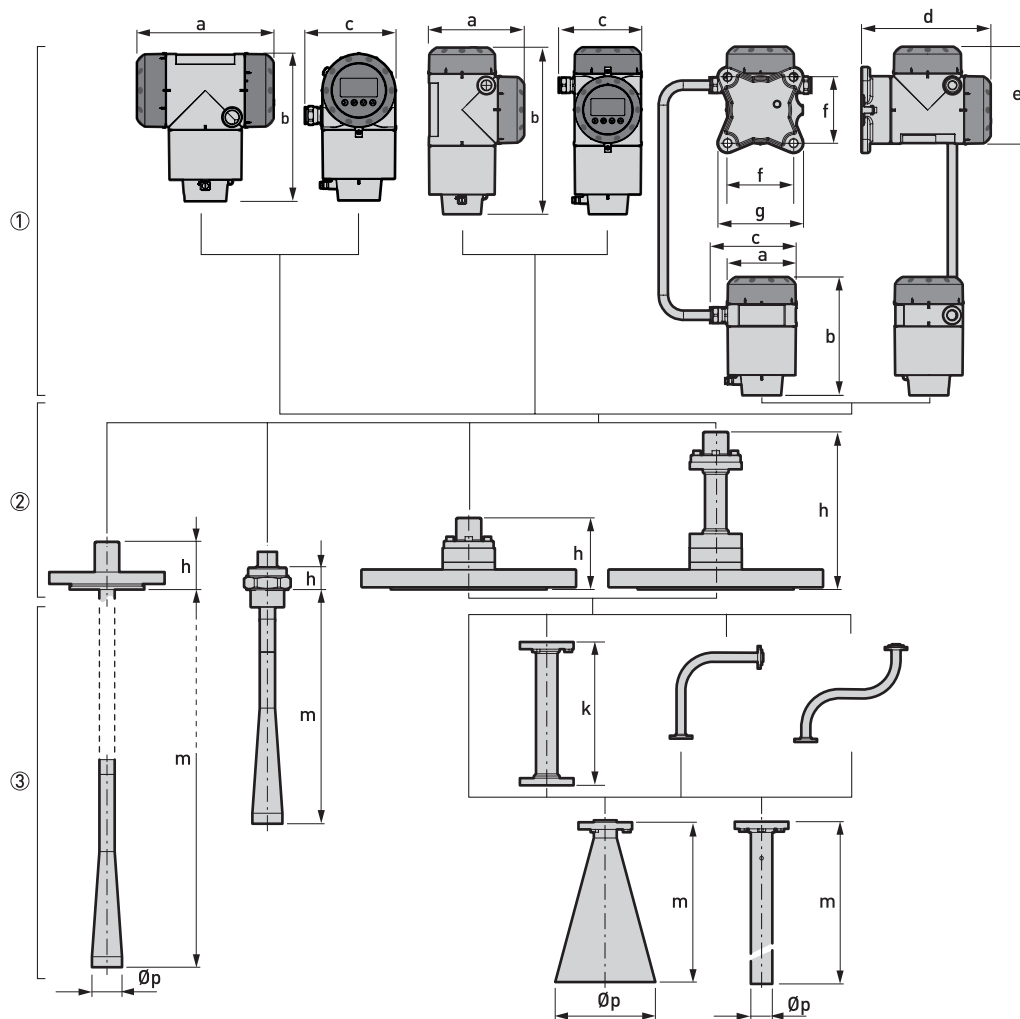

- 1 Housing options. From left to right: compact converter with horizontal housing, compact converter with vertical housing, and remote converter (top) and antenna housing (bottom)
- 2 Process connection options. From left to right: flange connection for PTFE Wave Horn antenna, threaded connection for PP Wave Horn antenna, flange connection for Metallic Horn and Wave Guide antennas, flange connection with a high-temperature (HT) extension for Metallic Horn and Wave Guide antennas
- 3 Antenna options. From left to right: PTFE Wave Horn antenna, PP Wave Horn antenna, Metallic Horn antenna (with or without an antenna extension option: straight, "L" or "S" extension), Wave Guide antenna

All housing covers have bayonet connectors unless it is an explosion-proof (XP / Ex d-approved) device. The terminal compartment cover for explosion-proof devices has a thread with a flame path



RADAR TRANSMITTERS

BLISSWAVE 5200

Housing Options: Dimensions in mm and inches

Dimensions	Compact - Horizontal		Compact - Vertical		Remote	
	Non-Ex or Ex i (Ex d)		Non-Ex or Ex i (Ex d)		Non-Ex or Ex i (Ex d)	
	[mm]	[inches]	[mm]	[inches]	[mm]	[inches]
a	191 (258)	7.5 (10.2)	147 (210)	5.79 (8.27)	104 (104)	4.09 (4.09)
b	214 (214)	8.43 (8.43)	258 (258)	10.16 (10.16)	181 (181)	7.13 (7.13)
c	127 (127)	5.00 (5.00)	127 (127)	5.00 (5.00)	129 (129)	5.08 (5.08)
d	-	-	-	-	195 (195)	7.68 (7.68)
e	-	-	-	-	146 (209)	5.75 (8.23)
f	-	-	-	-	100 (100)	3.94 (3.94)
g	-	-	-	-	130 (130)	5.12 (5.12)

Process Connection and Antenna Options: Dimensions in mm

Dimensions (mm)	PTFE Wave Horn	PP Wave Horn	Metallic Horn				Wave Guide
			DN80 / 3"	DN100 / 4"	DN150 / 6"	DN200 / 8"	
h	68	33	100 (220 for the HT extension) ①				
k	-	-	100, 200, 300, 400, 500, 1000 ②				
m	296 ③	322	112	148.5	223	335	1000...6000
Øp	43	43	80	100	140	200	30

- ① The HT extension is only for Metallic Horn and Wave Guide Antennas. It is attached between the signal converter and the flange if the Process Connection Temperature is +150...+250°C.
- ② These are the length options for the straight Antenna extension. For data about the dimensions of "S" and "L" extensions, refer to the illustrations that follow.
- ③ Other antenna lengths are available: 396, 496 or 596 mm. These options are for tanks with long nozzles.

Process Connection and Antenna Options: Dimensions in inches

Dimensions (mm)	PTFE Wave Horn	PP Wave Horn	Metallic Horn				Wave Guide
			DN80 / 3"	DN100 / 4"	DN150 / 6"	DN200 / 8"	
h	2.68	1.30	3.94 (8.66 for the HT extension) ①				
k	-	-	3.94, 7.87, 11.81, 15.75, 19.68 or 39.37 ②				
m	11.65 ③	12.68	4.41	5.85	8.78	13.19	39.4...236.2
Øp	1.69	1.69	3.15	3.94	5.51	7.87	1.18

- ① The HT extension is only for Metallic Horn and Wave Guide Antennas. It is attached between the signal converter and the flange if the Process Connection Temperature is +302...+482°F.
- ② These are the length options for the Straight Antenna Extension. For data about the dimensions of "S" and "L" extensions, refer to the illustrations that follow.
- ③ Other Antenna lengths are available: 15.59", 19.53" or 23.46". These options are for tanks with long nozzles.

BLISSWAVE 5200

**Special Antenna Extensions for tanks with obstructions
(DN150 / 6" and DN200 / 8" Metallic Horn Antenna options only)**

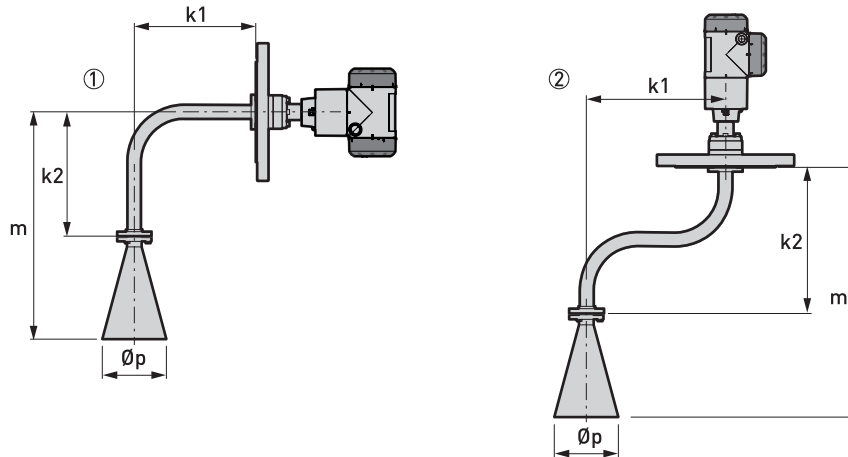

**Special Antenna Extensions for tanks with obstructions
(DN150 / 6" and DN200 / 8" Metallic Hornantenna options only)**

1. "L" (right angle) antenna extension
2. "S" antenna extension

Special Antenna Extensions: Dimensions in mm

Dimensions (mm)	Metallic Horn Antenna			
	With "L" (right angle) Extension		With "S" Extension	
	DN150 / 6"	DN200 / 8"	DN150 / 6"	DN200 / 8"
k1		271		300
k2		271		322
m	494	606	545	657
Øp	140	200	140	200

Special Antenna Extensions: Dimensions in inches

Dimensions (mm)	Metallic Horn Antenna			
	With "L" (right angle) Extension		With "S" Extension	
	DN150 / 6"	DN200 / 8"	DN150 / 6"	DN200 / 8"
k1		10.67		11.81
k2		10.67		12.68
m	19.45	23.86	21.46	25.87
Øp	5.51	7.87	5.51	7.87



RADAR TRANSMITTERS

BLISSWAVE 5200

Purging and Heating / Cooling System Options

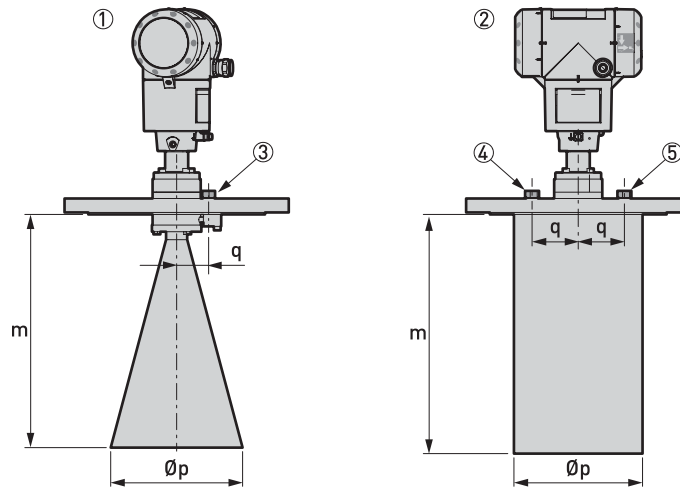

Purging and Heating / Cooling system options

- 1 Flange connection with purging option
- 2 Flange connection with heating/cooling system option
- 3 G ¼ threaded connection for purging system (the plug is supplied by the manufacturer)
- 4 G ¼ threaded connection for the heating/cooling system outlet (the plug is supplied by the manufacturer)
- 5 G ¼ threaded connection for the heating/cooling system inlet (the plug is supplied by the manufacturer)

Purging System and Heating / Cooling System: Dimensions in mm

Dimensions (mm)	Metallic Horn Antenna			
	Purging System		Heating/Cooling System	
	DN150 / 6"	DN200 / 8"	DN150 / 6"	DN200 / 8"
m	223	351	202	360 ①
Øp	140	200	139.7	195
q	34	34	53	70

① This is the standard length. Longer on request.

Purging System and Heating / Cooling System: Dimensions in inches

Dimensions (mm)	Metallic Horn Antenna			
	Purging System		Heating/Cooling System	
	DN150 / 6"	DN200 / 8"	DN150 / 6"	DN200 / 8"
m	8.78	13.82	8.0	14.17 ①
Øp	5.51	7.87	5.5	7.68
q	1.34	1.34	2.1	2.76

① This is the standard length. Longer on request.

All wetted parts (flange, antenna and heating/cooling jacket) of the heating/cooling system option are made of 316Ti / 1.4571

BLISSWAVE 5200

Weather Protection Option

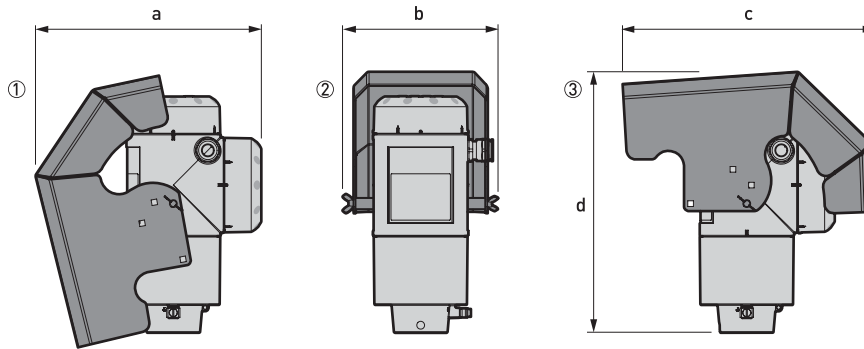

Weather protection option for Compact / Vertical and Remote versions

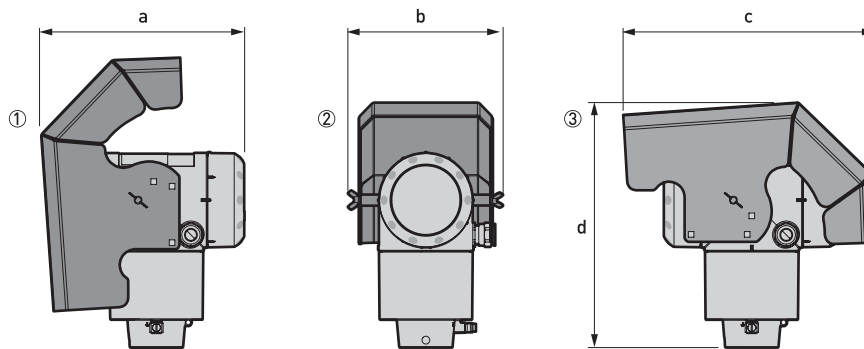

Weather protection option for Compact / Horizontal and Remote versions

1. Left side (with weather protection open)
2. Rear view (with weather protection closed)
3. Right side (with weather protection closed)

Dimensions and Weights in mm and kg

Weather Protection	Dimensions [mm]				Weights [kg]
	a	b	c	d	
Compact / Vertical or Remote versions	244	170	274	285	1.6
Compact / Horizontal or Remote versions	221	170	274	269	1.6

Dimensions and Weights in inches and lb

Weather Protection	Dimensions [inches]				Weights [kg]
	a	b	c	d	
Compact / Vertical or Remote versions	9.6	6.7	10.8	11.22	3.5
Compact / Horizontal or Remote versions	8.7	6.7	10.8	10.59	3.5



RADAR TRANSMITTERS

BLISSWAVE 5200

Converter and Antenna Housing Weights

Dimensions (mm)	Weights			
	Aluminum Housing		Stainless Steel Housing	
	[kg]	[lb]	[kg]	[lb]

Non-Ex / intrinsically-safe (Ex i / IS)

Compact	3.0	6.6	6.6	14.6
Remote Converter ①	2.5	5.5	5.9	13.0
Antenna Housing ①	2.0	4.4	4.1	9.0

Explosion proof (Ex d / XP)

Compact	3.2	7.1	7.5	16.5
Remote Converter ①	2.9	6.40	7.1	15.65
Antenna Housing ①	2.0	4.4	4.1	9.0

① The remote version of the device has a "Remote Converter" and an "Antenna Housing". For more data, refer to "Housing dimensions" at the start of this section.

Antenna Option Weights

Antenna Options	Min./Max. weights	
	[kg]	[lb]

Standard options, without converter

PTFE Wave Horn antenna with flange connection	3.7	8.2
PTFE Wave Horn antenna with flange connection, with 100 mm antenna extension	3.78	8.3
PTFE Wave Horn antenna with flange connection, with 200 mm antenna extension	3.86	8.5
PTFE Wave Horn antenna with flange connection, with 300 mm antenna extension	3.94	8.7
PP Wave Horn antenna with threaded connection	0.7	1.5
DN80 / 3" Metallic Horn antenna with flange connection, standard length	5.6...37.1	12.3...81.8
DN100 / 4" Metallic Horn antenna with flange connection, standard length	9.1...37.2	20.1...82
DN150 / 6" Metallic Horn antenna with flange connection, standard length	13.6...37.5	30...82.7
DN200 / 8" Metallic Horn antenna with flange connection, standard length	14.0...37.8	30.9...83.3
Wave Guide antenna with flange connection, 1...6 m / 3.28...19.68 ft	1.6...9.9	3.5...21.8



BLISSWAVE 5200

Antenna Options	Min./Max. Weights	
	[kg]	[lb]

Antenna Extension Options

Straight Extension, length 100 mm ①	+0.76	+1.68
Straight Extension, length 200 mm ①	+0.94	+2.07
Straight Extension, length 300 mm ①	+1.12	+2.47
Straight Extension, length 400 mm ①	+1.30	+2.87
Straight Extension, length 500 mm ①	+1.48	+3.26
Straight Extension, length 1000 mm ①	+2.38	+5.25
"S" Extension ①	+1.56	+3.44
"L" (right-angle) Extension ①	+1.48	+3.26

Other Options

HT Extension ②	+0.98	+2.16
----------------	-------	-------

- ① This option is for Metallic Horn and Wave Guide antenna options
- ② This component is only for the Metallic Horn and Wave Guide antennas. It is attached between the signal converter and the flange if the process connection temperature is +150...+250°C / +302...+482°F.



RADAR TRANSMITTERS

BLISSFLEX 1100 SELECTION GUIDE

The characters of the order code have been described below

Model Selection Guide			
BA25	4	BLISSFLEX 1100 C 2-wire loop-powered 4...20 mA Guided Radar (TDR) level meter: -50...+100°C and -1...16 barg / -58...212°F and -14.5...232 psig	
		Housing Material	
		1	Aluminum
		Probe type / Probe length (probe material)	
		3	Single Cable Ø2 mm / 0.08"; length 20 m / 65.6 ft (St. steel 316/1.4401)
		6	Single Cable Ø4 mm / 0.15"; length 10 m / 32.8 ft (St. steel 316/1.4401)
		A	Coaxial; 1 segment; length <730 mm / 29" (St. steel 316L/1.4404)
		B	Coaxial; 2 segments; length <1397 mm / 55" (St. steel 316L/1.4404)
		C	Coaxial; 3 segments; length <2065 mm / 81" (St. steel 316L/1.4404)
		D	Coaxial; 4 segments; length <2732 mm / 108" (St. steel 316L/1.4404)
		E	Coaxial; 5 segments; length <3400 mm / 134" (St. steel 316L/1.4404)
		F	Coaxial; 6 segments; length <4067 mm / 160" (St. steel 316L/1.4404)
		Process connection	
		2	G ¾A (ISO 228)
		3	G 1A (ISO 228)
		5	¾ NPT (ASME B1.20.1)
		6	1 NPT (ASME B1.20.1)
		Cable Entry / Cable Gland	
		1	M20 × 1.5 (F) / plastic
		2	½ NPT (F) (Brass) / without
		Display	
		1	Blind version
		2	With an integrated display
		Display language (English is supplied with all devices)	
		0	Without (for the blind version of the device)
		1	English
		2	German
		3	French
		4	Italian
		5	Spanish
		6	Portuguese
		7	Japanese
		8	Chinese (Mandarin)
		A	Russian
BA25	4	Order code	



BLISSFLEX 2200 SELECTION GUIDE

The characters of the order code have been described below

Model Selection Guide		
BA20	4	BLISSFLEX 2200 C/F Guided Radar (TDR) level transmitter Converter version (housing material / ingress protection)
		1 BLISSFLEX 2200 C: Compact version (aluminum – IP66/67)
		2 BLISSFLEX 2200 C: Compact version (stainless steel – IP66/67)
		3 BLISSFLEX 2200 F: Remote version (converter and probe housing: aluminum – IP66/67)
		4 BLISSFLEX 2200 F: Remote version (converter and probe housing: stainless steel – IP66/67)
		5 BLISSFLEX 2200 F: Remote version (converter housing: aluminum – IP66/67 and probe housing: stainless steel – IP66/67)
		Approval ①
		0 Without
		1 ATEX II 1/2 G Ex ia IIC T6 Ga/Gb + II 1/2 D Ex ia IIIC Da/Db
		2 ATEX II 1/2 G Ex d ia IIC T6 Ga/Gb + II 1/2 D Ex ia tb IIIC Da/Db
		4 ATEX II 3 G Ex ic IIC T6 Gc + II 3 D Ex ic IIIC Dc (Zone 2 and 22)
		6 IECEx Ex ia IIC T6 Ga/Gb + Ex ia IIIC Da/Db
		7 IECEx Ex d ia IIC T6 Ga/Gb + Ex ia tb IIIC Da/Db
		8 IECEx Ex ic IIC T6 Gc + Ex ic IIIC Dc (Zone 2 and 22)
		A cFMus IS CL I/II/III DIV 1 GPS A–G + CL I zone 0/20 Ex ia IIC/IIIC T6
		B cFMus XP-AIS/DIP CL I/II/III DIV 1 GPS A–G (A not for CAN) + CL I zone 0/20 Ex d[ia]/tb[ia] IIC/IIIC T6
		C cFMus NI CL I/II/III DIV 2 GPS A–G + CL I zone 2 Ex nA IIC T6
		L NEPSI Ex ia IIC T6 Ga/Gb + DIP A20/A21 ②
		M NEPSI Ex d ia IIC T6 Ga/Gb + DIP A20/A21 ②
		R INMETRO Ex ia IIC T6 Ga/Gb + Ex ia IIIC Da/Db
		S INMETRO Ex d ia IIC T6 Ga/Gb + Ex ia tb IIIC Da/Db
		T INMETRO Ex ic IIC T6 Gc + Ex ic IIIC Dc (Zone 2 and 22)
		Other Approval
		0 Without
		1 SIL2 – only available for the compact (C) version with the 4...20 mA output option
		4 CRN (Canadian Registration Number)
		5 CRN + SIL2 – only available for the compact (C) version with the 4...20 mA output option
		A WHG (overfill protection approval – only with calibration certificate)
		B EAC Russia
		C EAC Belarus
		D EAC Russia + SIL 2 – only available for the compact (C) version with the 4...20 mA output option
		E EAC Belarus + SIL 2 – only available for the compact (C) version with the 4...20 mA output option
		K EAC Kazakhstan
		L EAC Kazakhstan + SIL 2 – only available for the compact (C) version with the 4...20 mA output option
BA20	4	Order code (complete this code on the pages that follow)



RADAR TRANSMITTERS

BLISSFLEX 2200 SELECTION GUIDE

Order Code Continued...

Model Selection Guide			
			Process seal (temperature / pressure / material / notes)
		0	Without
		1	-40...+150°C (-40...+302°F) / -1...40 barg (-14.5...580 psig) / FKM/FPM (Viton) – for all probes
		2	-20...+150°C (-4...+302°F) / -1...40 barg (-14.5...580 psig) / Kalrez® 6375 – for all probes
		3	-50...+150°C (-58...+302°F) / -1...40 barg (-14.5...580 psig) / EPDM – for all probes
		6	-40...+300°C (-40...+572°F) / -1...40 barg (-14.5...580 psig) / FKM/FPM (Viton) – only for the high-temperature (HT) version of the Ø2 mm (0.08") single cable probe
		7	-20...+300°C (-4...+572°F) / -1...40 barg (-14.5...580 psig) / Kalrez® 6375 – only for the high-temperature (HT) version of the Ø2 mm (0.08") single cable probe
		8	-50...+250°C (-58...+482°F) / -1...40 barg (-14.5...580 psig) / EPDM – only for the high-temperature (HT) version of the Ø2 mm (0.08") single cable probe
			Probe (probe type / material / measuring range)
		0	Without
			For liquids only
		2	Single rod – Ø8 mm (0.32") segmented / 316L – 1.4404 / 1...6 m (3.28...19.69 ft)
		3	Single cable – Ø2 mm (0.08") / 316 – 1.4401 / 1...40 m (3.28...131.23 ft)
		6	Double rod – 2xØ8 mm (0.32") / 316L – 1.4404 / 1...4 m (3.28...13.12 ft)
		7	Double cable – 2xØ4 mm (0.16") / 316 – 1.4401 / 1...28 m (3.28...91.86 ft)
		D	Single cable – Ø2 mm (0.08") / HASTELLOY® C-22® / 1...40 m (3.28...131.23 ft)
		A	Coaxial – Ø22 mm (0.87") / 316L – 1.4404 / 0.6...6 m (1.97...19.69 ft)
		B	Coaxial – Ø22 mm (0.87") segmented / 316L – 1.4404 / 0.6...6 m (1.97...19.69 ft)
		E	Coaxial – Ø22 mm (0.87") / HASTELLOY® C-22® / 0.6...6 m (1.97...19.69 ft)
		P	Single rod – Ø8 mm (0.32") / PVDF sheath Ø16 mm (0.64") – not for cFMus – IIB only / 1...4 m (3.28...13.12 ft)
		T	Single cable – Ø4 mm (0.16") for BM 26 ADVANCED / 316L – 1.4404 / 1...6 m (3.28...19.69 ft)
		V	Single cable – Ø4 mm (0.16") for BM 26 F / 316L – 1.4404 / 1...6 m (3.28...19.69 ft)
			For liquids and solids
		1	Single rod – Ø8 mm (0.32") / 316L – 1.4404 / 1...6 m (3.28...19.69 ft)
		4	Single cable – Ø4 mm (0.16") / 316 – 1.4401 / liquids: 1...40 m (3.28...131.23 ft); solids: 1...20 m (3.28...65.92 ft)
			For solids only
		5	Single cable – Ø8 mm (0.32") / 316 – 1.4401 / 1...40 m (3.28...65.92 ft)
			Probe connection without probe
		K	Probe connection (316L – 1.4404) for single rod or single cable probe – probe not included – not available for single cable Ø2 mm (0.08")
		L	Probe connection (316L – 1.4404) for double rod or double cable probe – probe not included
BA20	4		Order code (complete this code on the pages that follow)



**BLISSFLEX 2200
SELECTION GUIDE**

Model Selection Guide			
			Probe end (probe end type / material / probe)
			0 Without
			1 Counterweight Ø14 × 100 mm (0.55 × 3.94") / 316L – 1.4404 / Single cable – Ø2 mm (0.08")
			F Counterweight Ø14 × 100 mm (0.55 × 3.94") / HASTELLOY® C-22® / Single cable – Ø2 mm (0.08")
			2 Counterweight Ø20 × 100 mm (0.79 × 3.94") / 316L – 1.4404 / Single cable – Ø4 mm (0.16")
			3 Counterweight Ø12 × 100 mm (0.47 × 3.94") / 316L – 1.4404 / Single cable – Ø8 mm (0.32")
			4 Counterweight Ø38 × 245 mm (1.50 × 9.65") / 316L – 1.4404 / Single cable – Ø8 mm (0.32")
			5 Counterweight Ø38 × 60 mm (1.50 × 2.36") / 316L – 1.4404 / Double cable – Ø4 mm (0.16")
			8 Chuck / 316L – 1.4404 / Single cable – Ø4 mm (0.16")
			B Crimped end / 316L – 1.4404 / Single cable – Ø4 mm (0.16")
			D Open end / 316L – 1.4404 / Single cable – Ø4 mm (0.16") and Ø8 mm (0.32")
			7 Turnbuckle / 316L – 1.4404 / Single/double cable – Ø4 mm (0.16")
			A Threaded end / 316L – 1.4404 / Single/double cable – Ø4 mm (0.16")
			L Centering counterweight / 316L – 1.4404 / Single cable – Ø4 mm (0.16") – for BM 26 F and BM 26 ADVANCED without float
			Process connection (size / pressure rating / flange finish)
			0 0 0 Without
			Threaded – ISO 228
			C P 0 G ½ ③
			D P 0 G ¾A ④
			E P 0 G 1A ④
			G P 0 G 1½A
			Threaded – ASME B1.20.1
			C B 0 ½ NPTF – B1.20.3 (Dryseal) ③
			D A 0 ¾ NPT ④
			E A 0 1 NPT ④
			G A 0 1½ NPT
			EN 1092-1 Flanges ⑤
			E D 1 DN25 PN10 – Type B1 ⑥
			E E 1 DN25 PN16 – Type B1 ⑥
			E F 1 DN25 PN25 – Type B1 ⑥
			E G 1 DN25 PN40 – Type B1 ⑥
			G D 1 DN40 PN10 – Type B1
			G E 1 DN40 PN16 – Type B1
			G F 1 DN40 PN25 – Type B1
			G G 1 DN40 PN40 – Type B1 / BM 26 ADVANCED
			H D 1 DN50 PN10 – Type B1
			H E 1 DN50 PN16 – Type B1
			H F 1 DN50 PN25 – Type B1
			H G 1 DN50 PN40 – Type B1
BA20	4		Order code (complete this code on the pages that follow)



RADAR TRANSMITTERS

BLISSFLEX 2200 SELECTION GUIDE

Model Selection Guide			
L	D	1	DN80 PN10 – Type B1
L	E	1	DN80 PN16 – Type B1
L	F	1	DN80 PN25 – Type B1
L	G	1	DN80 PN40 – Type B1
M	D	1	DN100 PN10 – Type B1
M	E	1	DN100 PN16 – Type B1
M	F	1	DN100 PN25 – Type B1
M	G	1	DN100 PN40 – Type B1
P	D	1	DN150 PN10 – Type B1
P	E	1	DN150 PN16 – Type B1
P	F	1	DN150 PN25 – Type B1
P	G	1	DN150 PN40 – Type B1
R	E	1	DN200 PN16 – Type B1
R	G	1	DN200 PN40 – Type B1 (for non-Ex devices only)
ASME B16.5 / ANSI Flanges ⑦			
E	1	A	1" 150 lb RF ⑥
E	2	A	1" 300 lb RF ⑥
G	1	A	1½" 150 lb RF
G	2	A	1½" 300 lb RF
H	1	A	2" 150 lb RF
H	2	A	2" 300 lb RF / BM 26 F
L	1	A	3" 150 lb RF
L	2	A	3" 300 lb RF
M	1	A	4" 150 lb RF
M	2	A	4" 300 lb RF
P	1	A	6" 150 lb RF
P	2	A	6" 300 lb RF (for non-Ex devices only)
R	1	A	8" 150 lb RF
R	2	A	8" 300 lb RF (for non-Ex devices only)
JIS B2220 Flanges			
G	U	P	40A JIS 10K RF
H	U	P	50A JIS 10K RF
L	U	P	80A JIS 10K RF
M	U	P	100A JIS 10K RF
P	U	P	150A JIS 10K RF
R	U	P	200A JIS 10K RF
Alternative flange faces			
	2		Type B2, EN 1092-1 (surface roughness must be specified in the order)
	3		Type C, EN 1092-1 (Tongue)
	4		Type D, EN 1092-1 (Groove)
	5		Type E, EN 1092-1 (Spigot)
	6		Type F, EN 1092-1 (Recess)
BA20	4	Order code (complete this code on the pages that follow)	



**BLISSFLEX 2200
SELECTION GUIDE**

Order Code Continued...

Model Selection Guide											
										B	FF, ASME B16.5 (Flat face)
										M	RJ, ASME B16.5 (Ring joint)
										C	LG, ASME B16.5 (Large groove)
										D	LF, ASME B16.5 (Large female)
										E	LT, ASME B16.5 (Large tongue)
										F	LM, ASME B16.5 (Large male)
										G	SG, ASME B16.5 (Small groove)
										H	SF, ASME B16.5 (Small female)
										K	ST, ASME B16.5 (Small tongue)
										L	SM, ASME B16.5 (Small male)
											Output
										1	2-wire / 4...20 mA passive HART
										2	2-wire / FOUNDATION™ fieldbus
										3	2-wire / PROFIBUS PA
											Cable entry / cable gland
										1	M20×1.5 (F) / Without
										2	M20×1.5 (F) / Plastic
										3	M20×1.5 (F) / Brass
										4	M20×1.5 (F) / Stainless steel
										A	½ NPT (F) (brass) / Without
										B	½ NPT (F) (stainless steel) / Without
											Housing (orientation / display / weather protection)
										0	Without
										1	Horizontal / No display / Without (for the compact version only)
										2	Horizontal / Display on side / Without (for the compact version only)
										3	Horizontal / No display / With (for the compact version only)
										4	Horizontal / Display on side / With (for the compact version only)
										A	Vertical / No display / Without
										B	Vertical / Display on top / Without
										C	Vertical / Display on side / Without (not available for Ex d ia / XP-approved devices)
										D	Vertical / No display / With
										E	Vertical / Display on top / With
										F	Vertical / Display on side / With (not available for Ex d ia / XP-approved devices)
BA20	4									Order code (complete this code on the pages that follow)	



RADAR TRANSMITTERS

BLISSFLEX 2200 SELECTION GUIDE

Order Code Continued...

Model Selection Guide													
													Display language (English is supplied with all devices)
													0 Without (if no display)
													1 English
													2 German
													3 French
													4 Italian
													5 Spanish
													6 Portuguese
													7 Japanese
													8 Chinese (simplified)
													A Russian
													Version
													0 Standard orders and orders for solid applications in China
													6 Orders for the USA
													A Orders for liquid applications in China
													0 Options for remote (F) version
													0 Without
													6 Signal cable 10 m (32.81 ft) (non-Ex: grey, Ex: blue)
													7 Signal cable 25 m (82.02 ft) (non-Ex: grey, Ex: blue)
													8 Signal cable 50 m (164.04 ft) (non-Ex: grey, Ex: blue)
													A Signal cable 75 m (246.06 ft) (non-Ex: grey, Ex: blue)
													B Signal cable 100 m (328.08 ft) (non-Ex: grey, Ex: blue)
													Adaptor
													0 Without
													1 BM100A adaptor
													2 BM102 adaptor
													3 BLISSFLEX 1300 adaptor (for devices made before 2009)
BA20	4												0 Order code (complete this code on the pages that follow)



BLISSFLEX 2200 SELECTION GUIDE

Order Code Continued...

Model Selection Guide														
													Calibration Certificate	
													0	Without – for accuracy ± 10 mm (± 0.39 ") up to 10 m (32.81 ft)
													1	Calibration certificate 2 points – for accuracy ± 3 mm (± 0.12 ") up to 10 m (32.81 ft) (for coaxial >600 mm (23.62") – other Probes: 1st point >500 mm (19.69"))
													2	Calibration certificate 5 points – for accuracy ± 3 mm (± 0.12 ") up to 10 m (32.81 ft) (for coaxial >1000 mm (39.37") – other Probes: 1st point >500 mm (19.69"))
													3	Calibration certificate 5 points, customer specific – for accuracy ± 3 mm (± 0.12 ") up to 10 m (32.81 ft) (not for coaxial – calibration points to be given by the customer: 1st point >500 mm (19.69"))
													Drawing/TAG Number	
													0	Without
													2	Tag No. on stainless steel plate (18 characters max.)
													Extra option	
													0	Without
														1 NACE design (MR0175 / MR0103 / ISO 15156)
BA20	4											0	Order code	

- ① For more data, refer to the Technical data section (Approvals and Certification)
- ② DIP= Dust Ignition Proof
- ③ For $\varnothing 2$ mm / 0.08" single cable probes only
- ④ Do not use with double rod and double cable probes
- ⑤ Other flange faces are available. Refer to your local supplier for more data.
- ⑥ Do not use with double rod, double cable and coaxial probes
- ⑦ Flanges with RF faces have a slip on-type design with an anti-blowout feature. Other flange faces are available. Refer to your local supplier for more data.



RADAR TRANSMITTERS

BLISSFLEX 1010 SELECTION GUIDE

Make a selection from each column to get the full order code.

Model Selection Guide		
BA01	4	BLISSWAVE 1010 Non-Contact Radar (FMCW) Level Transmitter
		Converter version (Housing material – protection class)
	1	BLISSWAVE 1010: Compact version (Aluminum – IP66 / IP67)
	2	BLISSWAVE 1010: Compact version (Stainless Steel – IP66 / IP67)
		Approval ①
	0	Without
	1	ATEX II 1/2 G Ex ia IIC Tx Ga/Gb + II 2 D Ex ia IIIC T120°C ②
	2	ATEX II 1/2 G Ex db IIC T6...T4 Ga/Gb + II 2 D Ex tb IIIC T120°C Db ③
	6	IECEX Ex ia IIC Tx Ga/Gb + Ex ia IIIC T120°C Db ④
	7	IECEX Ex db IIC T6...T4 Ga/Gb + Ex tb IIIC T120°C Db ⑤
		Other Approval
	0	Without
	B	EAC Russia ⑥
	C	EAC Belarus ⑥
	K	EAC Kazakhstan ⑥
		Process Seal – Temperature / Pressure / Material / Remarks (material to be checked by the customer)
	0	Without
	1	-40°C...+100°C (-40°F...+212°F) / -1...16 barg (-14.5...232 psig) / FKM/FPM / aluminum housing and Metapeek process seal
	2	-40°C...+100°C (-40°F...+212°F) / -1...16 barg (-14.5...232 psig) / EPDM / aluminum housing and Metapeek process seal
	3	-20°C...+100°C (-4°F...+212°F) / -1...16 barg (-14.5...232 psig) / Kalrez® 6375 / aluminum housing and Metapeek process seal
	5	-40°C...+150°C (-40°F...+302°F) / -1...40 barg (-14.5...580 psig) / FKM/FPM / aluminum housing, Metaglas® process seal and distance piece
	6	-40°C...+150°C (-40°F...+302°F) / -1...40 barg (-14.5...580 psig) / EPDM / aluminum housing, Metaglas® process seal and distance piece
	7	-20°C...+150°C (-4°F...+302°F) / -1...40 barg (-14.5...580 psig) / Kalrez® 6375 / aluminum housing, Metaglas® process seal and distance piece
	A	-40°C...+120°C (-40°F...+248°F) / -1...40 barg (-14.5...580 psig) / FKM/FPM / stainless steel housing and Metaglas® process seal
	B	-40°C...+120°C (-40°F...+248°F) / -1...40 barg (-14.5...580 psig) / EPDM / stainless steel housing and Metaglas® process seal
	C	-20°C...+120°C (-4°F...+248°F) / -1...40 barg (-14.5...580 psig) / Kalrez® 6375 / stainless steel housing and Metaglas® process seal
BA01	4	Order code (complete this code on the pages that follow)



BLISSWAVE 1010 SELECTION GUIDE

Order Code Continued...

Model Selection Guide													
													Antenna: Matching Element / Material
													0 Without
													1 Metallic Horn for pipe Ø42.4 x 2 / 316L
													0 0 0 0 Output
													1 2-wire / 4...20mA passive HART
													Cable Entry / Cable Gland
													1 M20x1.5 (F) / Without
													2 M20x1.5 (F) / Plastic
													3 M20x1.5 (F) / Nickel-plated brass
													4 M20x1.5 (F) / Stainless Steel
													A ½ NPT (F) (nickel-plated brass) / Without
													B ½ NPT (F) (Stainless Steel) / Without
													Housing (Orientation / Display / Weather protection)
													A Vertical / Without / Without
													D Vertical / Without / With
													0 Version
													0 (RAL 9006 / RAL 5005)
													6 USA (FCC)
													A KMIC L (for liquid applications)
													0 0 0 Calibration certificate
													0 Without
													1 Calibration certificate 2 factory default points for accuracy ±5 mm (0.2")
													TAG Number
													0 Without
													2 Tag No. on stainless steel plate (18 characters max.)
													Other constructions
													0 Without
													1 NACE design (MR 0175 / MR 0103 / ISO 15156)
BA01	4												Order code

- ① For more data, refer to the Technical data section (Approvals and Certification)
- ② The dust approval is only applicable to the stainless steel housing. The bypass chamber or BM MLG must be approved for ATEX applications.
- ③ For the stainless steel housing only. The bypass chamber or BM MLG must be approved for ATEX applications.
- ④ The dust approval is only applicable to the stainless steel housing.
- ⑤ For the stainless steel housing only
- ⑥ Pending



RADAR TRANSMITTERS

BLISSWAVE 5200 SELECTION GUIDE

Make a selection from each column to get the full order code.

Model Selection Guide		
BA50	4	BLISSWAVE 5200 C/F Non-Contact Radar (FMCW) Level Meter
		Converter / Version (Housing material)
	0	Without
	1	BLISSWAVE 5200 C / Compact (Aluminum housing)
	2	BLISSWAVE 5200 C / Compact (Stainless Steel housing)
	3	BLISSWAVE 5200 F / Sensor (Aluminum housing) with Remote electronic (Aluminum housing) ①
	4	BLISSWAVE 5200 F / Sensor (Stainless Steel housing) with Remote electronic (Stainless Steel housing) ①
	5	BLISSWAVE 5200 F / Sensor (Stainless Steel housing) with Remote electronic (Aluminum housing) ①
		Approval ②
	0	Without
	1	ATEX Ex ia IIC T2...T6 + DIP ③
	2	ATEX Ex d ia IIC T2..T6 + DIP ③
	4	ATEX Ex ic IIC T2...T6 + DIP (Zone 2 and 22) ③
	6	IECEX Ex ia IIC T2...T6 + DIP ③
	7	IECEX Ex d ia IIC T2...T6 + DIP ③
	8	IECEX Ex ic IIC T2...T6 + DIP (Zone 2 and 22) ③
	A	cFMus IS Cl. I/II/III Div. 1 Gr. A-G; Cl. I Zone 0/20, Ex ia IIC/IIC T2...T6 ①
	B	cFMus IS-XP/DIP Cl. I/II/III Div. 1, Gr. A-G (A not for Canada); Cl. I Zone 0/20, Ex d/tb IIC/IIC T2...T6 ①
	C	cFMus NI Cl. I/II/III Div. 2, Gr. A-G; Cl. I Zone 2, Ex nA IIC T2...T6 ①
	L	NEPSI Ex ia IIC T2...T6 + DIP ③
	M	NEPSI Ex d ia IIC T2...T6 + DIP ③
		Other approval
	0	Without
	1	SIL2 (for the compact version (C) with a 4...20 mA output only)
	4	CRN (Canadian Registration Number)
	5	CRN + SIL2 (for the compact version (C) with a 4...20 mA output only)
BA50	4	Order code (complete this code on the pages that follow)



BLISSWAVE 5200 SELECTION GUIDE

Order Code Continued...

Model Selection Guide		
		Pressure / Temperature / Sealing (higher flange temperature and process pressure on request)
	0	Without
	1	40 bar / -40°C...+150°C (-40°F...+302°F) / FKM, FPM - for the Metallic Horn antenna and Wave Guide
	5	40 bar / -50°C...+130°C (-58°F...+266°F) / EPDM - for the Metallic Horn antenna and Wave Guide
	6	40 bar / -20°C...+150°C (-4°F...+302°F) / Kalrez 6375 - for the Metallic Horn antenna and Wave Guide
	A	40 bar / -60°C...+130°C (-76°F...+266°F) / PFA - for the Metallic Horn antenna and Wave Guide
	D	40 bar / -40°C...+200°C (-40°F...+392°F) / FKM (Viton) - for the Metallic Horn antenna and Wave Guide
	K	40 bar / -20°C...+250°C (-4°F...+482°F) / Kalrez 6375 - for the Metallic Horn antenna and Wave Guide
	R	16 bar / -20°C...+100°C (-4°F...+212°F) / PP - for the PP Wave Horn antenna
	T	40 bar / -50°C...+150°C (-58°F...+302°F) / PTFE - for the PTFE Wave Horn antenna
		Material and Antenna
	0	Without
	1	316L / Metallic horn (sheet metal) DN80 (3") L = 110 mm (4.3")
	2	316L / Metallic horn (sheet metal) DN100 (4") L = 148 mm (5.8")
	3	316L / Metallic horn (sheet metal) DN150 (6") L = 223 mm (8.8")
	4	316L / Metallic horn (sheet metal) DN200 (8") L = 335 mm (13.2")
	G	PP / Wave Horn Ø43 mm (1.7"), maximum socket length 200 mm / 7.9"
	H	PTFE / Wave Horn Ø43 mm (1.7"), maximum nozzle length 200 mm / 7.9"
	L	316L / Metallic wave guide Ø30 mm (1.2") ≤1 m (3.28 ft)
	M	316L / Metallic wave guide Ø30 mm (1.2") ≤1.5 m (4.92 ft)
	N	316L / Metallic wave guide Ø30 mm (1.2") ≤2 m (6.56 ft)
	P	316L / Metallic wave guide Ø30 mm (1.2") ≤2.5 m (8.2 ft)
	R	316L / Metallic wave guide Ø30 mm (1.2") ≤3 m (9.84 ft)
	S	316L / Metallic wave guide Ø30 mm (1.2") ≤3.5 m (11.48 ft)
	T	316L / Metallic wave guide Ø30 mm (1.2") ≤4 m (13.12 ft)
	U	316L / Metallic wave guide Ø30 mm (1.2") ≤4.5 m (14.76 ft)
	V	316L / Metallic wave guide Ø30 mm (1.2") ≤5 m (16.4 ft)
	W	316L / Metallic wave guide Ø30 mm (1.2") ≤5.5 m (18.04 ft)
	X	316L / Metallic wave guide Ø30 mm (1.2") ≤6 m (19.68 ft)
BA50	4	Order code (complete this code on the pages that follow)



RADAR TRANSMITTERS

BLISSWAVE 5200 SELECTION GUIDE

Model Selection Guide										
										Material and Antenna Extension
										0 Without
										6 PTFE, antenna extension for maximum nozzle length 300 mm / 11.8" ④
										7 PTFE, antenna extension for maximum nozzle length 400 mm / 15.7" ④
										8 PTFE, antenna extension for maximum nozzle length 500 mm / 19.7" ④
										E 316L / 100 mm (4") for the Metallic Horn antenna option only ④
										F 316L / 200 mm (8") for the Metallic Horn antenna option only ④
										G 316L / 300 mm (12") for the Metallic Horn antenna option only ④
										H 316L / 400 mm (16") for the Metallic Horn antenna option only ④
										K 316L / 500 mm (20") for the Metallic Horn antenna option only ④
										R 316L / 1000 mm (40") for the Metallic Horn antenna option only ④
										W 316L / "S" extension ④
										X 316L / "L" (right angle) extension ④
										Process Connection: Size / Pressure rating / Flange finish
										0 0 0 Without
										Threaded - ISO 228
										G P 0 G 1½ 5
										Threaded - ASME B1.20.1
										G A 0 1½ NPT 5
										EN / DIN Flanges - EN 1092-1 ⑥
										H E 1 DN50 PN16 - Form B1 flange ⑦
										H G 1 DN50 PN40 - Form B1 flange ⑦
										L E 1 DN80 PN16 - Form B1 flange
										L G 1 DN80 PN40 - Form B1 flange
										M E 1 DN100 PN16 - Form B1 flange
										M G 1 DN100 PN40 - Form B1 flange
										P E 1 DN150 PN16 - Form B1 flange
										P G 1 DN150 PN40 - Form B1 flange
										R E 1 DN200 PN16 - Form B1 flange ⑧
										R G 1 DN200 PN40 - Form B1 flange ⑧
										ASME B16.5 / ANSI Flanges ⑥
										H 1 A 2" 150 lb RF ⑦
										H 2 A 2" 300 lb RF ⑦
										L 1 A 3" 150 lb RF
										L 2 A 3" 300 lb RF
										M 1 A 4" 150 lb RF
										M 2 A 4" 300 lb RF
										P 1 A 6" 150 lb RF
										P 2 A 6" 300 lb RF
										R 1 A 8" 150 lb RF ⑧
										R 2 A 8" 300 lb RF ⑧
BA50	4									Order code (complete this code on the pages that follow)



BLISSWAVE 5200 SELECTION GUIDE

Order Code Continued...

Model Selection Guide										
										JIS B2220 Flanges
										H U P 10K 50A RF ⑦
										L U P 10K 80A RF
										M U P 10K 100A RF
										P U P 10K 150A RF
										R U P 10K 200A RF ⑧
										Alternative flange faces
										0 Without
										2 Form B2, EN 1092-1 (surface roughness must be specified in the order)
										3 Form C, EN 1092-1 (Tongue)
										4 Form D, EN 1092-1 (Groove)
										5 Form E, EN 1092-1 (Male)
										6 Form F, EN 1092-1 (Female)
										B FF, ASME B16.5 (Flat face)
										Output
										1 2-wire / 4...20mA passive HART
										A 2-wire / FOUNDATION™ fieldbus (for the compact version only)
										B 2-wire / PROFIBUS PA (for the compact version only)
										Cable entry / Cable gland
										1 M20×1.5 (F) / without
										2 M20×1.5 (F) / Plastic (Non-Ex: black; Ex i: blue)
										3 M20×1.5 (F) / Brass
										4 M20×1.5 (F) / Stainless Steel
										A ½ NPT (F) (Brass) / without
										B ½ NPT (F) (Stainless Steel) / without
										Housing option / Display
										1 Horizontal housing / No display (for the compact version only)
										2 Horizontal housing / Display (for the compact version only)
										3 Horizontal housing / No display + Weather protection (for the compact version only)
										4 Horizontal housing / Display + Weather protection (for the compact version only)
										A Vertical housing / No display
										B Vertical housing / Display top
										C Vertical housing / Display side (not available for Ex d ia / XP-approved devices)
										D Vertical housing / No display + Weather protection
										E Vertical housing / Display top + Weather protection
										F Vertical housing / Display side + Weather protection (not available for Ex d ia / XP-approved devices)
BA50	4									Order code (complete this code on the pages that follow)n



RADAR TRANSMITTERS

BLISSWAVE 5200 SELECTION GUIDE

Order Code Continued...

Model Selection Guide											
										Display language	
										0	Without
										1	English
										2	German
										3	French
										4	Italian
										5	Spanish
										6	Portuguese
										7	Japanese
										8	Chinese (Mandarin)
										A	Russian
											Version
										0	Standard orders and orders for solid applications in China
										6	Orders with FCC radio approval (FCC Part 15 and RSS-210)
										A	Orders for liquid applications in China
										0	Remote option
										0	Without
										6	Signal cable 10m / Grey (std) or Blue (Ex) (Remote version only)
										7	Signal cable 25m / Grey (std) or Blue (Ex) (Remote version only)
										8	Signal cable 50m / Grey (std) or Blue (Ex) (Remote version only)
										A	Signal cable 75m / Grey (std) or Blue (Ex) (Remote version only)
										B	Signal cable 100m / Grey (std) or Blue (Ex) (Remote version only)
											Adaptor
										0	Without
										1	Adaptor for BM70x flange system
											Calibration certificate
										0	Without
										1	Calibration certificate ±5 mm 2 points
											TAG Number
										0	Without
										2	Tag No. stainless steel plate (16 characters max.)
BA50	4									Order code (complete this code on the pages that follow)	



**BLISSWAVE 5200
SELECTION GUIDE**

Order Code Continued...

Model Selection Guide																	
																Extra option	
																0	Without
																1	NACE design (MR0175 / MR0103 / ISO 15156)
																3	Heating / Cooling ⑨
																5	Purging ⑨
																6	Purging + Heating / Cooling ⑨
BA50	4													0		Order code	

- ① Only for the "4...20 mA passive HART" output option
- ② For more data, refer to the Technical data section (Approvals and certification)
- ③ DIP= Dust Ignition Proof
- ④ For device dimensions, refer to the "Dimensions and weights" section
- ⑤ For the PP Wave Horn antenna option only
- ⑥ Other flange faces are available. Refer to your local supplier for more data. Flanges with the PTFE Wave Horn antenna option have a slip on-type design with an anti-blowout feature.
- ⑦ Minimum flange size for the PTFE Wave Horn antenna. This is not available for the Metallic Horn antenna.
- ⑧ This flange is not available for the PTFE Wave Horn antenna option
- ⑨ For DN150 and DN200 Metallic Horn antenna only



RADAR TRANSMITTERS

cFMUS CERTIFICATION - USA

CERTIFICATE OF CONFORMITY



1. **HAZARDOUS (CLASSIFIED) LOCATION ELECTRICAL EQUIPMENT PER US REQUIREMENTS**
2. **Certificate No:** FM16US0269
3. **Equipment:
(Type Reference and Name)** BlissWave 5200 C, BlissWave 5200 F, BlissFlex 2200 C, BlissFlex 2200 F
4. **Name of Listing Company:** Bliss Anand America LLC
5. **Address of Listing Company:** 3400 Awesome Ln
La Porte, TX 77571
United States
6. The examination and test results are recorded in confidential report number:

3059953 dated 10th November 2016
7. FM Approvals LLC, certifies that the equipment described has been found to comply with the following Approval standards and other documents:

FM Class 3600:2011, FM Class 3610:2010, FM Class 3611:2004, FM Class 3615:2006, FM Class 3616:2011, FM Class 3810:2005, ANSI/ISA 60079-0:2009, ANSI/ISA 60079-1:2009, ANSI/ISA 60079-11:2011, ANSI/ISA 60079-15:2009, ANSI/ISA 60079-31:2009, ANSI/ISA 12.27-01:2003, ANSI/NEMA 250:2008, ANSI/IEC 60529:2004, ANSI/ISA 61010-1(82.02.01):2004
8. If the sign 'X' is placed after the certificate number, it indicates that the equipment is subject to specific conditions of use specified in the schedule to this certificate.
9. This certificate relates to the design, examination and testing of the products specified herein. The FM Approvals surveillance audit program has further determined that the manufacturing processes and quality control procedures in place are satisfactory to manufacture the product as examined, tested and Approved.

Certificate issued by:



J.E. Marquedant
Manager, Electrical Systems

10 November 2016

Date

To verify the availability of the Approved product, please refer to www.approvalguide.com

THIS CERTIFICATE MAY ONLY BE REPRODUCED IN ITS ENTIRETY AND WITHOUT CHANGE

FM Approvals LLC, 1151 Boston-Providence Turnpike, Norwood, MA 02062 USA
T: +1 (1) 781 762 4300 F: +1 (1) 781 762 9375 E-mail: information@fmapprovals.com www.fmapprovals.com



cFMus CERTIFICATION - CANADA

CERTIFICATE OF CONFORMITY



1. **HAZARDOUS LOCATION ELECTRICAL EQUIPMENT PER CANADIAN REQUIREMENTS**
2. **Certificate No:** FM16CA0138
3. **Equipment:** BlissWave 5200 C, BlissWave 5200 F, BlissFlex 2200 C, BlissFlex 2200 F
(Type Reference and Name)
4. **Name of Listing Company:** Bliss Anand America LLC
5. **Address of Listing Company:** 3400 Awesome Ln
La Porte, TX 77571
United States
6. The examination and test results are recorded in confidential report number:

3059953 dated 10th November 2016
7. FM Approvals LLC, certifies that the equipment described has been found to comply with the following Approval standards and other documents:

CSA-C22.2 No. 0-M91:R2006, CSA-C22.2 No. 0.4-04:2004, CSA-C22.2 No. 0.4-05:R2008, CSA-C22.2 No. 25:R2009, CSA-C22.2 No. 30:R2007, CSA-C22.2 No. 94-M91:R2006, CSA-C22.2 No. 142-M1987:R2009, CSA-C22.2 No. 213:R2008, CSA-C22.2 No. 157-92:R2012, CSA-C22.2 No. 60529:2005, CAN/CSA-C22.2 No. 60079-0:2011, CAN/CSA-C22.2 No. 60079-1:2011, CAN/CSA-C22.2 No. 60079-11:2011, CAN/CSA-C22.2 No. 60079-15:2012, CAN/CSA-C22.2 No. 1010.1:2004, ANSI/ISA 12.27.-01:2003
8. If the sign 'X' is placed after the certificate number, it indicates that the equipment is subject to specific conditions of use specified in the schedule to this certificate.
9. This certificate relates to the design, examination and testing of the products specified herein. The FM Approvals surveillance audit program has further determined that the manufacturing processes and quality control procedures in place are satisfactory to manufacture the product as examined, tested and Approved.

Certificate issued by:

J.E. Marquedant
 J.E. Marquedant
 Manager, Electrical Systems

10 November 2016
 Date

To verify the availability of the Approved product, please refer to www.approvalguide.com

THIS CERTIFICATE MAY ONLY BE REPRODUCED IN ITS ENTIRETY AND WITHOUT CHANGE

FM Approvals LLC, 1151 Boston-Providence Turnpike, Norwood, MA 02062 USA
 T: +1 (1) 781 762 4300 F: +1 (1) 781 762 9375 E-mail: information@fmapprovals.com www.fmapprovals.com



RADAR TRANSMITTERS

ATEX CERTIFICATION- EU TYPE EXAMINATION

DEKRA

CERTIFICATE

(1) **EU-Type Examination**

(2) **Equipment or protective systems intended for use in potentially explosive atmospheres - Directive 2014/34/EU**

(3) EU-Type Examination Certificate Number: **DEKRA 17ATEX0001 X** Issue Number: **0**

(4) **Product:** **Guided Radar (TDR) Level Transmitter BLISSFLEX 2200 C/F Type "BA20"..... and Radar (FMCW) Level Transmitter BLISSWAVE 5200 C/F Type "BA50".....**

(5) **Manufacturer:** **Bliss Anand America LLC**

(6) **Address:** **3400 Awesome Lane, La Porte, Texas 77571, U.S.A.**

(7) This product and any acceptable variation thereto is specified in the schedule to this certificate and the documents therein referred to.

(8) DEKRA Certification B.V., Notified Body number 0344 in accordance with Article 17 of Directive 2014/34/EU of the European Parliament and of the Council, dated 26 February 2014, certifies that this product has been found to comply with the Essential Health and Safety Requirements relating to the design and construction of products intended for use in potentially explosive atmospheres given in Annex II to the Directive.

The examination and test results are recorded in confidential test report number 219065400-1.

(9) Compliance with the Essential Health and Safety Requirements has been assured by compliance with:

EN 60079-0 : 2009	EN 60079-1 : 2007	EN 60079-31 : 2009
EN 60079-11 : 2012	EN 60079-26 : 2007	

except in respect of those requirements listed at item 18 of the Schedule.

(10) If the sign "X" is placed after the certificate number, it indicates that the product is subject to the Specific Conditions of Use specified in the schedule to this certificate.

(11) This EU-Type Examination Certificate relates only to the design and construction of the specified product. Further requirements of the Directive apply to the manufacturing process and supply of this product. These are not covered by this certificate.

(12) The marking of the product shall include the following:

 **For marking see section 15.**

Date of certification: 16 January 2017

DEKRA Certification B.V.



R. Schuller
Certification Manager

Page 1/8

 ® Integral publication of this certificate and adjoining reports is allowed. This Certificate may only be reproduced in its entirety and without any change.

DEKRA Certification B.V. Meander 1051, 6825 MJ Arnhem P.O. Box 5185, 6802 ED Arnhem The Netherlands
T +31 88 96 83000 F +31 88 96 83100 www.dekra-certification.com Registered Arnhem 09085398



**ATEX CERTIFICATION-
TYPE EXAMINATION**



CERTIFICATE

- (1) **Type Examination**
- (2) **Product intended for use in potentially explosive atmospheres - Directive 2014/34/EU**
- (3) Type Examination Certificate Number: **DEKRA 17ATEX0002 X** Issue Number: **0**
- (4) **Product:** Guided Radar (TDR) Level Transmitter BLISSFLEX 2200 C/F
Type "BA20"..... and
Radar (FMCW) Level Transmitter BLISSWAVE 5200 C/F
Type "BA50".....
- (5) **Manufacturer:** Bliss Anand America LLC
- (6) **Address:** 3400 Awesome Lane, La Porte, Texas 77571, U.S.A.
- (7) This product and any acceptable variation thereto is specified in the schedule to this certificate and the documents therein referred to.
- (8) DEKRA Certification B.V., certifies that this product has been found to comply with the Essential Health and Safety Requirements relating to the design and construction of products intended for use in potentially explosive atmospheres given in Annex II to Directive 2014/34/EU of the European Parliament and of the Council, dated 26 February 2014.

The examination and test results are recorded in confidential test report no. 219965400-2.
- (9) Compliance with the Essential Health and Safety Requirements has been assured by compliance with:
EN 60079-0 : 2009 EN 60079-11 : 2012

except in respect of those requirements listed at item 16 of the Schedule.
- (10) If the sign "X" is placed after the certificate number, it indicates that the product is subject to the Specific Conditions of Use specified in the schedule to this certificate.
- (11) This Type Examination Certificate relates only to the design and construction of the specified product and not to the manufacturing process and its monitoring.
- (12) The marking of the product shall include the following:



For marking see section 15.

Date of certification: 16 January 2017

DEKRA Certification B.V.

R. Schuller
Certification Manager

Page 1/7

Integral publication of this certificate and adjoining reports is allowed. This Certificate may only be reproduced in its entirety and without any charge.



BLISS ANAND



MJ Systems, LLC
Authorized Bliss Distributors
TX - Off (281) 842-7600
LA - Off (504) 264-7744
www.mjsusa.com • sales@mjsusa.com

Manufacturing Locations:

UNITED STATES OF AMERICA

3202 Industrial Blvd #804, Sugar
Land, TX 77478, USA
blissamericas.com

THE NETHERLANDS

Tijvoortsebaan 8Q,
5051 HJ Goirle,
The Netherlands
Ph.: +31 (0) 13 304 0111
e-mail: sales@blisseurope.eu

UNITED ARAB EMIRATES

P.O. Box: 18576, S40412A,
Jebel Ali Free Zone South,
Dubai, U.A.E.
Ph.: 00971-4-883 56 33
Fax: 00971-4-883 56 44
e-mail: reception.gesme@blissanand.com

KINGDOM OF SAUDI ARABIA

Production Unit #101, B-2,
Cluster 2, Modon Industrial City 3,
Zip code -34847, KSA-Dammam
Phone: +966 (0) 56 678 4945
e-mail: ksa@blissanandusa.com

INDIA

Plot No. 240, Sector-3,
Growth Center, HSIIDC,
Bawal, Haryana, India
Ph.: +91 (1284) 269400-99
Fax: +91 124 2290884
e-mail: sales@blissanand.com



UNITED STATES OF AMERICA | UNITED ARAB EMIRATES
INDIA | THE NETHERLANDS | KINGDOM OF SAUDI ARABIA

www.blissanand.com