

RHEONIK.

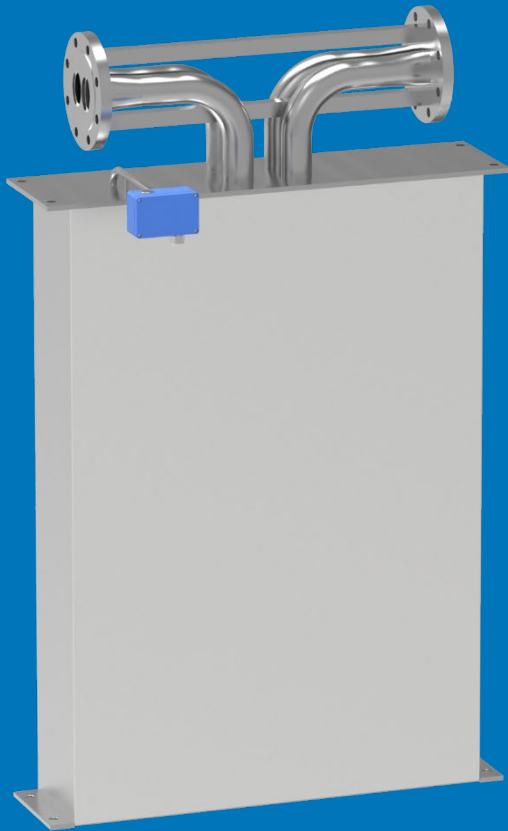

RHM 60

Coriolis Mass Flow Meter With uncompromising Performance

Terminal Transfer / Plant Balance / Asphalt, Bitumen and other High Temperature Fluids / Mixing and Batching / Reactor Charging / Barge, Ship, Rail Car and Truck Filing



MJ Systems, LLC
Authorized Rheonik Representatives
TX - Off (281) 842-7600
LA - Off (504) 264-7744
www.mjsusa.com • sales@mjsusa.com

GET FLOW MEASURED



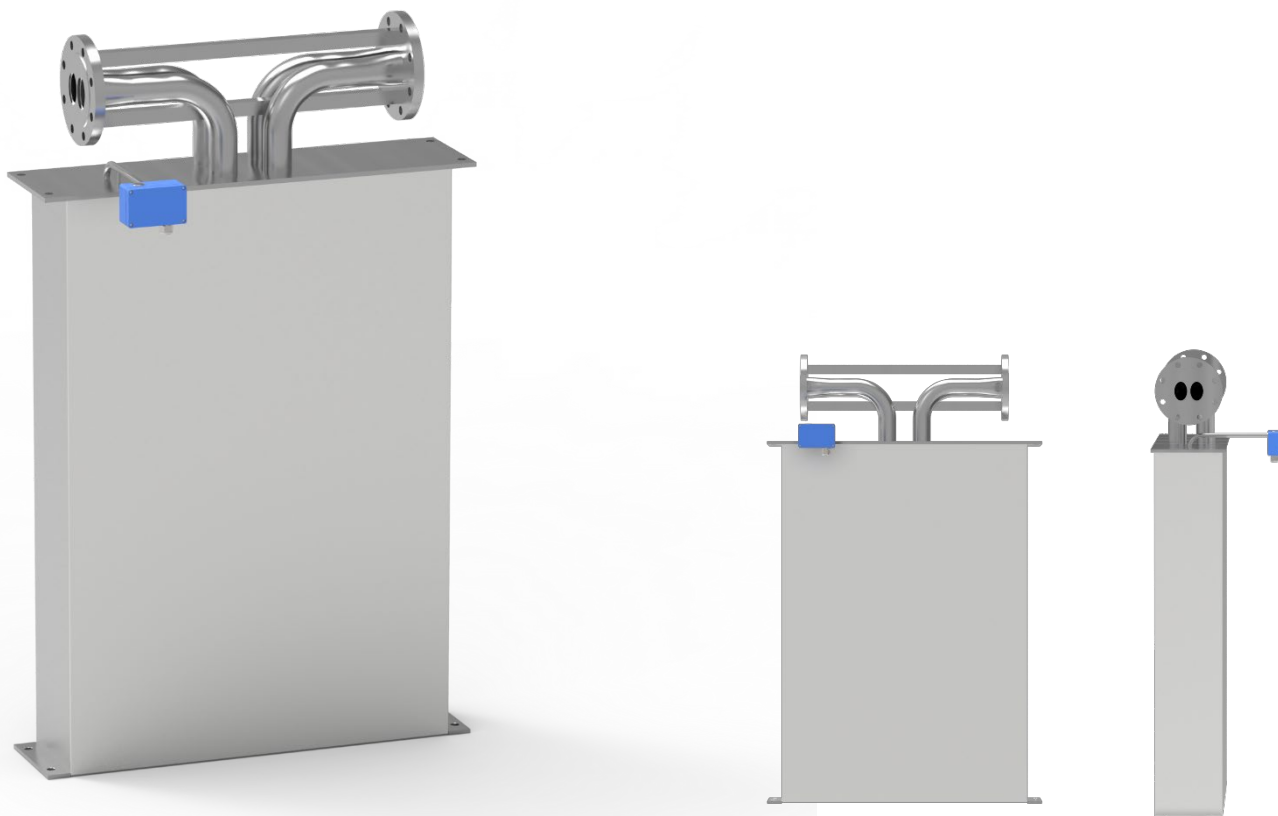

Features

- Typical measuring range up to 3000 kg/min (6613.87 lb/min)
- Pressure ratings up to 490 bar (7107 psi)
- Temperature ratings from -196 to +350 °C (-320 to +662 °F) – extended on request
- Mass flow uncertainty down to 0.1 %
- Repeatability down to 0.05 %
- 4 kHz measurement updates and response time of less than 10 ms when used with RHE 40 Series transmitters
- Accurately measure flow rates down to 30 kg/min
- The Rheonik **AnyPipeFit Commitment** provides custom process connection type and size flexibility on any meter to suit your existing plant, saving time and expense on installation costs
- Approved for use in hazardous areas
- SS 304 Stainless steel enclosure, SS 316 optional
- Integral and remote transmitter versions available

General Specification Overview

Nominal Flow (Q_{nom})*	2500 kg/min (5512 lb/min)
Maximum Flow (Q_{max})*	3000 kg/min (6614 lb/min)
Typical Minimum Flow (Q_{min})*	30 kg/min (66 lb/min)
Operating Temperature	Fluid temperature range options cover applications from -196°C to +350°C (-320°F to +662°F). For integral transmitter versions please refer to transmitter datasheet
Ambient Temperature	-50 °C to +80 °C (-60 °F to +180 °F) (standard)
Pressure Ratings	Up to 490 bar / 7107 psi - dependent upon material
Electrical Connection Sensor w/o Integral Transmitter	M20 x 1.5 standard cable entry for JM, SM terminal box versions Optional entries available : ½" NPT or M25 x 1.5 (only for SM) or ¾" NPT (only for SM) Max. cable length to remote RHE transmitter 100 m / 328 ft
Sensor Enclosure Materials	Stainless steel 304 (standard), SS 316 (optional) Coated aluminum terminal box, SS 316 terminal box (optional)
Enclosure Type	Protection class IP65, NEMA 4 (standard); IP66 / NEMA 4X (optional)
Wetted Materials	1.4571 (SS 316Ti), 1.4410 (SuperDuplex) - standard 2.4602 (Alloy C22) - consult Factory Additional/customer specific materials available upon request
Process Connections	Nearly any – the Rheonik AnyPipeFit Commitment . Consult factory for types/sizes not listed in this data sheet on the Mechanical Construction pages
Pressure Rating Compliance	Europe – PED: Module A2, Module B3.1+C2 Canada – CRN: Canadian Registration Number
Certifications and Approvals	ATEX / IECEx Approvals for Zone 0, 1 (details see page 10) North American Approvals Class I, Div. 1, 2, Gr. A,B,C,D, Zone 0, 1, 2 MID custody transfer approval (OIML R117) American Bureau of Shipping (ABS) Product Type Approval for use on marine vessels
Testing and Inspection	All sensors are hydro tested, calibrated and supplied with a traceable calibration certificate. Customized calibration and testing services are available
Project Documentation and QA, Services	Rheonik offers a full set of services for large and complex engineering projects. Typical services offered are, but not limited to: <ul style="list-style-type: none"> • Certificates of origin and conformity, mill certificates • Data books including WPAR, WQS, NDT, test & quality plans, functional testing, calibration procedures, customized packing, factory acceptance etc. • Painting to project specification • Start up and commissioning services on/offshore
Options	Enclosure heating for high temperature applications Cleaning for oxygen service , ... For more consult factory

* At Q_{nom} pressure drop across a parallel tube sensor will be approximately 0.5 bar (7 psi) for H2O. Sensors can be operated at higher flow rates up to Q_{max} but pressure drop will be higher. Typical Minimum Flow Q_{min} is the recommended lowest flow rate for an accurate measurement. Sensors will measure flow rates lower than Q_{min} but uncertainty will increase beyond 1% of rate.

The flow rate specifications above relate to standard pressure, parallel tube, manifold sensor versions. Models with higher pressure ratings have increased wall thickness and will have higher pressure drops.

Calibration Options

Standard and Premium Calibration

A	0.20 % Uncertainty <i>Requires RHE 20 Series transmitter. All others 0.5 %</i>
B	0.15 % Uncertainty <i>Requires RHE 20 Series transmitter or higher</i>

Premium Plus and Ultimate Calibration

G	0.10 % Uncertainty <i>Requires RHE 20 Series transmitter or higher</i>
----------	--

Low Flow and Customized Calibration

1	0.10 % Low Flow Focused Calibration* <i>Requires RHE 40 Series transmitter</i>
X	Customized Calibration** <i>Consult factory</i>

* Low flow calibration focuses on the range from $Q_{nom}/2$ downwards to lower flow rates than on other calibrations. Often used for low pressure gas or very viscous liquids
 ** Customized calibration uses specific calibration points according to customer requirements

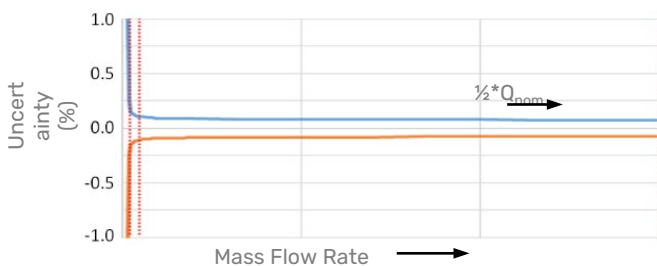

Uncertainties and flow measurement turn-down

The turn down capability from Q_{nom} of the flow sensor is driven mainly by its zero point stability. At the very low end of the measuring range the uncertainty (u) is dominated by the zero point stability. The zero stability of a standard sensor is: 0.30 kg/min (0.66 lbs/min). Zero point stability of a Gold Line sensor is 0.27 kg/min (0.60 lbs/min).

For flow $Q \geq ZP \text{ stability} / (\text{Base Calibration uncertainty}/100) \rightarrow u = \text{calibration uncertainty}$
 For flow $Q < ZP \text{ stability} / (\text{Base Calibration uncertainty}/100) \rightarrow u = (\text{zero stability}/Q) * 100$

Uncertainties from environmental and process conditions

- If sensors are not zeroed at operating conditions, minor additional uncertainties can arise from elevated temperatures and pressures: $\pm 0.000815 \%$ of maximum flow per $^{\circ}\text{C}$ and $\pm 0.001083 \%$ of maximum flow per bar.
- Process temperature effect on density: additional uncertainty of $\pm 0.000106 \text{ g/cm}^3$ per $^{\circ}\text{C}$ difference from calibration temperature with standard density calibration and of $\pm 0.000009 \text{ g/cm}^3$ per $^{\circ}\text{C}$ difference from calibration temperature with enhanced density calibration. This effect can be mitigated by a simple field density adjustment at operating conditions.
- Process pressure effect on mass flow: The effect of pressure on flow measurement is 0.053 % of rate per bar. Compensation is possible by pressure sensor input (analog input or digital write) or manual value entry into the transmitter.
- Process pressure effect on density: The effect of pressure on density measurement is 0.000024 g/cm^3 per bar. Compensation is possible by pressure sensor input (analog input or digital write) or manual value entry into the transmitter.

Premium Plus, Low Flow and Enhanced Density Calibration come with Gold Line sensors and are not available in all materials, pressure and temperature ranges.

Reference conditions: 18–24 °C Water @ 1–3 bar; Gas (Natural gas) 35–100 bar.

Density Calibration / Performance (Liquid)

N	No Live Density Calibration
S	Standard $\pm 0.001 \text{ kg/liter}$ Uncertainty
D	Enhanced $\pm 0.0005 \text{ kg/liter}$ Uncertainty

Flow Measurement Repeatability

Standard Sensors $\pm 0.1 \%$ of rate
 Gold Line Sensors $\pm 0.05 \%$ of rate

Temperature Measurement

Better than $\pm 1^{\circ}\text{C}$

Pressure Drop

Every Coriolis flow sensor generates pressure drop across its inlet and outlet when in use. The amount of pressure drop generated is mainly a function of the flow velocity within its tubes and the flowing viscosity of the stream.

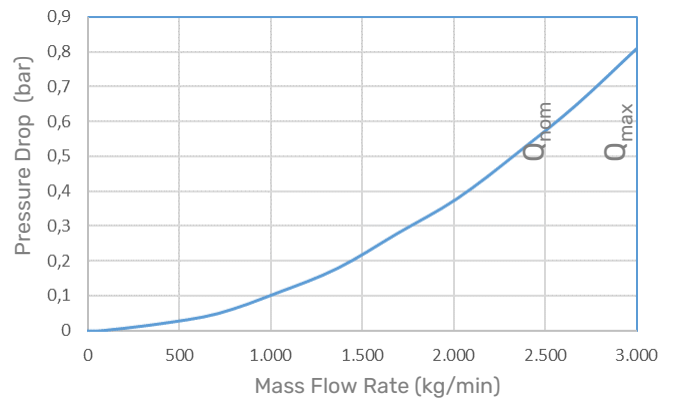

0 – 3000 kg/min water, sensor with P1 pressure rating. Higher viscosities create higher pressure drop

Measurement Tube Materials and Pressure Ratings

The maximum pressure (p_{max}) of a sensor is determined by its lowest rated part. The lowest rated part can be either the measurement tube (p_{max} see table to the right), the connection block/manifold (p_{max} indicated in the mechanical construction section) or the process connection (for p_{max} see published standards or manufacturer information).

Material	Pressure Code	50°C / 122°F	120°C / 248°F	210°C / 410°F	350°C / 662°F
SS 316Ti (standard)	P1	104 1508	93 1349	80 1160	67 972
SuperDuplex*	P2	258 3742	242 3510	210 3046	n/a
SuperDuplex*	P3	490 7107	430 6237	389 5642	n/a

* Note minimum operating temperature for SuperDuplex stainless steel is -40 °C

Units: bar / psi

Other Materials

Other wetted materials may be possible for chemical compatibility, lower pressure drop, abrasion allowance, other application specific requirements. Rheonik can provide nearly any material for the wetted parts.
Contact factory with specification for assessment and availability.

Mechanical Construction

Sensors are manufactured with two internal measurement tubes arranged side by side. In parallel or dual path sensors, these tubes are connected in parallel and the flowing fluid is split equally between them. In sealless designs, the measurement tubes are continuous between the process connections and do not have seals.

Sealless design with flange connections

PFO: parallel / dual path

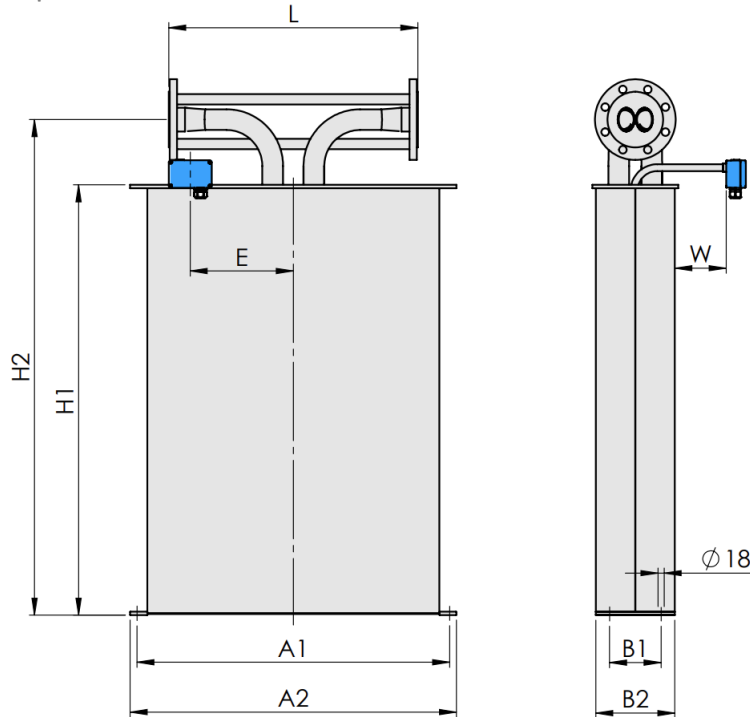

Process Connection PFO	Dim. L mm / in	Order Code
Flange ANSI 4" 150# RF/SF	PFO 725 / 28.54	A1
Flange ANSI 4" 300# RF/SF	PFO 725 / 28.54	A2
Flange ANSI 4" 600# RF/SF	PFO 725 / 28.54	A3
Flange ANSI 4" 900# RTJ	PFO 900 / 35.43	R6
Flange ANSI 4" 1500# RTJ	PFO 900 / 35.43	R1
Flange ANSI 4" 2500# RTJ	PFO 900 / 35.43	R2
Flange DIN DN100/PN40 Form B1	PFO 725 / 28.54	D1
Flange DIN DN100/PN100 Form B2	PFO 725 / 28.54	D2

PFO Dimensions	mm	in
A1	910	35.83
A2	950	37.40
B1	150	5.91
B2	230	9.06
H1	1253	49.33
H2	1443	56.81
E	300	11.81
W	150	5.91

Weights and Shipping Dimensions

- Approx. weight with 4" 150# flanges: 235 kg / 518 lb
- Shipping in wooden crate as per ISPM 15, approx. 180 x 120 x 75 cm (71 x 48 x 30 in)
- Gross weight with 4" 150# flanges and RHE28 transmitter approx. 310 kg / 683 lb

Note

All dimensions are for standard products. For customization of face to face length and/or process connection types other than the ones listed on this page, please consult factory. Note that larger diameter flange process connections are always possible.

Transmitter Range

Any Rheonik Mass Flow Transmitter model can be combined with any Rheonik Mass Flow Sensor to provide an overall mass flow measurement system to suit any requirement. Rheonik Coriolis Transmitters are available in versions specifically designed for process, industrial and OEM applications. Economical blind front versions of some transmitters are available where displays and keypads are not required. The wide range of sensors and transmitters provide tremendous options for system designers and end users alike.

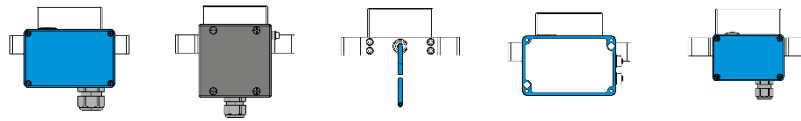

Product Code	JM	SM	TM	J5	PM
 RHE 21	✓	✓	✓	-	✓
 RHE 26	✓	✓	✓	-	✓
 RHE 27	✓	✓	✓	-	✓
 RHE 28	✓	✓	✓	-	✓
 RHE 42	✓	✓	✓	-	✓
 RHE 45	-	-	-	✓	-

Options and Manufacturing Instruction Codes

Options Codes	
NN	Without Option
H1	Heating for Housing, Steam - Connection DN25 PN40
H2	Heating for Housing, Steam - Connection 1" ANSI 150 RF
H3	Heating for Housing, Steam - Connection 1" ANSI 300 RF
SB	Housing and base plate in SS 316 - check with factory for lead time
T1	Terminal box with cable entry upwards/gas installation
P2	Housing purge NPT ½" (2 pcs)

NOTE: when specifying a sensor with multiple part code options (i.e. P2 and SB), separate each code with a comma in the part string (i.e. ...P2,SB...)

Instructions	
N	No manufacturing instructions
O	Special Cleaning, fat free
S	Sea-worthy packing

Additional separate choices

Options	Order Code ORHM-...
E1	Terminal box prepared for ½" NPT cable entry
E2	Terminal box prepared for M25 x 1.5 cable entry - only with electrical connection SM
E3	Terminal box prepared for ¾" NPT cable entry - only with electrical connection SM
TP	Separate TAG Plate in Stainless Steel (TAG Information only)
TP-C	Type Label in Stainless Steel (TAG and all other label information)

Standard cable entry on JM, SM terminal box is M20 x 1.5. Cable entry on PM terminal box is always M16 x 1.5

Hazardous Area Certifications

Code	Zone / Division	Approval	Labeling
A0	Zone 0	ATEX	II 1G Ex ia IIC T6...T1 Ga
A1	Zone 1	ATEX	II 2G Ex ib IIC T6...T1 Gb
AB	Zone 0	ATEX	II 1G Ex ia IIB T6...T1 Ga
AB	Zone 1	ATEX	II 2G Ex ib IIB T6...T1 Gb
A2	Zone 2	ATEX	II 3G Ex ec IIC T6...T1 Gc
A0	Zone 0	IECEX	Ex ia IIC T6...T1 Ga
A1	Zone 1	IECEX	Ex ib IIC T6...T1 Gb
A2	Zone 2	IECEX	Ex ec IIC T6...T1 Gc
C0	Div 1, Zone 0	Zone USA/Kanada	Class I, Div 1, Groups A, B, C and D T6...T1; Class I, Zone 0, AEx ia IIC T6...T1 Ga
CB	Div 1, Zone 0	Zone USA/Kanada	Class I, Div 1, Groups C and D T6...T1; Class I, Zone 0, AEx ia IIB T6...T1 Ga
C2	Zone 2	Zone USA/Kanada	Class I, Zone 2, AEx nA IIC T6...T1 Gc





About Rheonik

Rheonik has but one single purpose: to design and manufacture the very best Coriolis meters available.

Our research and engineering resources are dedicated to finding new and better ways to provide cost effective accurate mass flow solutions that provide value to our customers. Our manufacturing group care for each and every meter we produce from raw materials all the way to shipping, and our service and support group are available to help you specify, integrate, start-up and maintain every Rheonik meter you have in service. Whether you own just one meter or have hundreds, you will never be just another customer to us. You are our valued business partner.

Need a specific configuration for your plant? Don't compromise with a "standard" product from elsewhere that will add extra cost to your installation. If we can't configure it from our extensive and versatile product range, our exclusive **AnyPipeFit Commitment** can have your flow sensor customized with any size/type of process connection and face to face dimension you need.

No matter what control system you use as the backbone in your enterprise, with our **AnyInterface Commitment**, you can be sure that connection and communication will not be a problem. Alongside a wide variety of discrete analog and digital signal connections, we can also provide just about any network/bus interface available (for example: HART, ProfibusDP, ProfiNet, EtherCAT, PowerLink, EtherNet/IP, CAN,) with our RHE 40 Series family of transmitters. Rheonik RHE 40 Series transmitters can connect to your system – no headache and no conversion needed.



MJ Systems, LLC
Authorized Rheonik Representatives
TX - Off (281) 842-7600
LA - Off (504) 264-7744
www.mjsusa.com • sales@mjsusa.com

