

RHEONIK.



RHE 21

Ex d / Ex d e Extreme Environment Multifunction Mass Flow Transmitter

General and critical process flows / Feed stocks and transfers /
Custody transfer / Well head production / Offshore



MJ Systems, LLC
Authorized Rheonik Representatives
TX - Off (281) 842-7600
LA - Off (504) 264-7744
www.mjsusa.com • sales@mjsusa.com

GET FLOW MEASURED





Features

- Wall or Pipe Bracket Mounting
- Corrosion resistant housing in SS316 available
- Selectable Units for Mass, Volume, Density and Temperature
- Positive, negative and net totalizers for both volume and mass flow
- Two configurable pulse/frequency/status outputs – double pulse available
- Two analog outputs
- Two configurable digital status outputs
- Outputs are also available as intrinsically safe version
- Configurable digital input
- Analog input configurable for pressure or density
- Advanced functions: Net Oil, Baume/Brix, % Solids, Standard Density and Standard Volume (API MPMS Ch. 11)
- Modbus RTU and HART
- Custody transfer lockout switch and seal point
- Backlit Color LCD display and 3 behind-glass buttons with intuitive menu design
- USB connection for PC running Rheonik RHECom software
- Built-in Assurance View® Advanced Diagnostic Set – clear publication of measurement status with Assurance Factor® and/or color changing display
- Password Protected Setup
- Upload and download of configuration files
- Power consumption typical 3-4 W

General Specification Overview

Enclosure Material	Stainless steel. Optionally all 316 stainless steel
Enclosure Rating	IP66 / NEMA 4X
Ambient Temperature	-40 to +60°C / -40 to +140°F (reduced visibility below -20°C / -4°F)
Dimensions	Depending upon construction type, please see Dimensions page (approx. 255 x 200 x 100 mm / 10 x 8 x 4 in)
Display	Backlit color LCD. Screen changes color to indicate warning or error
Weight	8 kg (17.5 lb)
Operation	3 x behind-window capacitive buttons for menu navigation / settings
Sensor Connection	Integral sensor cable with 3m or 10m length or optional IS terminal box for separate custom length sensor cable connection
Analog Outputs	Up to 2 x 4-20mA outputs, active or passive Intrinsically safe versions available Uncertainty of analog outputs +/- 0.1% of reading, +/- 10µA
Digital Outputs	Up to 2 x configurable status outputs (IEC60946) Intrinsically safe versions available
Pulse/Freq/Status Outputs	Up to 2 x configurable pulse/frequency/status outputs (IEC60946), max 10 kHz
Digital Inputs	Up to 2 x configurable control inputs (IEC60946)
Analog Input (optional)	1 x 4 - 20 mA analog input (active) for two-wire external sensor
Digital Data Communications	Modbus RTU (RS485); Connection to PC (USB) with Rheonik RHECom software HART over analog output
Power Supply	100-240 VAC (48 to 62 Hz), 5W and/or 12-24 VDC +/- 10%, 4W
Cable Entries for Power and I/O:	Type E* two M16 x 1.5 entries with Ex e glands 4-11mm (standard) Type E3, E4, E5, EP optional ½" NPT, ¾" NPT, M20 x 1.5, M25 x 1.5 Type H* two ½" NPT
Hazardous Area Approvals	For ATEX / IEC Ex and cCSAus please see Part Number Code page Others available on request

Hazardous Area Installation Overview



Sensor and transmitter must have matching approvals

Software Function Packages and Features

Standard Operation Package (Part Number Code S0)

The RHE21 Standard Operation Package provides the following measurement and function features:

Direct Mass Flow Measurement

Mass flow is calculated using the Coriolis principle to provide a high accuracy Mass Flow measurement of the fluid flowing through an Omega Tube Coriolis Meter.

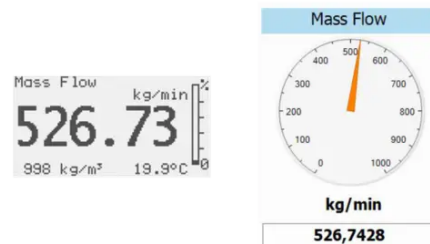

Temperature Measurement

Each Omega Tube Coriolis Sensor provides a temperature measurement from built in sensors.

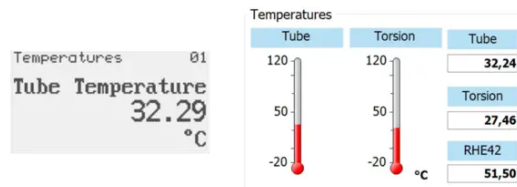

Fixed and Calculated Density Function

The Fixed Density function allows to enter a fixed density value for volumetric flow calculations.

The Calculated Density function allows density to be generated based upon process temperature. A base/reference density at a known temperature is entered for the fluid being measured along with a coefficient describing the change in density per temperature unit. The firmware in the transmitter calculates flowing density based upon this information to use for volumetric flow calculations.

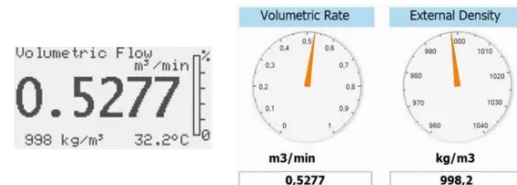

Calculated Actual Volume Measurement for Liquids and Gas

Volume measurement is calculated by dividing direct mass flow measurement by the Fixed Density.

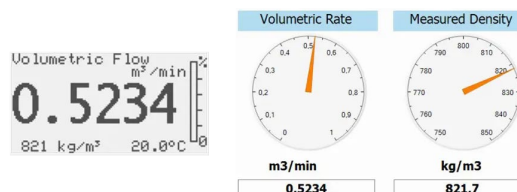

Standardized/Normalized Volume Measurement for Gas

This function calculates the volume of gas passing through the meter at standard conditions. The density of the gas at standard conditions is entered into the transmitter and the volume is calculated using this in conjunction with the flowing mass.

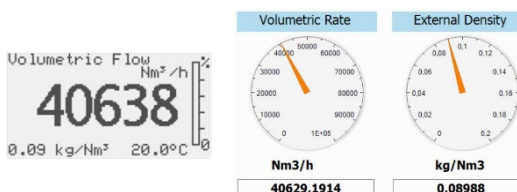

Standard Package (Part Number Code S0) continue

Password Protection

All setup and calibration parameters within the meter are protected with passwords to prevent unintentional or unauthorized change once installed.



Batch Controller

The transmitter is equipped with an onboard batch controller that, in conjunction with external pumps and/or valves allows the precise delivery of a preset mass or volume of process fluid on demand. Operated from the instrument front panel, remotely via operator switches or through digital communication from a connected supervisory control system, the controller is configured to utilize either a one stage or a two stage delivery strategy in ensuring the right amount of fluid is batched through the meter. The electronics self-learns, adjusting shut off times as more and more batches are delivered to further refine the amount of delivery, saving material costs and improving quality.



Assurance View® Diagnostics

Inbuilt self-monitoring functions are available that can be used to determine the reliability of the flow meter readings at all times. Diagnostics are quickly accessed through dedicated menu displays, RHECom software and the MODBUS interface.



Density Operation Package (Part Number Code D0)

The RHE21 Density Operation Package includes all features from the Standard Operation Package plus the following measurement and function features:

Direct Density and Volume Measurement

The flowing density of the fluid in an Omega Tube Coriolis Sensor is determined from the measured resonant frequency of the sensor and used to calculate instantaneous volumetric flowrate.



Density Package (Part Number Code D0) continue

Brix/Baume Units

The unit can be configured to read out in °Brix or Baume. °Brix or Baume are used extensively in the sugar and beverage industries.



Assurance Factor Package with Assurance Diagnostics Suite (Part Number Code AF)

The RHE21 Assurance Factor Package includes all features from the Density Operation Package plus the following advanced diagnostic functions:

Assurance Factor®

Assurance Factor® is a numeric value generated by an internal algorithm that indicates the overall health of the flow meter and measurement. Assurance Factor® value can be used to trigger changes in screen color when the optional display is fitted to the RHE21 (White – Amber – Blue – Red), providing highly visible wide area condition indication.



WHITE

Normal Operation

No faults present. All parameters within expected limits. Meter fully operational



AMBER

Operation Not Optimal

Sensor subject to noise / changing conditions in pipe. Measurement quality may be compromised



BLUE

Operation at Limit

Sensor experiencing disturbance. Measurement quality compromised

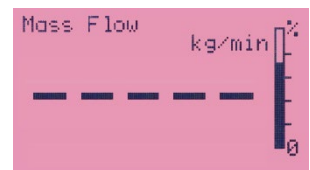

RED

Measurement Failure

Sensor experiencing extreme disturbance / meter in fault. Measurement offline

Oil and Gas Function Package (Part Number Code GV)

The Oil and Gas Function Package includes all features from the Assurance Factor Package plus the following advanced measurement applications:

API Standard Density/Volume

When configured for this application, the transmitter will calculate density at standard conditions to API MPMS Chapter 11. All three product groups – crude oil, refined products and lubricants – can be metered using this built-in application. Precise calculation requires temperature and pressure inputs. Both inputs can be supplied through manual user menu entries or through Modbus updates to the transmitter or the internal tube temperature of the sensor. Volume flow and totalization at standard conditions are generated using the calculated standard density value.

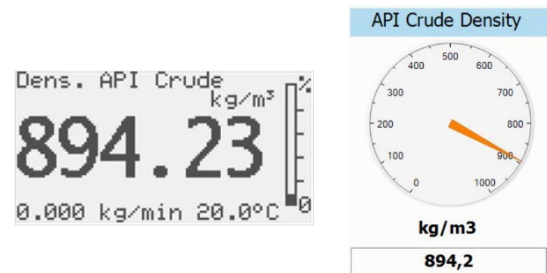

Net Oil Calculation

Crude Oil is often a mixture of oil and water and it is desirable to know the actual oil content. With this function, it is possible to calculate the net oil amount in a flowing stream using a live density measurement. The standard density (at standard temperature and pressure) of both the crude oil and the water/other portions of the stream must be provided as inputs for the calculation. These can be entered manually through the transmitter’s user menu or digitally via Modbus.

NET OIL



Percent Concentration Calculation

Percent concentration of a fluid in a mixture of two fluids (i.e. alcohol in water) or solids in liquid can be determined using the percent concentration function. With this function, the density of both components in the stream must be provided as inputs for the calculation. These values are entered manually through the transmitter’s user menu or digitally via Modbus and should be updated as temperature conditions change to obtain the best performance.

Data View/Monitoring			
Address	Name	Value	Unit
0x480C	VolPercentMainSubstance	53,96152	%

Fluid Transfer Package (Part Number Code CT)

The Fluid Transfer or Custody Transfer Package includes everything from the Oil and Gas Function Package plus the following features:

Precision Flow Analysis (PFA)

For fast fill applications down to 0.5s duration measurements, transmitter update time can be increased to 4ms. This allows a 250Hz totalizer update rate (50Hz is standard) to maintain very fast tracking of actual volume/mass delivered, and e.g. through the internal batch control function, results in a maximum signal delay of 10-20ms to a connected control valve once the batch set-point is reached. Depending upon the speed of operation of the fill valve, repeatable accuracies of better 1% are achievable for filling operations of 500ms duration and less.



Hardware Lock Switch

For applications such as custody transfer where sealing is required. This switch, when engaged, prevents change of any setting within the transmitter through both the user panel interface and through a digital communications port. To accommodate some special customer needs the Lock Switch configured to leave a totalizer reset and/or a zero calibration possible.

Once the Lock Switch is set, a tamperproof seal can be applied to the transmitter case to indicate if the transmitter has not been opened since sealing.



Power Supply Options

The RHE21 can be configured with one of three power supply options:

- Universal AC Power - 100-240 VAC $\pm 10\%$ (48 to 62 Hz) (Part Number Code A1)
- Wide Tolerance DC Power - 12-24 VDC $\pm 10\%$, 4W (Part Number Code D1)
- Dual Supply - 100-240 VAC $\pm 10\%$ (48 to 62 Hz) / 12-24 VDC $\pm 10\%$, 4W (Part Number Code U1)
This unique option provides inputs for simultaneous connection of both a universal AC and separate DC supply. The transmitter utilizes AC power when available but will switch to the DC supply in the event of AC power outage. The DC supply can be a battery source. As an example, an RHE27 transmitter and connected sensor will operate for 10 days or more on a typical automobile battery.

Program Package Function Summary

Feature	Program Package Code				
	SO	DO	AF	GV	CT
Live Mass Flow Measurement	X	X	X	X	X
Live Temperature Measurement	X	X	X	X	X
Inferred Density by Reference Density and Temp.	X	X	X	X	X
Fixed or Norm Density Value (e.g. kg/Nm ³)	X	X	X	X	X
Volumetric Flow from Inferred/ Fixed/Norm Density	X	X	X	X	X
Standardized Gas Volume Calculation	X	X	X	X	X
Resettable Mass / Volume Totalizers	X	X	X	X	X
Non-Resettable Mass / Volume Totalizers	X	X	X	X	X
Single and Two Stage Batch Control	X	X	X	X	X
Self Learning Batch Control	X	X	X	X	X
Assurance View® Diagnostics	X	X	X	X	X
Setup/Configuration Password Protection	X	X	X	X	X
Live Density Measurement		X	X	X	X
Volume using Mass and Measured Density		X	X	X	X
Brix / Baume Units		X	X	X	X
Assurance Factor® Calculation and Diagnostics			X	X	X
PID Controller for Analog Output (e.g. Pump, Valve)			X	X	X
Partly Filled Pipe Management			X	X	X
API Standard Density/Volume				X	X
Net Oil Calculation				X	X
Concentration/Percent Substance Calculation				X	X
Hardware Lock Switch					X

RHECom Software

The RHE21 transmitter is a fully featured device with many sophisticated functions and configuration is necessary for proper performance of these functions. RHECom software is available in three versions – Free, Pro and Pro+.

RHEComFree is available for download at no extra cost or on USB flash drive. RHEComFree allows full setup of transmitter parameters and includes a useful datalogging function for monitoring performance of the meter.

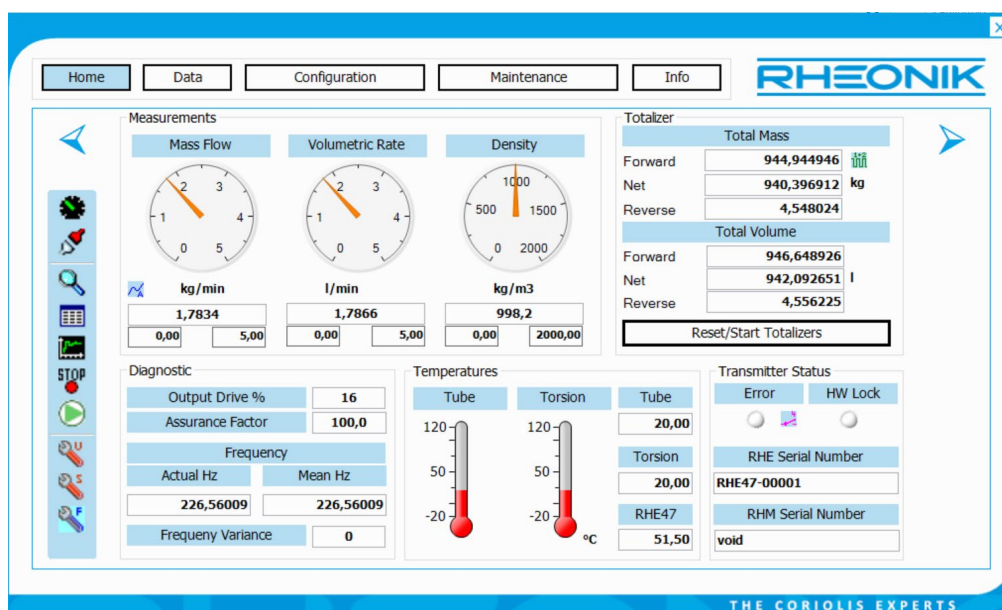

For a small one-time license fee, RHEComPro and RHEComPro+ offer additional insight and setup convenience menus. RHEComPro includes data logging, trending and broad diagnostic capabilities.

RHEComPro+ takes flow meter management one step further with a revolutionary fully functioning simulator application. With the simulator, you can trial run your application from the convenience of your office, adjusting transmitter settings, setting alarms and filters, and creating transmitter configuration files for upload into the actual unit. The simulator is also ideal for training - it exactly mimics the front panel of the instrument display and buttons when clicked and includes controls for adjusting flow, density and temperature readings just like the unit was in line!

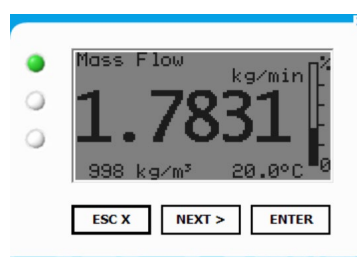
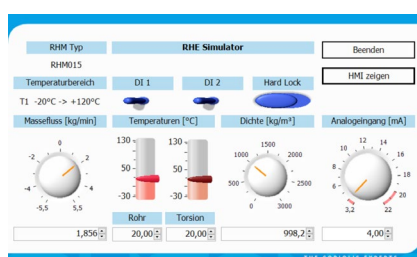

RHECom software is designed to ensure simple and expedient setup of Rheonik transmitter features and functions – a real time saver and a valuable tool.

Mechanical Construction

RHE21 Dimensions Type E1, E2

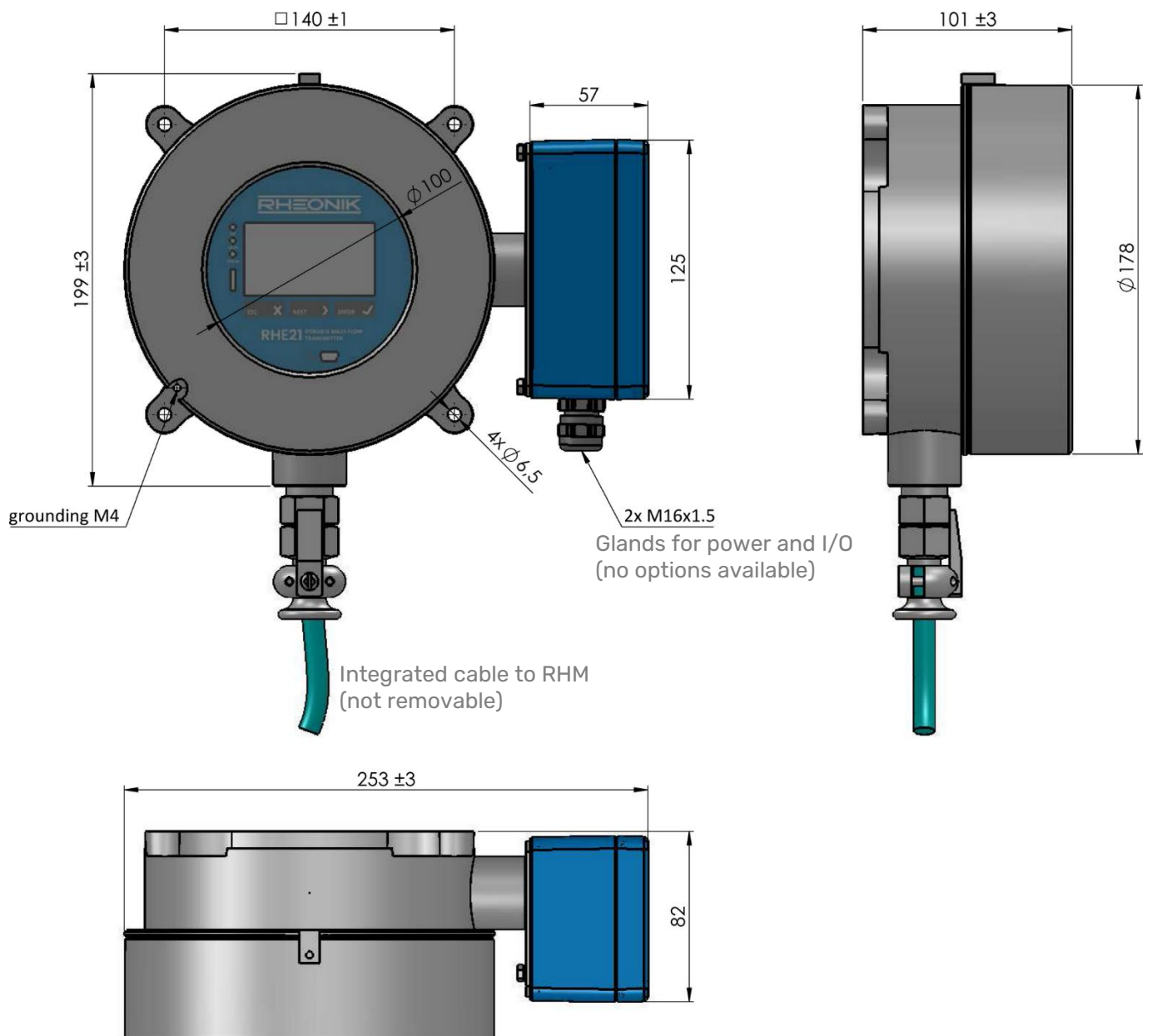

All dimensions in mm

Mechanical Construction

RHE21 Dimensions Type E3, E4

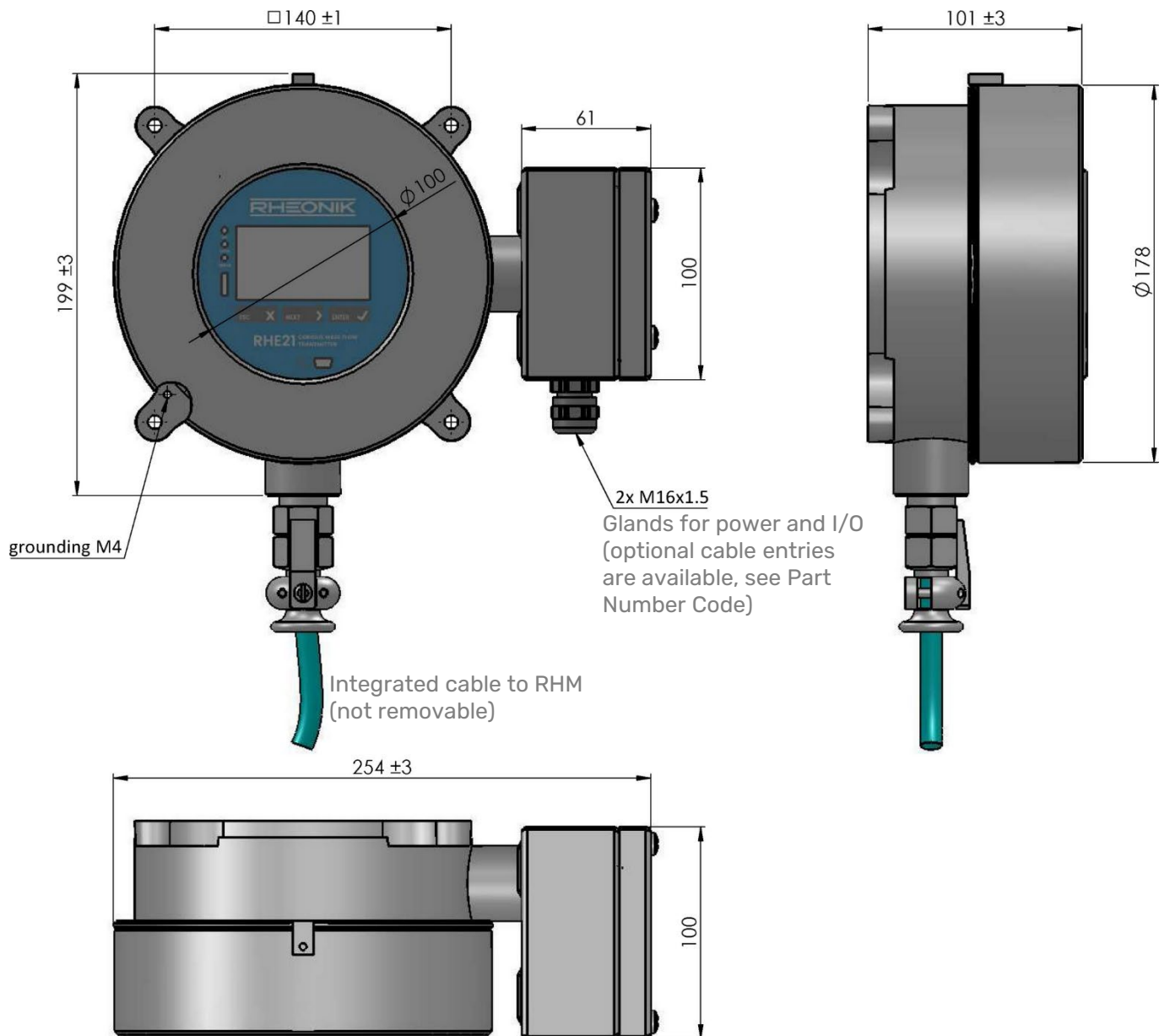

All dimensions in mm

Mechanical Construction

RHE21 Dimensions Type EP

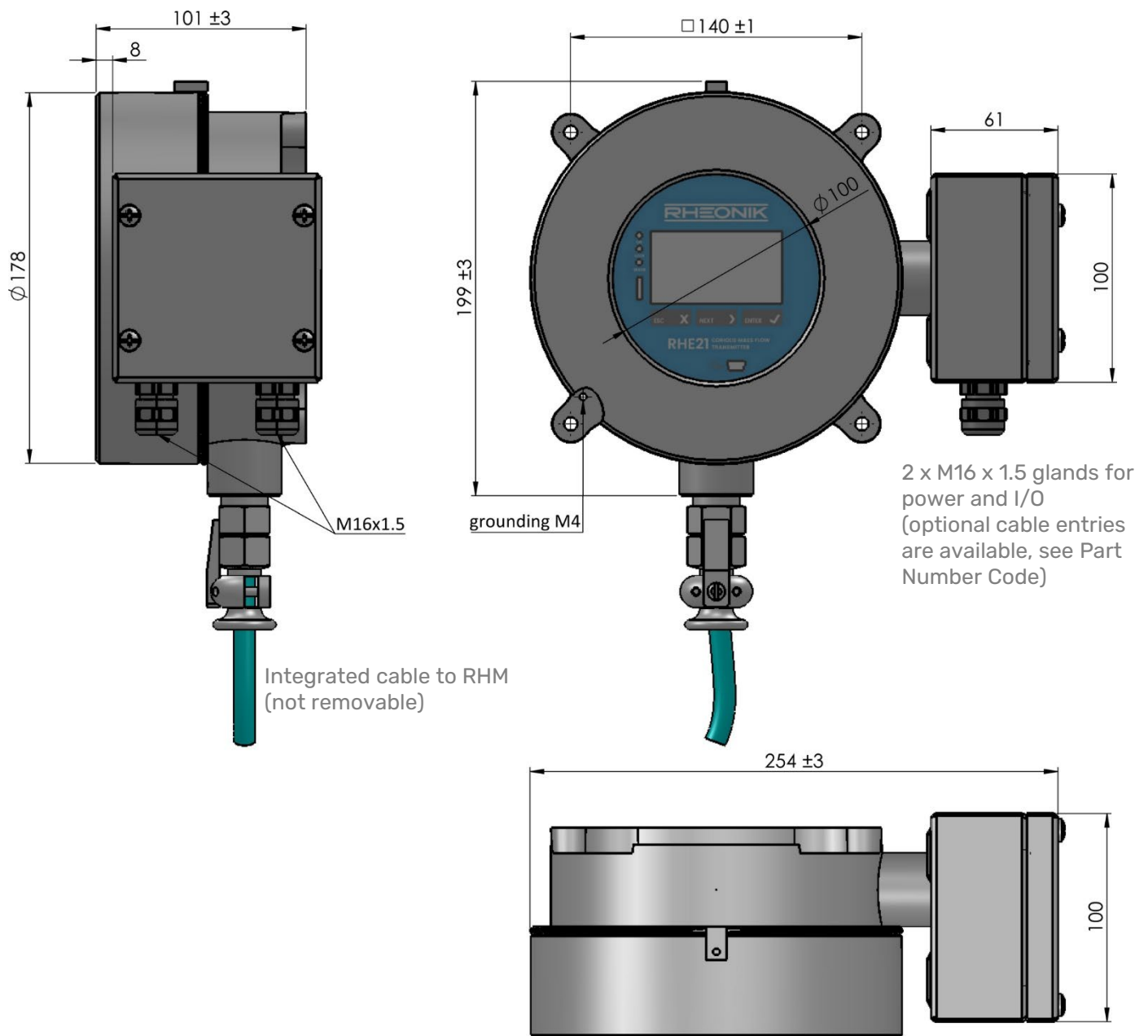

All dimensions in mm

Type EP for panel mount: 8 mm recessed I/O terminal box to fit RHE21 display front into panel window

Mechanical Construction

RHE21 Dimensions Type E5

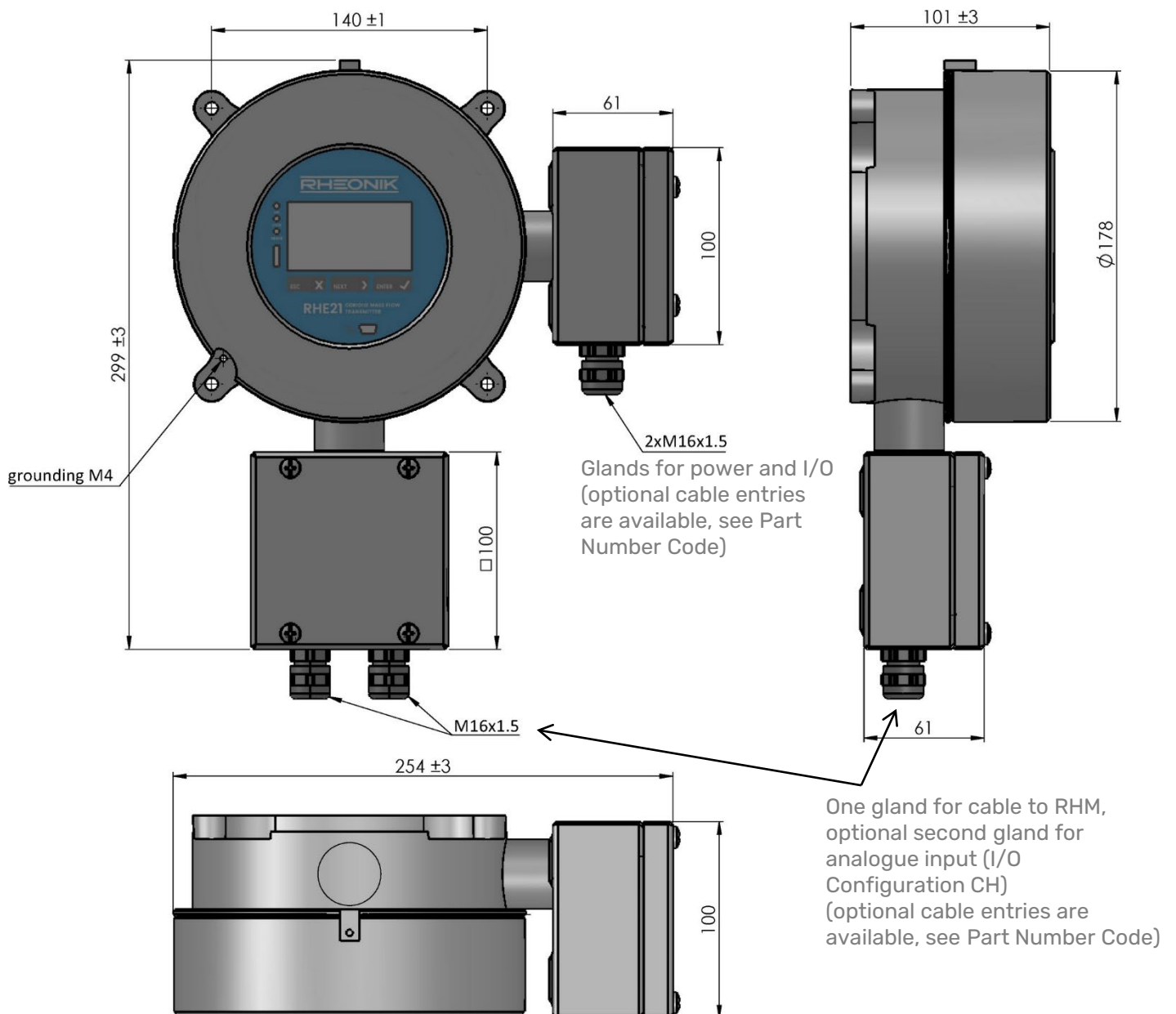

All dimensions in mm

Mechanical Construction

RHE21 Dimensions Type H1, H2

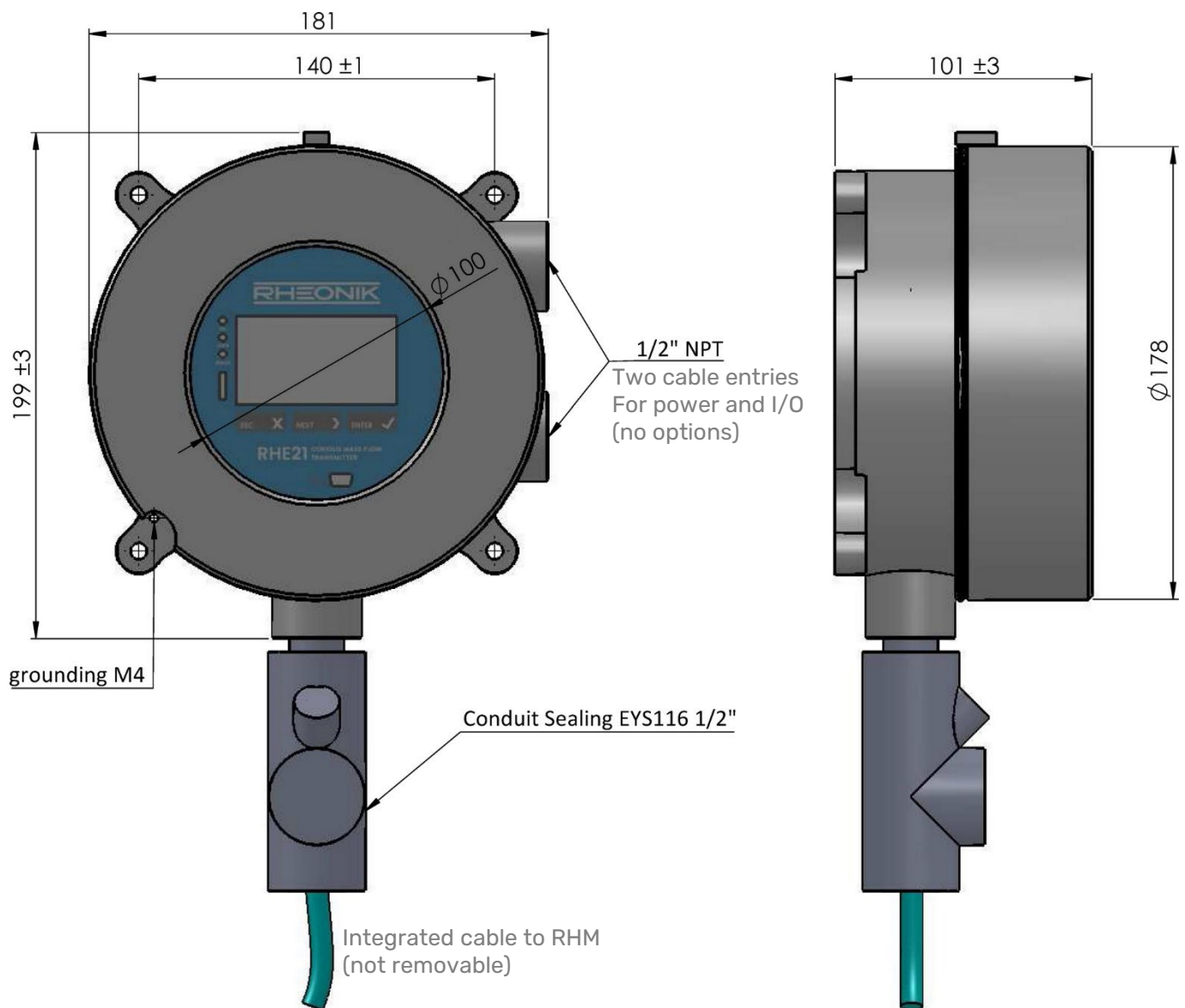

All dimensions in mm

Drawing shows CSA version. ATEX/IECEx version has the same RHM connection part as Type E1, E2, E3, E4

Mechanical Construction

RHE21 Dimensions Type H3

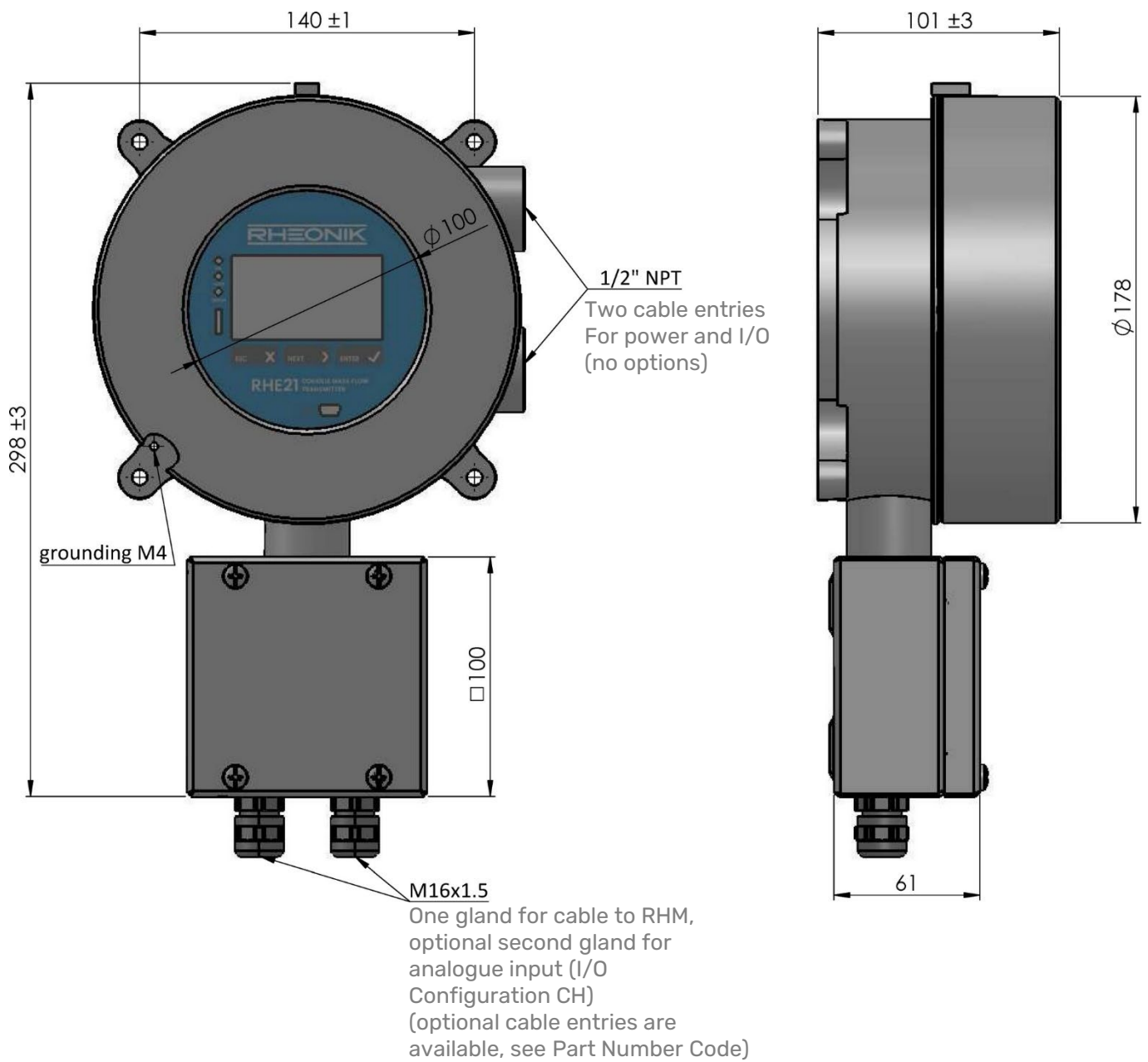

All dimensions in mm

Transmitter Range

Any Rheonik Mass Flow Transmitter model can be combined with any Rheonik Mass Flow Sensor to provide an overall mass flow measurement system to suit any requirement. Rheonik Coriolis Transmitters are available in versions specifically designed for process, industrial and OEM applications. Economical blind front versions of some transmitters are available where displays and keypads are not required. The wide range of sensors and transmitters provide tremendous options for system designers and end users alike.

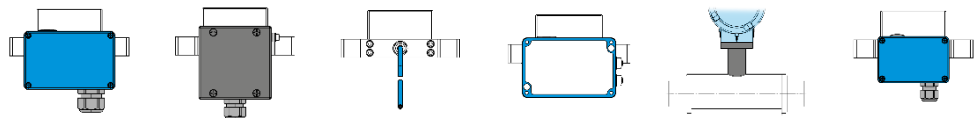

Product Code	JM	SM	TM	J5	C2	PM
 RHE 21	✓	✓	✓	-	-	✓
 RHE 26	✓	✓	✓	-	-	✓
 RHE 27	✓	✓	✓	-	-	✓
 RHE 28	✓	✓	✓	-	-	✓
 RHE 42	✓	✓	✓	-	✓	✓
 RHE 45	-	-	-	✓	-	-

RHE 21 Part Number Code

Construction Type

- E3 SS316 enclosure Exd(e), wall/hook, 1* SS316 terminal box, 3m sensor cable
- E4 SS316 enclosure Exd(e), wall/hook, 1* SS316 terminal box, 10m sensor cable
- EP SS316 enclosure Exd(e), panel mount, 1* SS316 terminal box, 10m sensor cable
- E5 SS316 enclosure Exd(e), wall/hook, 2* SS316 terminal box
- H1 Stainless steel enclosure Exd, wall/hook, 2* cable entry for I/O, 3m sensor cable
- H2 Stainless steel enclosure Exd, wall/hook, 2* cable entry for I/O, 10m sensor cable
- H3 SS316 enclosure Exd, wall/hook, 2* cable entry for I/O, 1* SS316 terminal box

Supply Voltage

- D1 12 to 24 VDC (+/- 10%)
- A1 100 to 240 VAC (48 to 62 Hz)
- U1 12 to 24 VDC (+/- 10%) and/or 100 to 240 VAC (48 to 62 Hz) - only H1, H2, H3

Software Function Package

- SO Standard OP system - mass flow, normalized density / volume
- DO Enhanced OP system - mass flow, measured density / volume - requires RHM density calib.
- AF Enhanced OP system plus Assurance Factor® Function (AF)
- GV Enhanced OP system plus AF and API std. Vol. and Net Oil (add CH for all functions)
- CT Enhanced OP system as GV plus hardware lock switch function

I/O Configuration

- S1 Standard One - 1*4/20mA (a), 2*DO (Pulse/Freq/Status), 1*DI, RS485 (Modbus)
 - S2 Standard Two - 2*4/20mA (a), 1*DO (Pulse/Freq/Status), 1*DI, RS485 (Modbus)
 - P1 Standard One - 1*4/20mA (p), 2*DO (Pulse/Freq/Status), 1*DI, RS485 (Modbus)
 - P2 Standard Two - 2*4/20mA (p), 1*DO (Pulse/Freq/Status), 1*DI, RS485 (Modbus)
 - SH HART - as Standard Two S2 plus HART
 - PH HART - as Standard Two P2 plus HART
 - CH Premium - as Standard Two P2 plus HART and analogue input. Only with type E5, H3
- Intrinsically safe output options - only with Type E* and 24VDC Supply D1**
- i1 One - 1*4/20mA (p, is), 2*DO (Pulse/Freq/Status, is), RS485 (Modbus, non-is)
 - i2 Two - 2*4/20mA (p, is), 1*DO (Pulse/Freq/Status, is), RS485 (Modbus, non-is)
 - i3 HART - as One i1 plus HART
 - iH HART - as Two i2 plus HART

Hazardous Area Approval (details see page 20)

- NN Without - RHM and RHE in ordinary locations
- AS ATEX/IECEX approval Ex II (1)G [Ex ia Ga] IIC (RHE in ordinary locations)
- A2 ATEX/IECEX Ex II 3(1)G Ex db ec [ia Ga] IIC T4 Gc - RHE type E* in zone 2
- A1 ATEX/IECEX Ex II 2(1)G Ex db eb [ia Ga] IIC T4 Gb - RHE type E* in zone 1
- C5 cCSAus Class I, Associated Equip. [Ex ia Ga] (RHE in ordinary locations) - only type H*D1
- C2 cCSAus Class I, Div. 2, Groups A,B,C,D (RHE in division 2) - only type H*D1
- C1 cCSAus Class I, Div. 1, Groups A,B,C,D (RHE in division 1) - only type H*D1

Performance Certifications

- NN Without
- MH OIML R137 approval incl. special labelling and docu. - requires hardware lock switch
- R9 OIML R139 approval incl. special labelling and docu. - requires hardware lock switch

Transmitter Options

- NNN None / all standard
- N67 Enhanced enclosure dual rating IP66/67 NEMA 4X/6, ambient -40°C to +65°C (caution with display - temp. restr.)
- NNH Hardware lock switch function (included in CT Software Function Package)
- 6NN SS316 enclosure for Construction Types H1, H2



Options and Accessories

Part Number	Description
	Construction Type E1, E2 (aluminum terminal box) - only with two M16 glands Ex e (no options available) Construction Type E3, E4, EP, E5, H3 (SS316 terminal box) - M16 glands Ex e, others optional Construction Type H1, H2, H3 - power supply and I/O only via 1/2" NPT cable entries
ORHE21-E1	Optional 1/2" NPT cable entries instead of M16 glands - only for SS316 terminal boxes
ORHE21-E2	Optional M20 x 1.5 cable entries instead of M16 glands - only for SS316 terminal boxes
ORHE21-E3	Optional 3/4" NPT cable entries instead of M16 glands - only for SS316 terminal boxes
ORHE21-E4	Optional M25 x 1.5 cable entries instead of M16 glands - only for SS316 terminal boxes
ORHE-SI	Pre-setting of pulse, analog outputs according to setting instructions.
ARHE42-H	Bracket for pipe mounting (max.D=50mm / 2") in stainless steel
ARHE42-H-316	Bracket for pipe mounting (max.D=50mm / 2") in SS316
ARHE21/42-SF	Sunshade for RHE21/42

General Options

Part Number	Description
ARHE-SO	USB flash drive with PC software RHEComFree, operation manual, calibration certificate(s), csv configuration file(s). One USB drive per order is sufficient. For RHE16/2X/4X
ARHE-PW	DIN Rail Power Supply Module 85 to 250 V to 24 VDC / 15 W (Non Ex) for RHE16/26/27/42
ARHE-MO	Modbus RS485 terminals to PC USB Converter for RHE16/2X/4X
ARHE-PR	PC Software RHEComPRO license key (upgrade for two years are included)
ARHE-PP	PC Software RHEComPRO+ license key (upgrade for two years are included)
ORHE-TP	Plate with TAG number in Stainless Steel (other labelling standard)
ORHE-TP-C	Complete labelling (type information, TAG, Ex label) in Stainless Steel
MAN-	Additional RHE manual printout

Hazardous Area Certifications

Code	Construction Type	Zone / Division	Approval		Labeling
A1	Geh. E*	Zone 1	ATEX		II 2(1)G Ex db eb [ia Ga] IIC T4 Gb
A1	Geh. H*	Zone 1	ATEX		II 2(1)G Ex db [ia Ga] IIC T4 Gb
A2	Geh. E*	Zone 2	ATEX		II 3(1)G Ex db ec [ia Ga] IIC T4 Gc
A2	Geh. H*	Zone 2	ATEX		II 3(1)G Ex db [ia Ga] IIC T4 Gc
AS		safe area	ATEX		II (1)G [Ex ia Ga] IIC
A1	Geh. E*	Zone 1	IECEX		Ex db eb [ia Ga] IIC T4 Gb
A1	Geh. H*	Zone 1	IECEX		Ex db [ia Ga] IIC T4 Gb
A2	Geh. E*	Zone 2	IECEX		Ex db ec [ia Ga] IIC T4 Gc
A2	Geh. H*	Zone 2	IECEX		Ex db [ia Ga] IIC T4 Gc
AS		safe area	IECEX		[Ex ia Ga] IIC
C1		Div 1, Zone 1	Zone USA/Kanada		Class I, Div 1, Zone 1, AEx db [ia Ga] IIC T4 Gb; Ex db [ia Ga] IIC T4 Gb
C2		Div 2, Zone 2	Zone USA/Kanada		Class I, Div 2, Zone 2, AEx nA [ia Ga] IIC T4 Gc; Ex nA [ia Ga] IIC T4 Gc
CS		safe area	Zone USA/Kanada		[Ex ia]; [Ex ia Ga] IIC



About Rheonik

Rheonik has but one single purpose: to design and manufacture the very best Coriolis meters available.

Our research and engineering resources are dedicated to finding new and better ways to provide cost effective accurate mass flow solutions that provide value to our customers. Our manufacturing group care for each and every meter we produce from raw materials all the way to shipping, and our service and support group are available to help you specify, integrate, start-up and maintain every Rheonik meter you have in service. Whether you own just one meter or have hundreds, you will never be just another customer to us. You are our valued business partner.

Need a specific configuration for your plant? Don't compromise with a "standard" product from elsewhere that will add extra cost to your installation. If we can't configure it from our extensive and versatile product range, our exclusive **AnyPipeFit Commitment** can have your flow sensor customized with any size/type of process connection and face to face dimension you need.

No matter what control system you use as the backbone in your enterprise, with our **AnyInterface Commitment**, you can be sure that connection and communication will not be a problem. Alongside a wide variety of discrete analog and digital signal connections, we can also provide just about any network/bus interface available (for example: HART, ProfibusDP, ProfiNet, EtherCAT, PowerLink, EtherNet/IP, CAN,) with our RHE 40 Series family of transmitters. Rheonik RHE 40 Series transmitters can connect to your system – no headache and no conversion needed.



MJ Systems, LLC
Authorized Rheonik Representatives
TX - Off (281) 842-7600
LA - Off (504) 264-7744
www.mjsusa.com • sales@mjsusa.com

