

NOVAPLEX *Integral*

PROCESS DIAPHRAGM PUMPS



Based in Charlotte, North Carolina, SPX Corporation (NYSE: SPW) is a global, multi-industry manufacturing leader with approximately \$5 billion in annual revenue, operations in more than 35 countries and over 14,000 employees. The company's highly-specialized, engineered products and technologies are concentrated in Flow Technology and energy infrastructure. Many of SPX's innovative solutions are playing a role in helping to meet rising global demand for electricity and processed foods and beverages, particularly in emerging markets. The company's products include food processing systems for the food and beverage industry, critical Flow components for oil and gas processing, power transformers for utility companies, and cooling systems for power plants. For more information, please visit www.spx.com.

For more than 80 years, SPX's Bran+Luebbe brand has been providing customers with high quality metering, processing and analysing equipment.

As part of the global SPX Corporation, we are one of the world's most reputable manufacturers of metering and process pumps, process systems as well as analyzing technologies. Our engineers have comprehensive process and applications knowledge across a wide range of markets. This has resulted in product innovations and developments which harness the latest technology whilst meeting the highest quality standards.

Process Diaphragm Pumps

DIAPHRAGM PUMP TECHNOLOGY

The pump heads used on the Novaplex *Integral* utilise the hydraulically actuated diaphragm principle. The plunger movement induced by the crank gear acts on hydraulic oil rather than the process fluid directly.

The hydraulic oil in turn displaces a freely moving diaphragm. This diaphragm acts as an hermetic seal separating the hydraulic fluid from the pumped liquid whilst also ensuring zero leakage to the environment.

The Bran+Luebbe NOVAPLEX is a flexible high performance process diaphragm pump for high flow rates and operating pressures.-

NOVAPLEX *Integral* pumps are powerful process diaphragm pumps for a variety of applications. They are best suited for critical high pressure installations where the capabilities of traditional metering pumps are exceeded.

FEATURES OF THE NOVAPLEX INTEGRAL PROCESS PUMP

- Double diaphragm pumpheads with
 - positive diaphragm position control
 - built-in pressure relief valve
 - diaphragm failure indication
- Crank gears with
 - integrated lubrication system
 - anti-friction bearings
- Modular concept
- Integrated gear reducer
- Minimized footprint
- Compact design

*NOVAPLEX Integral Process Pump
Type N-080i-3D*

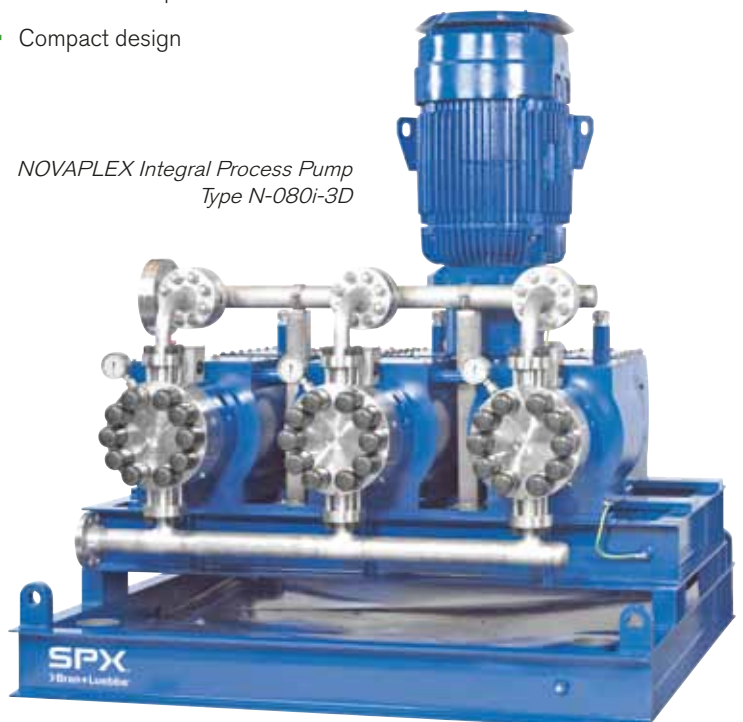



NOVAPLEX Integral Process Pump
Type N-160i-3D

ADVANTAGES

Excellent Emission Control

- Product leakage protection through the use of the double diaphragm design
- Minimal noise levels through the integrated worm gear reducer

High Reliability

- The Bran+Luebbe diaphragm pump head is of proven design, demonstrated on many varied applications, with diaphragm service life time of 20,000 operating hours being achieved under ideal conditions
- Bran+Luebbe diaphragm pump heads are protected against damage caused by overload through an internally mounted pressure relief valve
- Low wear resulting from the simple and well proven lubrication system

Simplified Maintenance

- All pump heads are equipped with an interface for the NOVALINK-CSM 2 diagnostics system
- Modular concept allows easy access to any part of the pump

Minimized Life Cycle Cost

- The use of anti-friction bearings reduces energy consumption
- No additional measures are needed to contain product leakage as the pump head includes zero emission as an inherent feature of its standard design

Special Operating Conditions

- The use of anti-friction bearings allows the pump to run continuously under a wide range of varying speeds, even at high suction pressures.

Typical Applications

NOVAPLEX *Integral* Pumps are ideal for toxic or chemically aggressive liquids and for slurries/suspensions with particle sizes up to 100 µm.

CHEMICAL PROCESSING

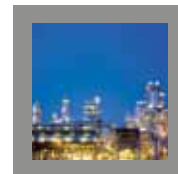

PETROCHEMICAL



OIL & GAS

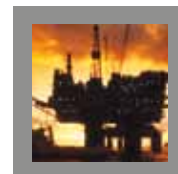

PHARMACEUTICAL



FLUIDS PUMPED (EXAMPLES)

- Ammonia
- Butane
- Hydrocarbon Condensate
- Latex emulsion
- Liquefied CO₂
- LPG (Liquefied Petroleum Gas)
- Methanol,
- Naphtha
- Raney Nickel Suspension
- Sulphuric Acid
- Toluene
- Water

PUMPED DUTIES (EXAMPLES)

- Reactor feed pump
- High pressure injection pump
- Transfer pump
- Re-circulation pump

Function of the Bran+Luebbe diaphragm pump heads & gears

The Bran+Luebbe Positive Diaphragm Position Control (PDPC) system ensures that the diaphragm cannot be damaged even under critical conditions such as blocked pipes or closed valves on both suction or discharge side.

The replenishing valve is activated only when the diaphragm is fully retracted at the end of the suction stroke; the diaphragm itself releases the replenishing valve interlock mechanism by pushing a control pin. This interlock mechanism prevents overfilling of the hydraulic system.

A pressure relief valve within the hydraulic system of the pump head protects not only the pump head but also the pump gear from overload due to excessive pressure.

This protection system allows all liquids to be pumped safely including slurries and suspensions.

ADVANTAGES OF POSITIVE DIAPHRAGM POSITION CONTROL (PDPC)

- Increased diaphragm life compared to non-positive control systems
- Diaphragm protection even under critical operating conditions
- High metering reproducibility due to constant hydraulic volume and permanent de-aeration of the hydraulic oil
- Vacuum operation possible
- Dry running capabilities

ADDITIONAL FEATURES OF DOUBLE-DIAPHRAGM PUMP HEADS

Double-diaphragm pumps with diaphragm condition monitoring system offer higher operation security than single diaphragm pump heads.

A thin circular disc with a capillary system is positioned between the two adjacent diaphragms and connects the interstitial space with the monitoring system. Should either one of the diaphragms be ruptured, the pressure in the interstitial space and the capillary rises. It can be signalled externally by a variety of optional indicating devices such as pressure gauges, pressure switches or pressure sensors.

In the event of one ruptured diaphragm, cross contamination between hydraulic oil and the pumped liquid is prevented. Also, containment of the pumped liquid is still assured therefore avoiding the immediate need for shutting the pump down.

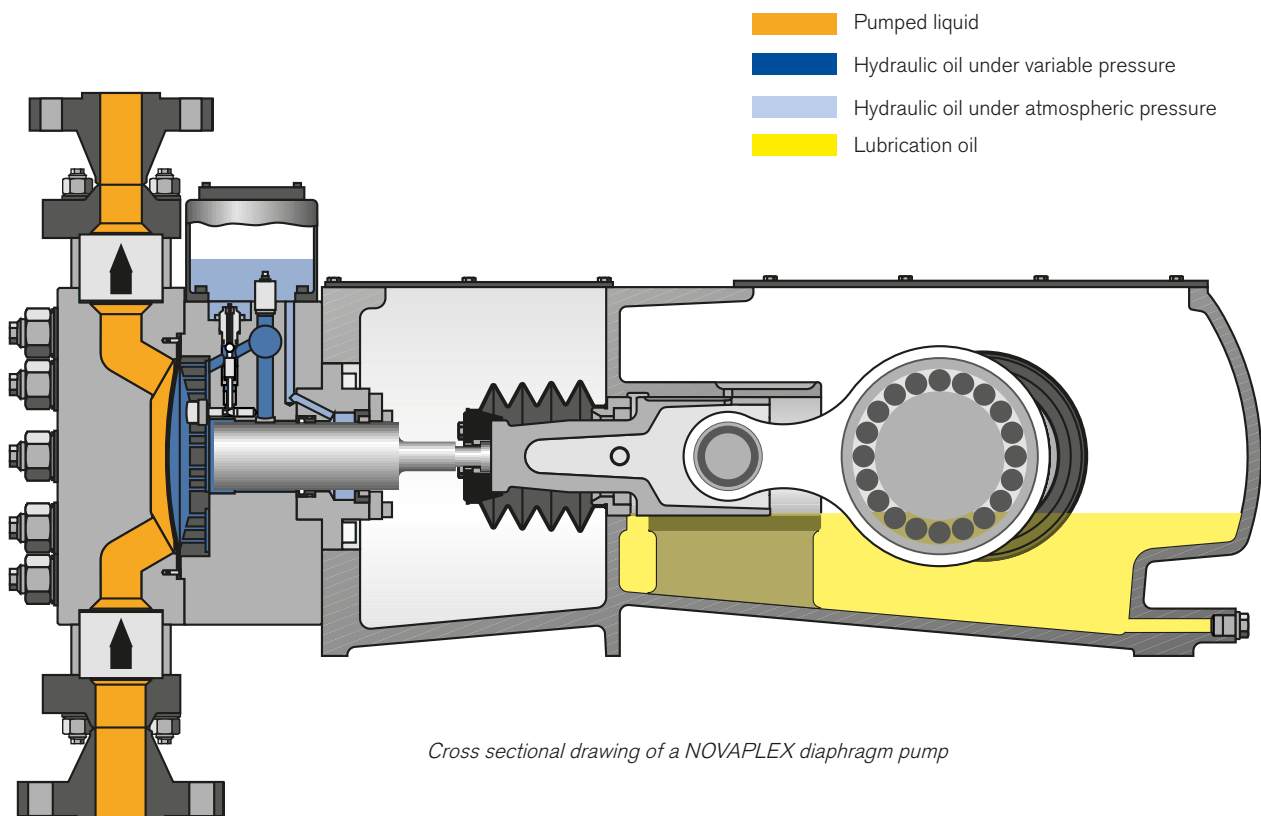

Equipped for your requirements

PUMP HEAD TECHNOLOGY

- Hydraulically actuated PTFE double-diaphragm (up to 400 bar)
- Hydraulically actuated stainless steel double-diaphragm (up to 1000 bar)
- Pump head and valve housing in stainless steel. Special materials available for individual applications
- Suction and discharge valves with various geometries with or without springs. Special designs and materials for valve bodies, e.g. for reduced NPSH value
- All pump heads are equipped with interface for the NOVALINK-CSM 2 diagnostics system

MULTI-HEAD PUMPS

- NOVAPLEX *Integral* process pumps are designed as Triplex pumps
- The integrated gear reducer is based on the proven worm gear technology

FLOW RATE ADJUSTMENT†

Infinitely variable flow rate adjustment is achieved by varying the pump stroking speed

- AC motor with frequency converter
- All other types of variable-speed drive

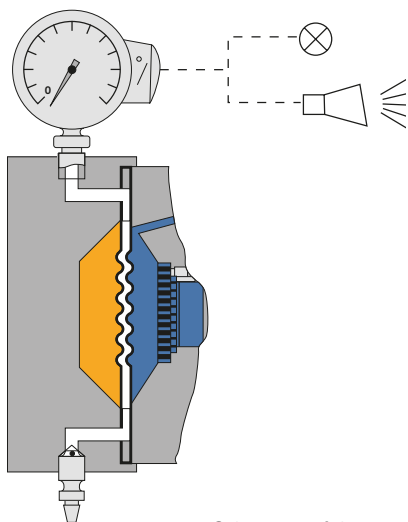

Schematic of the diaphragm condition monitoring system



Layout and dimensions

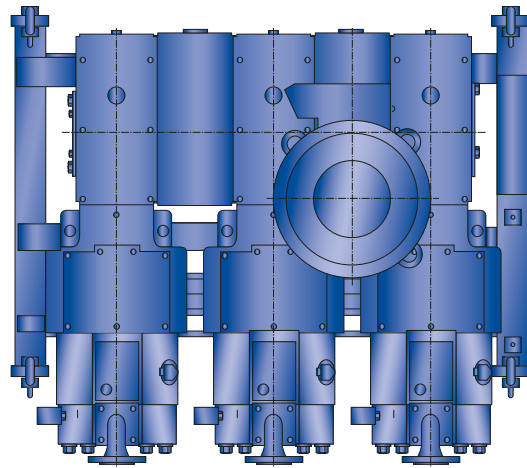
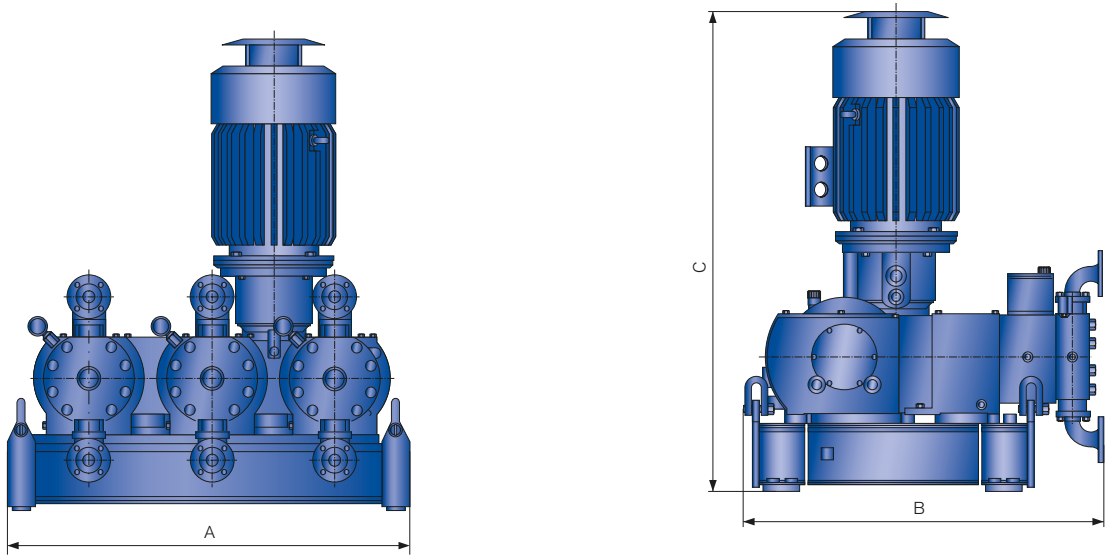

	LENGTH (A)	WIDTH (B)	HEIGHT (C)	APPROX. WEIGHT	OIL CAPACITY	MAX. ELECTR. POWER
	MM	MM	MM	KG	L	KW
N-020-3D	1,345	1,170	1,580	1,800	45	22-37
N-040-3D	1,680	1,550	2,250	5,000	85	45-90
N-080-3D	2,300	1,920	2,500	10,000	150	75-160
N-160-3D	2,650	2,140	2,950	11,800	230	110-250
N-200-3D	2,650	2,140	2,950	11,800	230	132-315

Flowrate for NOVAPLEX *Integral* with PTFE diaphragm

TYPE	PRESSURE (BAR)	MAX. FLOW RATE (L/H)*
N-020	25 - 400	1,730 - 26,500
N-040	63 - 400	3,360 - 22,900
N-080	63 - 400	7,070 - 44,200
N-160	80 - 400	14,000 - 62,300
N-200	100 - 400	17,500 - 62,300

*Theoretical values at 100% volum. efficiency and stroke frequency 200 1/min, 50Hz

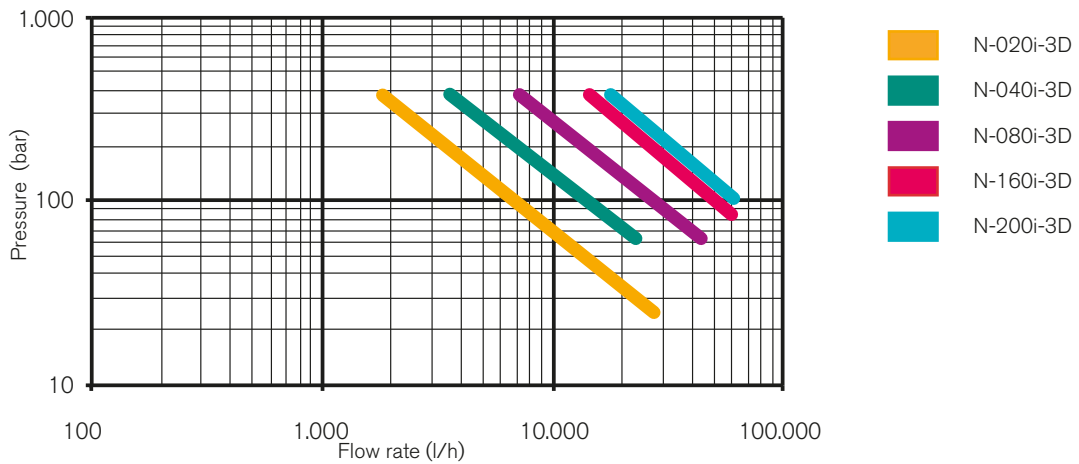

NOVAPLEX *Classic* Process Diaphragm pumps

Alternatively to the NOVAPLEX *Integral* pumps the NOVAPLEX *Classic* with externally mounted gear reducer, enabling an extended number of pump heads, is available.



Process pump NOVAPLEX Classic Type N-160-4D



Global locations

EMEA

SPX FLOW TECHNOLOGY

Werkstraße 4

D-22844 Norderstedt

Phone: +49 (0) 40 - 522 02 -0

Fax: +49 (0) 40 - 522 02 -444

E-Mail: branluebbe@spx.com

EMEA

SPX FLOW TECHNOLOGY

Ironstone Way

Brixworth, Northants, NN6 9UD

Phone: +44 (0) 1604 880751

Fax: +44 (0) 1604 880145

E-Mail: ft.brixworth.sales@spx.com

EMEA

SPX FLOW TECHNOLOGY

P.O. Box 299745,

Downtown Jebel Ali

The Galleries 4

Dubai, U.A.E.

Phone: +971 481 43400

E-Mail: FT.Dubai.sales@spx.com

AMERICAS

SPX FLOW TECHNOLOGY

611 Sugar Creek Road

Delavan, WI 53115 USA

Phone: +1 (800) 252-5200 or

+1 (262) 728-1900

Fax: +1 (262) 728-4904

E-Mail: branluebbe.americas@spx.com

AMERICAS

SPX FLOW TECHNOLOGY

Rua João Daprat, 231

São Bernardo do Campo

SP 09600-010 - Brazil

Phone: +55 11 2127 8278

Fax: +55 11 2127 8260

APAC

SPX FLOW TECHNOLOGY

25 International Business Park

#03-03/12, German Centre,

Singapore 609916

Phone: +65 6568 1568

Fax: +65 6265 9133

E-Mail: asia.pacific@spx.com

APAC

SPX FLOW TECHNOLOGY SHANGHAI OFFICE

1568 Hua Shan Road

5F Treasury Building

Changning District

Shanghai 20052 - PR China

Phone: +86 21 2208 5858

Fax: +86 21 2208 5866

E-Mail: asia.pacific@spx.com

For other Sales locations please visit:
<http://www.spx.com/en/bran-luebbe/contact-us/>
or use your SmartPhone and the QR Code



MJ Systems, LLC
SPX Flow > Bran+Luebbe Representatives
TX - Off (281) 842-7600
LA - Off (504) 264-7744
www.mjsusa.com • sales@mjsusa.com

SPX reserves the right to incorporate our latest design and material changes without notice or obligation.

Design features, materials of construction and dimensional data, as described in this bulletin, are provided for your information only and should not be relied upon unless confirmed in writing. Please contact your local sales representative for product availability in your region. For more information visit www.spx.com.

"The green ">" is a trademark of SPX Corporation, Inc."