



BLISS ANAND



BA-Series Magnetostrictive Level Transmitter



MJ Systems, LLC
Authorized Bliss Distributors
TX - Off (281) 842-7600
LA - Off (504) 264-7744
www.mjsusa.com • sales@mjsusa.com



BA-Series Magnetostrictive Level Transmitter



Index:

Product Overview	02
Product Specifications	03
Agency Approvals	04
Product Dimensions And Mounting	05-06
Ordering Information	07
Programming And Hardware Accessories	08



MAGNETOSTRICTIVE LEVEL TRANSMITTER

PRODUCT OVERVIEW

The Model BAMR3/4 liquid level transmitter satisfies the demand for an analog communication interface for magnetic level gauge (MLG) applications. The Model BAMR3/4 transmitter provides a 4-20mA output for most MLG manufacturers and allows for mounting external to the chamber without interrupting the process.

Model BAMR3/4 transmitters are modular in design offering a selection of mounting options and pipe styles. The modularity also offers simple field replacement. Subject to local electrical codes, the sensing element and electronics can be removed from the transmitter pipe without disturbing the operation of the process saving both time and money

The model BAMR3/4 transmitter uses HART communication for setup, calibration, and diagnostics. HART can be utilized via a hand-held communicator or with the Setup Software via a PC and HART to serial converter. The optional on-board display and keypad is also provided for local indication and programming.

FEATURES

- High accuracy and Repeatability
- 4 to 20 mA analog output with HART®
- No drift due to changes in:
 - Dielectric
 - Vapor Composition
 - Temperature
 - Pressure
- Factory calibrated (No recalibration or maintenance required)
- AMS aware
- Explosion-proof and/or Intrinsically Safe

APPLICATIONS

- Inventory Control
- Process Vessel
- Bypass Chamber

MARKETS

- Petroleum and Petrochemical
- Power Generation
- Specialty Chemical

Certifications:



ISO 14001 : 2004 | OHSAS 18001 : 2007

All specifications are subject to change. Contact Bliss Anand for specifications and engineering drawings that are critical to your application. Drawings contain in this document are for reference purpose only.

MAGNETOSTRICTIVE LEVEL TRANSMITTER



PRODUCT SPECIFICATIONS

Parameters	Specifications
LEVEL OUTPUT	
Measured variable:	Level and Interface
Output signal / Protocol:	4 to 20 mA with HART®
Order length:	Rigid pipe: 508 mm (20 in.) to 3658 mm (144 in.) § Δ Δ Contact factory for longer lengths. § Order length equals the measurement range plus the inactive zone.
Non-linearity:	0.02% F.S. or 0.794 mm (1/32 in.)* * Whichever is greater
Repeatability:	0.01% F.S. or 0.381 mm (0.015 in.)* (any direction) † Contact factory for alternative materials.
COMPATIBILITY	
BAMR3/4 chamber compatibility:	Compatible with all reputed manufacturers
ELECTRONICS	
Input voltage:	10.5 to 36.1 Vdc, 28 Vdc maximum for I.S. approval
Fail safe:	High (21.4 mA), or Low (3.8 mA)
Reverse polarity protection:	Series diode
Lightning/ Transient protection:	Stage 1: Line-to-ground surge suppression; IEC 61000-4-5 Stage 2: Line-to-line and line-to-ground transient suppressors; IEC 61000-4-4

Parameters	Specifications
CALIBRATION	
Zero adjust range:	Anywhere within the active length
Span adjust range:	Full scale to 152 mm (6 in.) from zero
ENVIRONMENTAL	
Enclosure rating:	NEMA Type 4X
Humidity:	0 to 100% relative humidity, non-condensing
Operating temperatures:	E l e c t r o n i c s : -40 °C (-40 °F) to 71 °C (160 °F) Sensing element: -40 °C (-40 °F) to 125 °C (257 °F) ◇ ◇.Contact factory for specific temperature ranges.
FIELD INSTALLATION	
Housing dimensions:	Single cavity: 127 mm (5 in.) by 133 mm (5.25 in.) 123 mm (4.84 in.) O.D.
MOUNTING	
Rigid pipe:	Hose clamp to chamber
WIRING	
Connections:	2-wire shielded cable twisted pair,
ELECTRICAL CONNECTIONS	
Single Cavity:	¾ in. conduit opening, M20 for ATEX / IEC version
DISPLAY	
Measured variables:	Product level
Size:	13 mm (0.5 in.)
Number of digits:	16



MAGNETOSTRICTIVE LEVEL TRANSMITTER

AGENCY APPROVALS

Explosion proof

FM 3615	Class I, Division 1, Groups B, C and D ••
C22.2 No. 30	Class II, Division 1, Groups E, F and G •• Class III, Type 4X, T4 •• Explosion-proof housing required

Intrinsically safe

C22.2 No. 157	Class I, Division 1, Groups A, B, C and D Class II, Division 1, Groups E, F and G Class III, Type 4X, T4
FM 3610	Class I, Division 1, Groups C and D order length < 300 inches Class I, Division 1, Group D order length > 300 inches Class II, Division 1, Groups E, F, and G Class III, Type 4X, T4

Analog Setup Software

Bliss Anand provides a Setup Software to help customers program and customize their Model BAMR transmitter.

The Model BAMR3/4 transmitter is programmed through the HART interface. This interface is easily connected to a PC by using the HART-to-Serial converter. The Analog Setup Software allow the user to adjust both 'Zero' (4 mA) and 'Span' (20 mA) setpoints, adjust HART parameters, and customize the optional built-in display. Setup software is shipped with each transmitter order. However, if you require an additional copy or an upgrade to your currently installed Setup Software, consult factory.

HART® handheld communicator programming

The Model BAMR3/4 transmitter programming can also be performed by using handheld HART communicator device such as the Rosemount® 375 or 475.

Setpoint programming using the display

Any Model BAMR3/4 transmitter that is purchased with a display has the ability to adjust the 4 and 20 mA setpoints by pressing the appropriate button located at the bottom of the display.

MAGNETOSTRICTIVE LEVEL TRANSMITTER



PRODUCT DIMENSIONS AND MOUNTING

Bliss offers the Level Plus Model BAMR3/4 transmitter configured for external mounting to most Magnetic Level Gauges (MLG) (see 'Figure 1'). The model BAMR can be ordered with the standard 5/8 inch OD pipe or the optional 1/2 inch OD pipe from 508 mm (20 in.) to 3658 mm (144 in.). Stainless steel hose clamps are typically used to secure the model BAMR to the MLG.

The Model BAMR transmitter 'Measuring Range' is equal to the 'Order Length' minus the 'Inactive Zone'. The 'Measuring Range' should equal the measuring range of the MLG. Ensure that there are no obstructions that will limit the ability to mount the model BAMR on the MLG.

Figure 1. Bliss MLT mounting, bottom flange

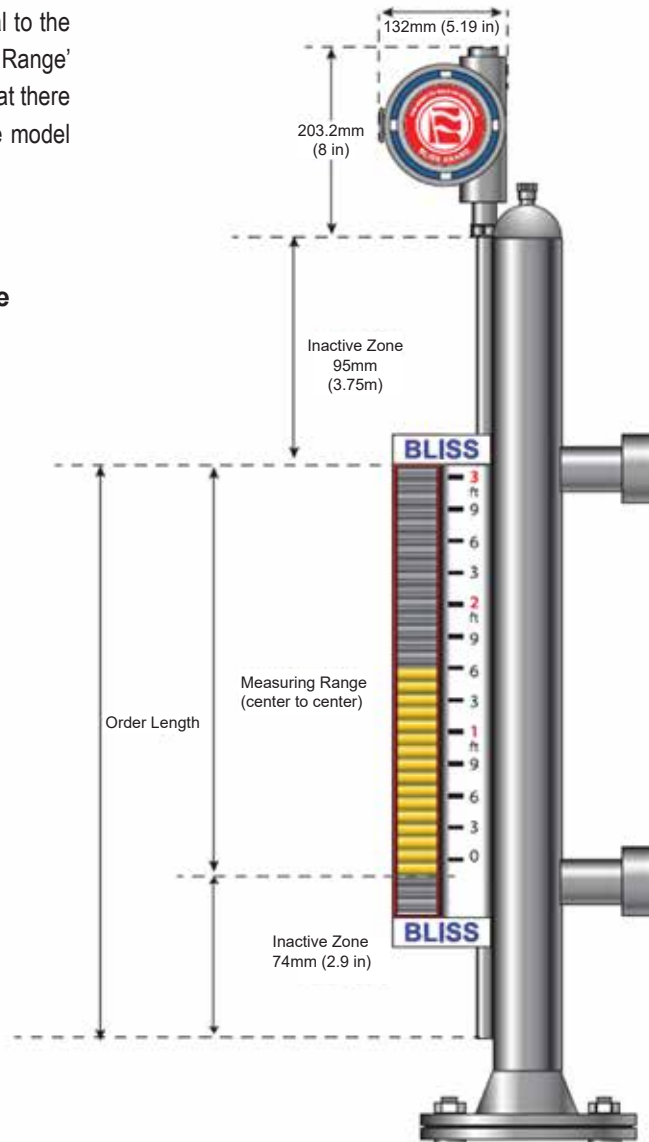



MAGNETOSTRICTIVE LEVEL TRANSMITTER

PRODUCT DIMENSIONS AND MOUNTING

Bliss offers the Level Plus Model BAMR3/4 transmitter configured for external mounting to most Magnetic Level Gauges (MLG) (see 'Figure 2'). The model BAMR can be ordered with the standard 5/8 inch OD pipe or the optional 1/2 inch OD pipe from 508 mm (20 in.) to 3658 mm (144 in.). Stainless steel hose clamps are typically used to secure the model BAMR to the MLG.

The model BAMR offers an optional 90 degree fitting for an MLG with both top and bottom flanges. The 90 degree fitting allows the electronic head of the Model BAMR to be positioned to the side of the pipe allowing for simpler mounting.

The Model BAMR transmitter 'Measuring Range' is equal to the 'Order Length' minus the 'Inactive Zone'. The 'Measuring Range' should equal the measuring range of the MLG. Ensure that there are no obstructions that will limit the ability to mount the model BAMR on the MLG.

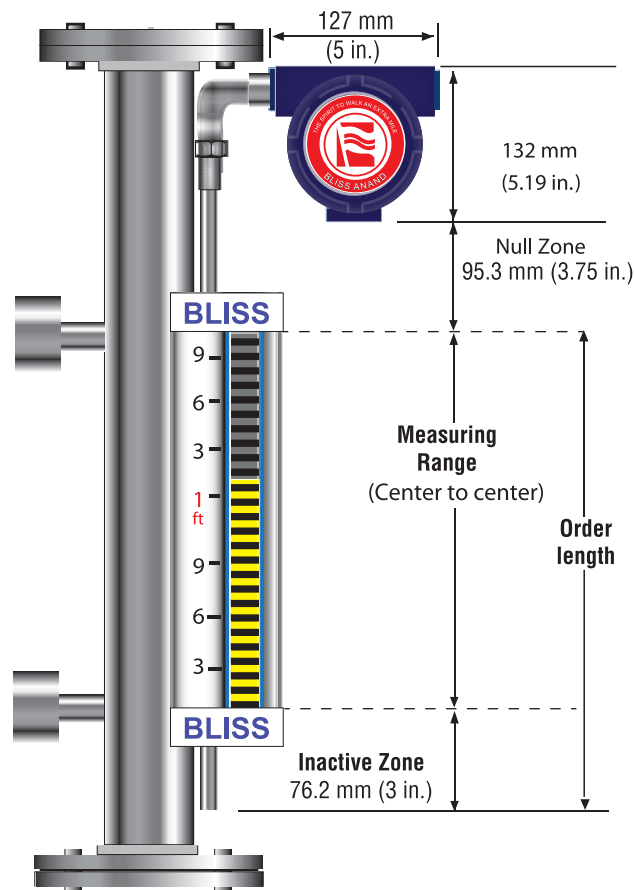

Figure 2. BLISS MLT mounting, top and bottom flange

Bliss Anand - Magnetostrictive Level Transmitter Selection Guide

Ordering information for FM and CSA Approvals

Selection	Suffix Codes														Description	
Bliss Anand MLT	BA															
A Transmitter Model		M														Magnetostrictive transmitter
B Type			R													Analog output liquid-level transmitter
C Approval Agency				F												FM
				C												CSA
D Output					3											4-20 mA Single loop with Display
					4											4-20 mA Single loop no display
E Housing Type						B										Single cavity (explosion-proof and intrinsically safe)
						D										Single cavity with display (explosion-proof and intrinsically safe)
F Electronics Mounting							1									Integral electronics
							3									90° fitting, housing top left
							4									90° fitting, housing top right
							5									90° fitting, housing bottom left
							6									90° fitting, housing bottom right
G Transmitter Pipe							B									Industrial pipe, 5/8 in. OD
							R									Industrial pipe, ½ in. OD
H Material of Construction (Wetted Parts)							1									316L stainless steel
							X									Other (contact factory)
I Process Connection Type								X								Clamp
J Process Connection Size									X							Level Gauge Chamber
K Temperature										0						None
L Unit of Measurement											M					Metric (mm), %
											U					US Customary (inches)
M Length												XXXX				Order Length
N Special													S			Standard product
														E		Engineering special (not affecting agency controlled parts or features)

Note : Other Information as per data sheet.

Bliss Anand - Magnetostrictive Level Transmitter Selection Guide

Ordering information for ATEX and IECEx Approval

Selection		Suffix Codes														Description		
	Bliss Anand MLT	BA																
A	Transmitter Model	M																Magnetostrictive transmitter
B	Type		R															Analog output liquid-level transmitter
C	Approval Agency			E														ATEX
				H														IECEx approval
				P														CCoE approval
				X														Other approval (Specify)
D	Output				3													4-20 mA Single loop with display
					4													4-20 mA Single loop no display
E	Housing Type					B												Single cavity (Flameproof IIB) & IP-66
						D												Single cavity with display (Flameproof IIB) & IP-66
						G												Single cavity (ATEX Ex ia IIA) & IP-66
						J												Single cavity with display (ATEX Ex ia IIA) & IP-66
						R												Single cavity (ATEX Ex ia IIB) & IP-66
						T												Single cavity with display (ATEX Ex ia IIB) & IP-66
F	Electronics Mounting						1											Integral electronics
							3											90° fitting housing top left (Flameproof only)
							4											90° fitting housing top right (Flameproof only)
							5											90° fitting housing bottom left (Flameproof only)
							6											90° fitting housing bottom right (Flameproof only)
G	Transmitter Pipe							B										Industrial pipe, 5/8 in. OD
								R										Industrial pipe, ½ in. OD
H	Material of Construction (Wetted Parts)								1									SS 316
									X									Other (contact factory)
I	Process Connection Type									X								Clamp
J	Process Connection Size										X							Level Gauge Chamber
K	Temperature											0						None
L	Unit of Measurement												M					Metric (mm), %
													U					US Customary (inches)
M	Length													XXXXX				Order Length
N	Special														S			Standard product
															E			Engineering special (not affecting agency controlled parts or features)

Note : Other Information as per data sheet.

MAGNETOSTRICTIVE LEVEL TRANSMITTER



PROGRAMMING AND HARDWARE ACCESSORIES

Programming Accessories	Part Number
BA-Series Model BAMR3/4 PC setup software on CD
BA-Series Model BAMR3/4 PC setup software on CD Includes HART adapter, part no. 380068
HARDWARE	
HART to RS-232 adapter (SMAR H1-311)

All specifications are subject to change. Contact Bliss Anand for specifications and engineering drawings that are critical to your application. Drawings contain in this document are for reference purpose only.



BLISS ANAND



MJ Systems, LLC
Authorized Bliss Distributors
TX - Off (281) 842-7600
LA - Off (504) 264-7744
www.mjsusa.com • sales@mjsusa.com

Manufacturing Locations:

UNITED STATES OF AMERICA

202 Industrial Blvd #804,
Sugar Land, TX 77478, USA
blissamericas.com

THE NETHERLANDS

Tijvoortsebaan 8Q,
5051 HJ Goirle,
The Netherlands
Ph.: +31 (0) 13 304 0111
e-mail: sales@blisseurope.eu

UNITED ARAB EMIRATES

P.O. Box: 18576, S40412A,
Jebel Ali Free Zone South,
Dubai, U.A.E.
Ph.: 00971-4-883 56 33
Fax: 00971-4-883 56 44
e-mail: reception.gesme@blissanand.com

KINGDOM OF SAUDI ARABIA

Production Unit #101, B-2,
Cluster 2, Modon Industrial City 3,
Zip code -34847, KSA-Dammam
Phone: +966 (0) 56 678 4945
e-mail: ksa@blissanandusa.com

INDIA

Plot No. 240, Sector-3,
Growth Center, HSIIDC,
Bawal, Haryana, India
Ph.: +91 (1284) 269400-99
Fax: +91 124 2290884
e-mail: sales@blissanand.com



UNITED STATES OF AMERICA | UNITED ARAB EMIRATES
INDIA | THE NETHERLANDS | KINGDOM OF SAUDI ARABIA

www.blissanand.com