

Triplex Plunger Pump K 8000 – 3G

P 5-1

27.04.2020

Suited to a variety of purposes, the K 8000 performs in small-scale industry applications such as industrial cleaning and jetting to pumping special media such as sea water, glycol, methanol or oils. At 80 kW, it is a compact KAMAT high-pressure pump design. The classic KAMAT modular component system enables customization for different application requirements. The pump consists of relatively few parts simplifying maintenance and increasing reliability. For this pump size, the KAMAT high-pressure pumps are supplied with an integrated gear reduction-ratio.

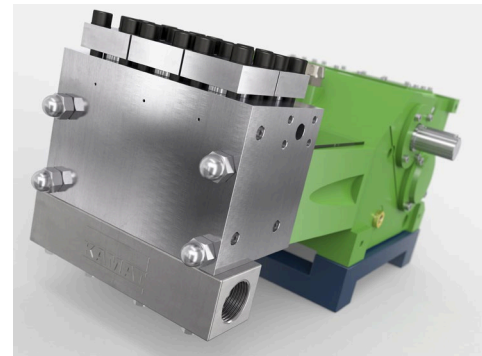
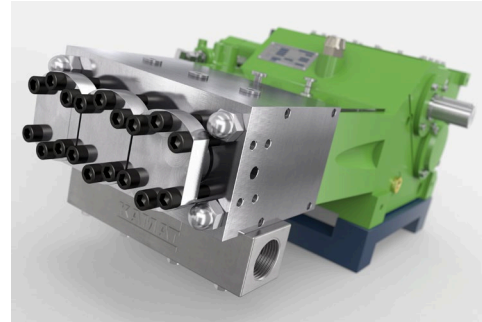

- Flow rate based upon 100% volumetric efficiency and 20°C ambient temperature
- Minimum inlet pressure depends on fluid medium
- Speed range 10-100% depending on rod force
- Gear with splash lubrication
- Standard gear ratios
 $i = 2,75 - 3,22 - 3,68$
- API 674 and ATEX versions available

$n_{nom} = 530 \text{ 1/min}$		p max. bar @ kW			Head type		
Type	l/min	45 kW	55 kW	75 kW	A	M	MC
K 8012 – 3G	13	1770	2160	2950	1		
K 8014 – 3G	18	1280	1590	2150	1		
K 8016 – 3G	24	980	1220	1660	1		
K 8018 – 3G	30	800	965	1300	1		H
K 8020 – 3G	37	660	800	1065	1		H
K 8022 – 3G	45	545	665	890	1		H
K 8024 – 3G	54	460	555	755	1		H
K 8026 – 3G	63	390	475	645	1		H
K 8028 – 3G	73	335	410	555	1		H
K 8030 – 3G	84	280	345	470	1	1	H
K 8032 – 3G	96	245	300	410	1	1	1
K 8036 – 3G	121	190	235	320		1	1
K 8040 – 3G	150	155	190	255		1	1
K 8045 – 3G	190	120	150	200			1
K 8050 – 3G	234	60	85	105			1
K 8055 – 3G	283	80	100	135			1

API 674 = max. 400 1/min

= Ultra High Pressure UHP

Dimensional Drawing K 8000 – 3G ~ 250 kg P 5-2
01.05.2017

Typ A
Type A

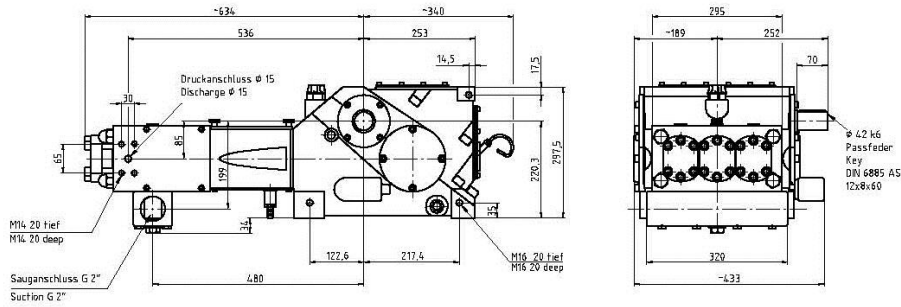

Typ M
Type M

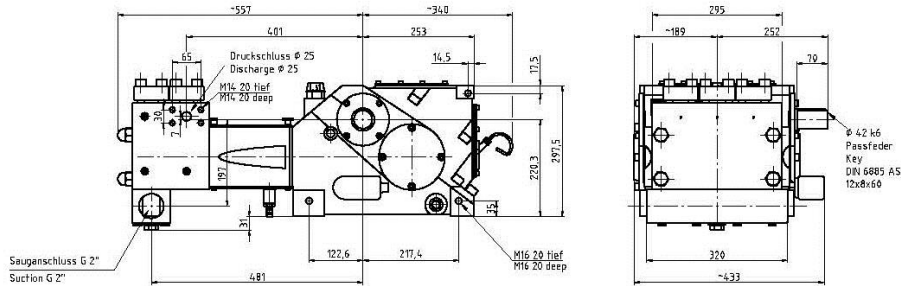

Typ MC
Type MC

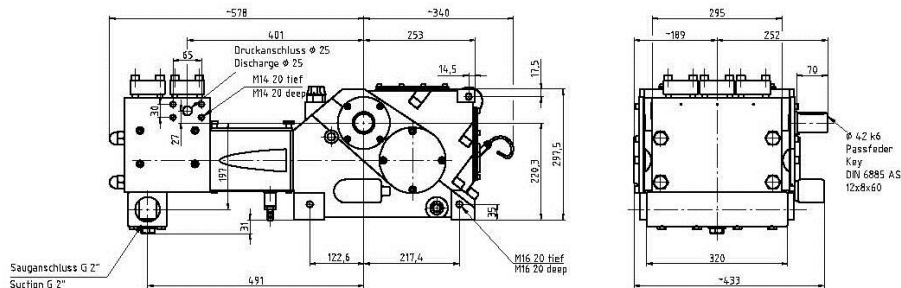

Typ MCH
Type MCH

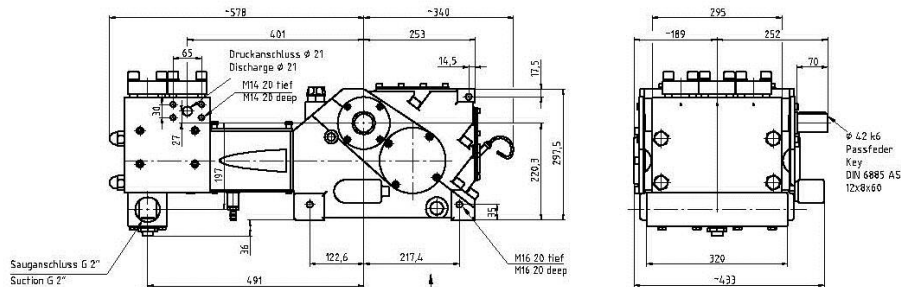

Typ A
Type A
 ≥ 1500 bar

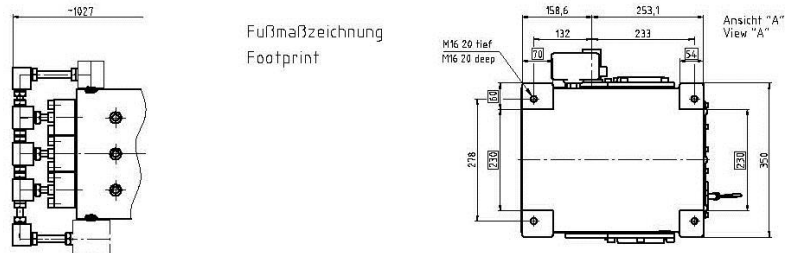

Fußmaßzeichnung
Footprint