

# Hydra•Cell<sup>®</sup>

METERING SOLUTIONS™

Metering Pumps with “Pulse-Free” Linear Flow



MJ Systems, LLC  
HydraCell / CheckPoint Distributors  
TX - Off (281) 842-7600  
LA - Off (504) 264-7744  
www.mjsusa.com • sales@mjsusa.com



Wanner Engineering, Inc.



## Hydra-Cell® Metering Solutions

<b>Contents</b>	<b>Page</b>
An Extraordinary Metering Pump.....	3
Applications & Markets Served.....	4
Hydra-Cell Metering Solutions Installations .....	6
Operational & Cost Advantages	
Electronic Flow Control.....	8
Reduced Pulsations.....	9
Materials of Construction.....	10
Economy through Technology .....	11
Design Features & Benefits.....	12
API 675 Performance Standards	
Accuracy .....	14
Linearity.....	15
Repeatability.....	15
Metering Pump Selection Reference.....	16
Flow Capacities & Pressure Ratings	
Gallons per Hour (gph).....	17
Liters per Hour (lph) .....	18
Model Specifications & Ordering Information	
P100 .....	19
P200 .....	23
P300 .....	27
P400 .....	31
P500 .....	35
P600 .....	39
MT8 Triplex Metering Pump	
Overview .....	43
Applications & Configurations.....	44
Specifications & Ordering Information .....	45
S Series Solenoid Metering Pumps.....	50
Bare Shaft Pumps for Metering.....	51
System Illustration .....	52
Hydra-Cell Metering Accessories & Options .....	52
Glossary of Terms .....	70
Other Wanner Engineering Pumps .....	72
Warranty.....	74
Worldwide Sales & Service.....	75



**ISO 9001: 2015  
CERTIFIED**

“If the owner of a plant wants cost-effective pumps...he will buy pumps with the lowest Life Cycle Cost. Hydra-Cell is simple in construction, less elaborate in design and physically smaller for equivalent flow/pressure performance. These differences can substantially affect both purchase and operating costs.”

Ing Friedrich-Wilhelm Hennecke, Ph.D.  
*Chemical Engineering World*

*Dr. Hennecke served on the Faculty of Chemical Engineering, Karlsruhe, and as a plant engineer, specifying pumps at BASF AG for 30 years.*

Due to the Wanner Engineering Continuous Improvement Program, specifications and other data in this catalog are subject to change.

Hydra-Cell® and Kel-Cell® are registered trademarks of Wanner Engineering, Inc. Control Freak™ is a trademark of Wanner Engineering, Inc.

# Hydra-Cell® Is Not a Conventional Metering Pump



Six P Series metering pumps (P400 shown) offer a wide range of maximum flow capacities, the highest up to 890 gph (2808 lph) with discharge pressures up to 2500 psi (172 bar) depending on the model. They exceed API 675 Standards and provide linear, virtually pulse-free flow.

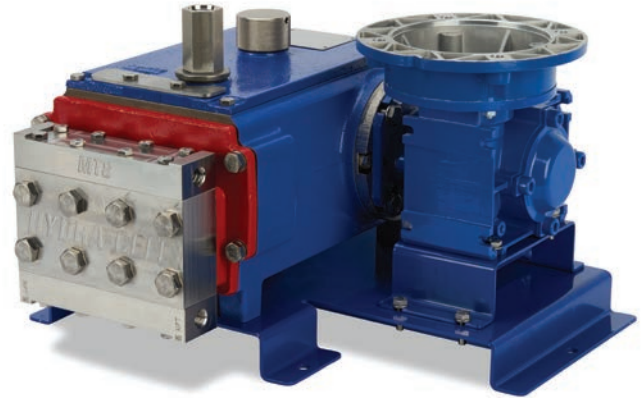

MT8 triplex metering pumps are designed for applications with low flow rates at discharge pressures up to 3500 psi (241 bar). Minimum flow is 0.06 gph (0.227 lph) and maximum flow is 8.00 gph (30.28 lph). The MT8 also exceeds API 675 Standards and provides linear, virtually pulse-free flow.

## Hydra-Cell METERING SOLUTIONS™

The technology used to produce metering pumps has barely changed in over a generation. As a result, conventional metering pumps have operational limitations and greater cost consequences.

Hydra-Cell is not a conventional metering pump. Hydra-Cell Metering Solutions pumps enable you to meet and, in most cases, exceed API 675 performance standards with linear, virtually pulse-free flow (except the single-diaphragm model PI00) while providing many other operational benefits.

Taking advantage of the most current technologies, Hydra-Cell metering pumps achieve superior levels of accuracy, repeatability and linearity, while delivering precise, accurate flow. This revolution in metering employs the latest available means of electronic flow control to replace antiquated, inaccurate stroke adjusters.

To maintain accuracy in a hydraulically-actuated metering pump, the volume of oil on the non-process side of the diaphragm must remain constant. Conventional metering pumps rely on vacuum sensing or mechanical activation to compensate for leakage past the plunger. They may not compensate on every pump stroke.

Hydra-Cell pumps incorporate a replenishment valve in every piston assembly. This ensures optimum actuating oil

volume on every diaphragm stroke to provide superior accuracy that exceeds the performance standards of API 675.

In addition, the modern design features of the Hydra-Cell pump lower your acquisition costs when compared to conventional metering pumps, and its inherently simple yet elegant engineering keeps your maintenance and replacement costs down. Rugged construction and long-lasting durability will provide economy and value over the lifetime of your Hydra-Cell metering system.

Used in place of conventional metering pumps, Hydra-Cell is an extraordinary metering pump that provides superior performance at a lower cost. It is built to handle your precise metering and dosing applications without the “slugs” and destructive operation of pulsing, single-diaphragm metering pumps.

*The IChemE Awards recognize innovation and excellence in making outstanding contributions to safety, the environment, and sustainable development in the chemical and bioprocess industries.*



# Hydra-Cell® Applications and Markets Served

## Primary Pumping Applications

- Adding
- Blending
- Coating
- Dosing
- Filling
- Filtering
- Injecting
- Metering
- Mixing
- Spraying
- Transferring

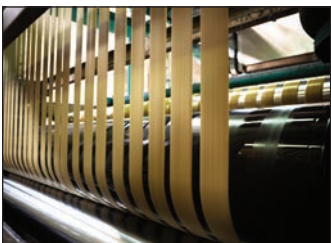

## Fluid Handling Capability



Propane/ Butane    Freon    Ammonia    Polymers    Fuels/ Additives    D.I. Water    Glycols    Chlorine    Acids/ Caustics    Glues/ Adhesives    Inks/ Paints    Resins    Slurries

From drinking water to viscous resins, Hydra-Cell metering pumps can handle the full spectrum of process fluids while maintaining high-efficiency operation. This includes non-lubricating fluids as well as difficult fluids with abrasives that

can damage or destroy other types of pumps. P Series pumps also feature a horizontal disk check valve that offers superior handling of particulates.

## Markets and Industries Served

- Agricultural
- Automotive
- Biodiesel
- Biotechnical
- Ceramics
- Chemical & Petrochemical
- Chip Board Manufacturing
- Construction
- Electronics
- Emissions & Environmental Control
- Energy & Power Generation
- Flue Gas Emission Control
- Food & Beverage Processing
- General Industrial & Manufacturing
- Glass & Clay
- Landscaping & Lawn Care
- Marine
- Mining, Quarrying & Tunneling
- Offshore Drilling & Processing
- Oil, Gas & Petrochemical
- Paints, Coatings, Sealants & Adhesives
- Personal Care
- Pharmaceutical
- Polyurethane
- Propellant Packaging
- Pulp & Paper
- Reverse Osmosis & Filtration
- Rubber & Plastic
- Spray Drying
- Steam Generation
- Steel
- Textiles
- Water & Wastewater Treatment

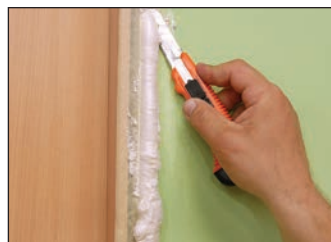

# Hydra-Cell® Metering Solutions Installations



*P400 used with several metering accessories in a testing laboratory.*

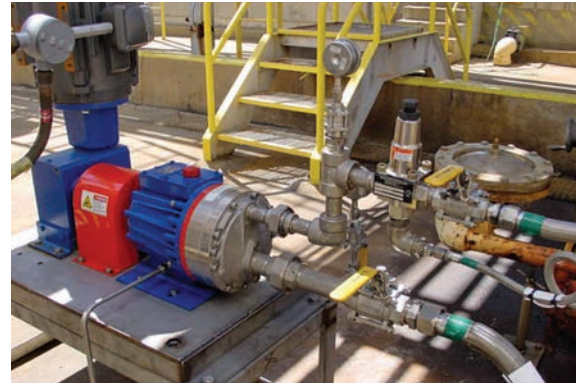

*P600 used to inject Ammonia. Shown with a Hydra-Cell C62 pressure regulating valve.*

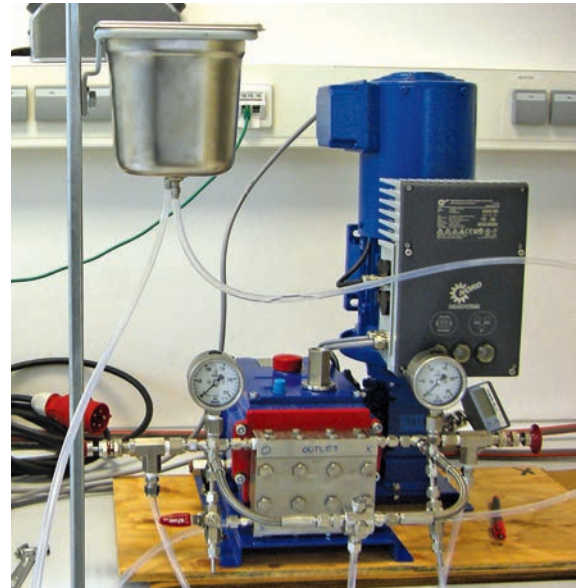

*MT8 pumping aqueous and solvent-based pigment emulsions.*



*A P200 replaced a conventional single diaphragm pump in a refinery application to eliminate pulsing flow and noise.*



*P400 used for spray drying of non-lubricating as well as viscous flavor additives in the food processing industry.*



Three P500 models replaced six piston pumps for spraying an adhesive colorant and substantially reduced maintenance costs.



P400 skid to produce Oriented Strand Board (OSB) in the engineered wood industry.



Dual P400 skid system with corrosion-resistant materials to meter Sulfuric Acid.



MT8 pump used for anti-scalant.

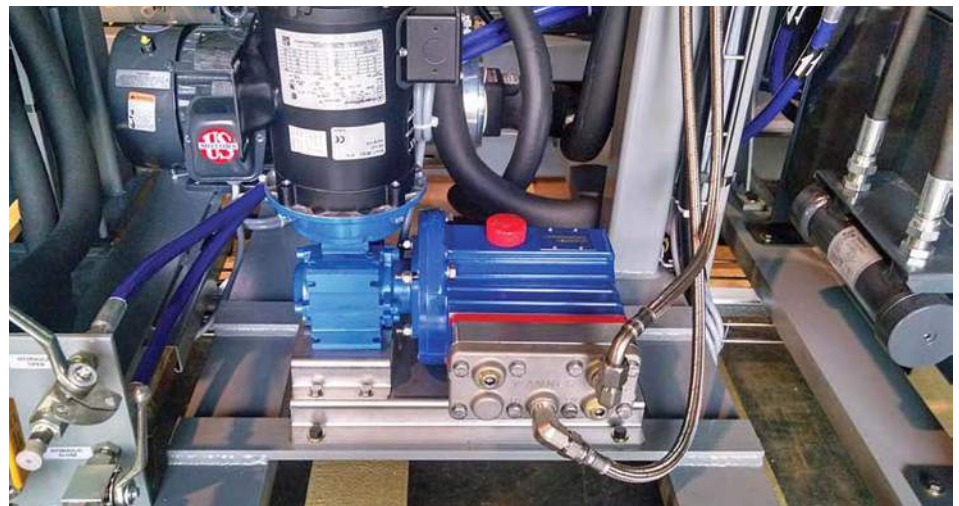

A P200 replaced an external gear pump to deliver a catalyst for polyurethane foam production and doubled volumetric efficiency.



Chemical boiler feed at a power plant. Four MT8 pumps running off two gearboxes and two motors shows its duplexing capability.



Ground stabilization in an earthquake zone requires precise metering, a small footprint, and virtually pulse-free flow provided by this P400.

# Hydra-Cell® Operational and Cost Advantages

## Electronic Flow Control Is More Accurate and Reliable

Conventional metering pumps rely on manual stroke adjustment or expensive actuators to change flow. This can result in pumping inaccuracies, lost motion, operator error, and a greater chance of leakage.

Hydra-Cell uses Variable Frequency Drive (VFD) electronic flow adjustment to maintain greater accuracy throughout the turndown range. It meets or exceeds API 675 performance standards while eliminating lost motion and a potential leak path.

Compared to many conventional metering pumps, electronic flow control of Hydra-Cell also reduces the chance of operator error.

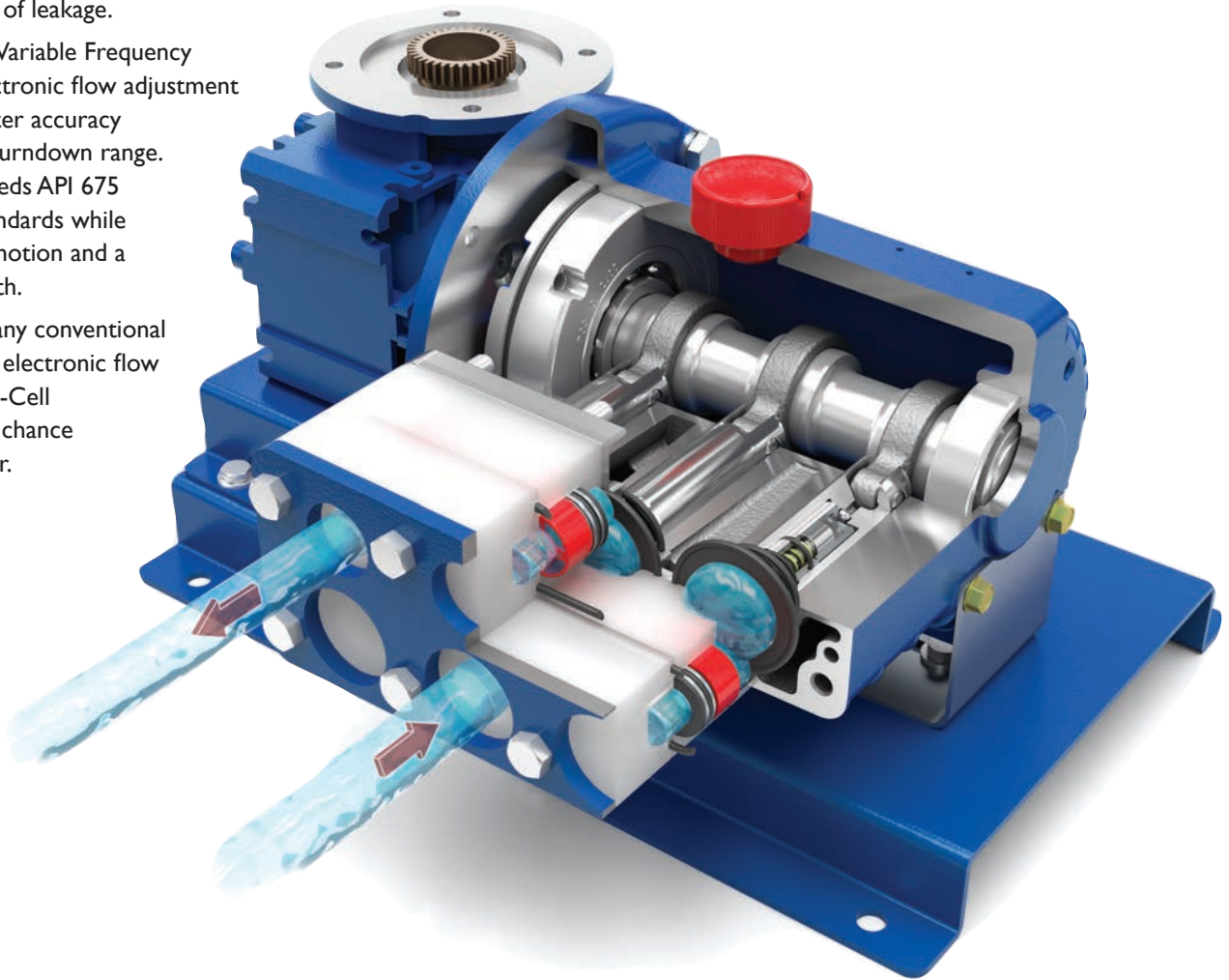

Hydra-Cell with Electronic Flow Control	Other Pumps with Manual Stroke Adjusters/Actuators
Solid-state electronics (SCR, VFD, or solenoid pulser) are unlikely to fail	Stepper motors or linear actuators driving against pressure are subject to wear and tear
Metering is linear over the entire range	Losses in repeatability below 30% stroke length and losses through check valves
Volume per every stroke is constant and a known value	Unknown with manual stroke adjustment and may not be proportional to the output
Easy calibration of the desired feed rate	Nearly impossible to calibrate unless a variable stroke rate or span-able controller is used
Rate of change is virtually instantaneous (0 to maximum rpm in 0.3 seconds) with AC motors and appropriate drive	Up to one (1) second per 1% of the stroke length

# Hydra-Cell® Operational and Cost Advantages

## Accurate Metering with Linear, Virtually Pulse-free Flow

Conventional metering pumps produce pulsing, surging flow and require large pulsation dampeners that add cost and complexity to a metering system. This inherent problem with conventional metering pumps creates greater strain on the system and more wear and tear on the pump.

Hydra-Cell Metering Solutions pumps (except the P100 and S Series) feature a multiple-diaphragm design that minimizes pulsations. This produces smooth, linear, virtually pulse-free flow without the need for expensive pulsation dampeners.

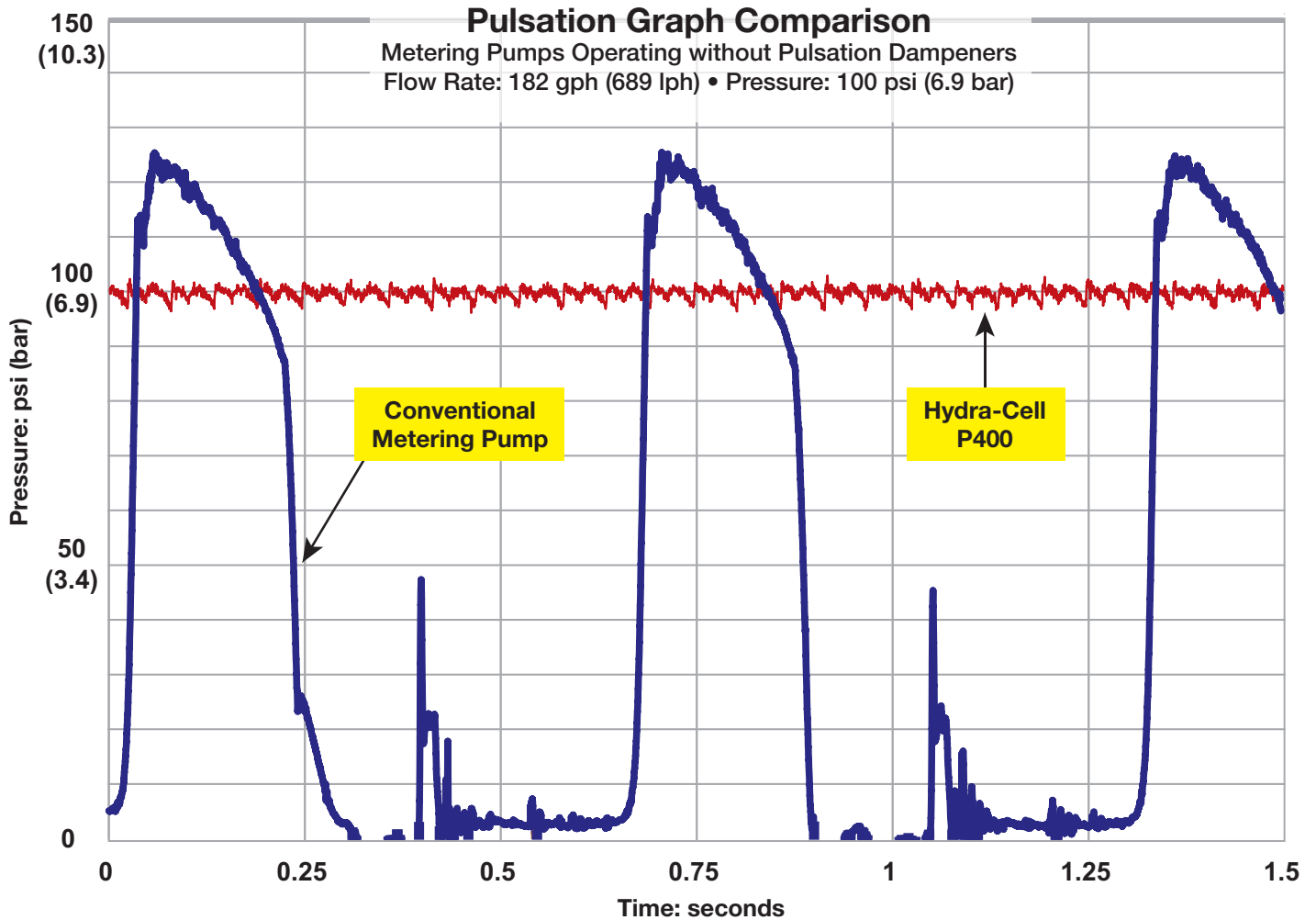

Compared to conventional metering pumps operating under the same conditions at the same flow and pressure, Hydra-Cell metering pumps provide smooth, almost pulse-less performance.

This allows for the design of a safer, less expensive metering pump system that can be used in more accurate applications, such as spraying, which cannot tolerate pulsing flow.

## Reduced Pulsations Improve Operation

- Reduces pipe strain
- Enhances operating safety
- Minimizes maintenance
- Reduces friction and acceleration losses
- Eliminates the need for pulsation dampeners
- Lowers system acquisition costs
- Provides accurate metering and injecting with linear, constant flow and eliminates the “slugs” common to conventional metering pumps

# Hydra-Cell® Operational and Cost Advantages

## Greater Choice of Materials Enhances Capability and Versatility

A choice of diaphragm, check valve, and liquid end materials enables Hydra-Cell Metering Solutions pumps to operate over a wider range of processing applications than conventional metering pumps. In addition, special materials such as PVDF

and Hastelloy C are available in standard Hydra-Cell packages. Hydra-Cell is lower in cost compared to conventional metering pumps that have substantial price adders for exotic liquid end materials.

### Manifolds



Manifolds for Hydra-Cell Metering Solutions pumps are available in metallic and non-metallic materials to suit your process application. They are easy to replace and interchangeable to accommodate different fluids processed by the same pump. Special manifolds are also available that offer 2:1 ratio pumping or the simultaneous pumping of three dissimilar fluids. (Consult factory.)

### Valves



Hydra-Cell Metering Solutions valve assemblies (seats, valves, springs, and retainers) are available in a variety of materials to suit your process application.

### Diaphragms and O-rings



Conventional metering pumps typically offer only PTFE diaphragms. When subjected to flex stresses, PTFE diaphragms do not have a “memory” like elastomeric diaphragms and will require more frequent and costly replacement due to stresses on the material. In addition, if fluid and process temperatures are low, and the PTFE diaphragm is cold, it can stiffen and cause irregularities in the output and a drop in flow.

Hydra-Cell offers PTFE diaphragms, as well as many other elastomeric material choices that may be more cost-effective or better suited to the application.

- Aflas
- EPDM
- FKM
- Neoprene
- Buna-N

### Registered trademarks of materials:

Aflas®	Asahi Glass Co., Ltd.
Buna®-N (Nitrile)	E.I. Du Pont de Nemours and Company, Inc.
Celcon®	Celanese Company
Elgiloy®	Elgiloy Limited Partnership
Hastelloy® C	Haynes International, Inc.
Kynar® (PVDF)	Arkema, Inc.
Mesamoll®	Lanxess Deutschland GmbH
Neoprene®	E.I. Du Pont de Nemours and Company, Inc.
Nitronic® 50	AK Steel Corporation
Teflon® (PTFE)	E.I. Du Pont de Nemours and Company, Inc.
Viton® (FKM)	DuPont Performance Elastomers, LLC
Zytel® (Nylon)	E.I. Du Pont de Nemours and Company, Inc.

# Hydra-Cell® Operational and Cost Advantages

## Achieve Economy through Technology

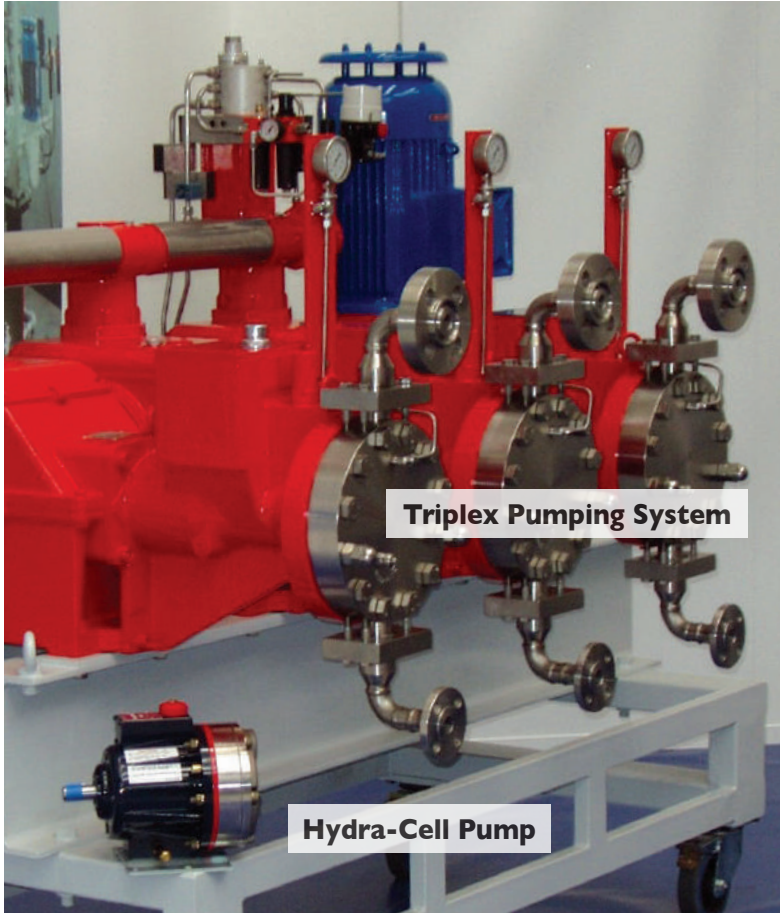

Both the Hydra-Cell pump and triplex metering pump shown have the same flow capacity and pressure rating. Hydra-Cell has a much smaller footprint, however, saving valuable floor space in your facility. Drastically smaller footprint equates to less expensive maintenance and reduced costs of spares. Conventional metering pumps can become over-sized and overpriced as flow and pressure requirements increase.

### Ratings

---

Flow: 396 gph (1500 lph)

---

Pressure: 1160 psi (80 bar)

---

### Pumps Shown to Scale

Conventional metering pumps use technology in existence or unimproved upon for many years. This poses limitations such as inaccurate stroke adjusters, pulsation problems, restricted choice of materials, narrow adjustable flow ranges, and different plunger and diaphragm sizes. In addition, large footprints may be needed to handle high flows and pressures. Other pumps can also have difficulty handling slurries and suspended solids. Conventional metering pumps result in higher costs of acquisition, maintenance, and replacement.

Hydra-Cell combines simple, elegant engineering with rugged construction to offer greater versatility while lowering life cycle costs. Design advantages include:

- Seal-less design means no mechanical or dynamic seals, cups, or packing to leak or replace.
- Smaller footprint that offers the same capability as larger, typically higher-priced pumps.
- Each model covers an extensive range of pressures and flows, whereas ordinary metering pumps may need different plunger and liquid end sizes to accommodate increases.
- The inherent simplicity of the Hydra-Cell design allows versatile application compared to complex metering pumps that require expensive construction changes to meet specific needs.
- Simplicity also means lower parts and maintenance costs.
- A separate gearbox allows greater versatility in changing applications and prevents cross-contamination of actuating oil; integral gearing on other pumps is difficult and expensive to change.
- A replenishment valve in every piston assembly ensures optimum actuating oil on every stroke for continuous accuracy - other metering pumps can leak oil past the plunger and may not be able to compensate on every stroke.

# Hydra-Cell® P Series Design Features and Benefits

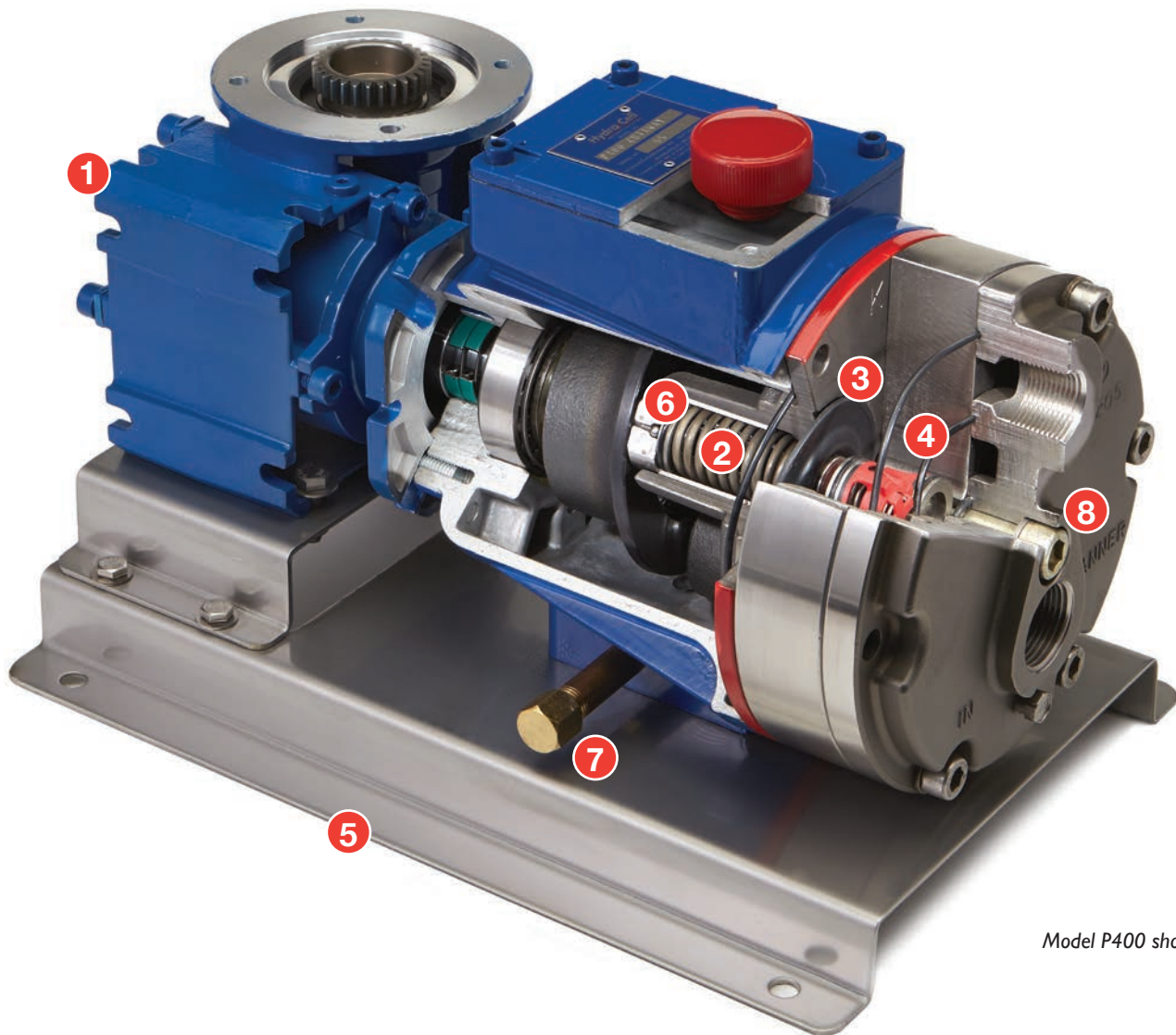

Model P400 shown

- 1 More Accurate**  
No manual stroke adjustment to cause inaccuracies, potential leakage and operator error.
- 2 Optimal Precision**  
Full stroke - every stroke.
- 3 Linear Flow**  
Multiple diaphragms reduce pulsations and acceleration losses and provide smooth, accurate injection of fluids.
- 4 Variety of Flows & Pressures**  
Same plunger, liquid end and diaphragm size.
- 5 Space-Saving**  
Significantly smaller footprint than comparably-rated metering pumps.
- 6 Greater Repeatability**  
Replenishment valve in piston assembly ensures optimum actuating oil on every stroke for continuous accuracy.
- 7 Easy Maintenance**  
Simple, neat drain plug for oil changes.
- 8 Less Chance of Entrapped Air**  
Porting is larger than normal to eliminate common out-gassing metering problems.

**1 Separate Gearbox**  
Enables versatility in changing applications and prevents cross-contamination of actuating hydraulic oil.

**2 Versatile Motor Adapter**  
Makes it easier to install or replace motors. (Variety of NEMA & IEC motor frames available.)

**3 Inherent Simplicity**  
Lowers acquisition costs, reduces maintenance costs, and minimizes labor costs.

**4 Extensive Choice of Materials**  
Choice of diaphragm, check valve, and liquid end materials allows pumps to operate in a wider range of applications.

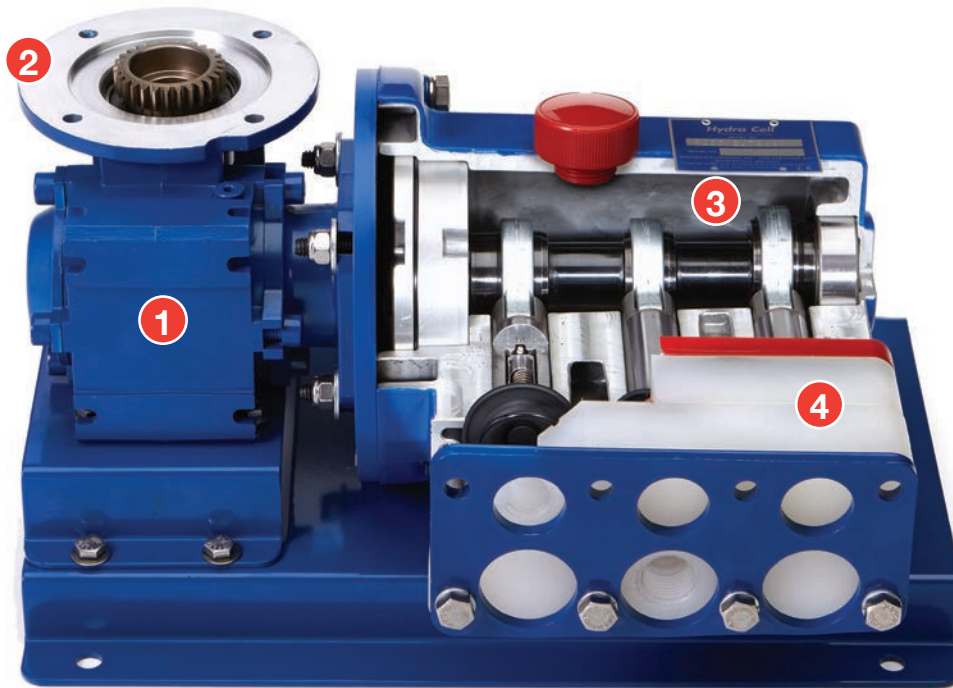

*Model P200 shown*

**1 Spring-Loaded, Horizontal Disk Check Valves**

Designed for superior handling of particulates and viscous fluids compared to floating, vertical ball-style check valves.

**2 Multiple Diaphragms**

Provide smooth, almost pulseless performance with linear flow, compared to the “slugs” created by conventional metering pumps.

**3 Robust Construction**

Delivers long-lasting, durable operation in the toughest industrial and processing environments.

**4 Lubricated Ball Bearings**

Ensure optimal pump life.

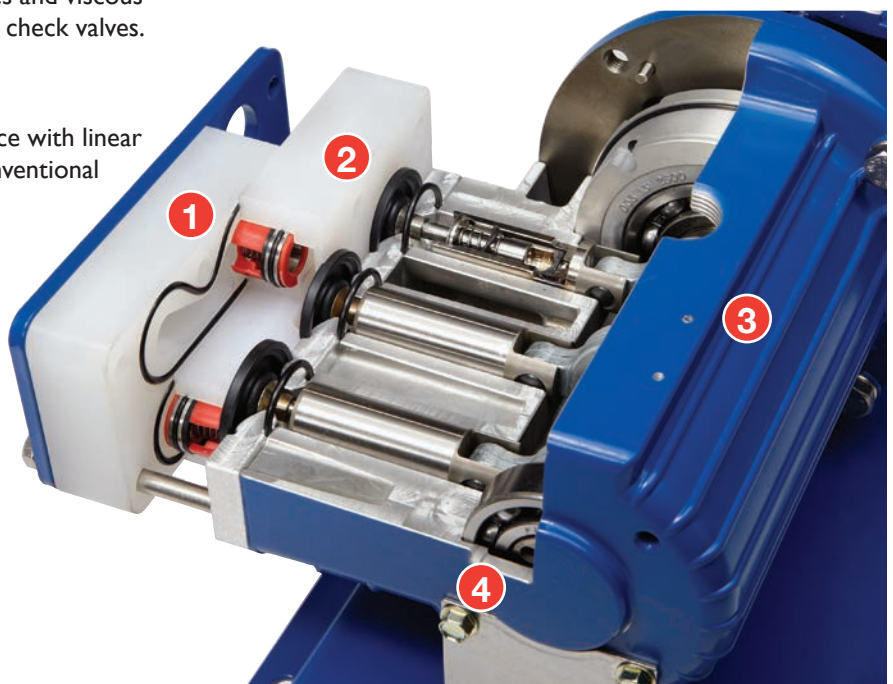

# Hydra-Cell® Metering Performance Standards

## Metering Pumps that Exceed API 675 Performance Standards

In 1994, the American Petroleum Institute (API) adapted its Standard 675 to stipulate performance characteristics for controlled-volume, positive displacement pumps. Although revised in 2010, and again in 2012, API 675 primarily defined metering pumps using mechanical stroke adjustment.

Hydra-Cell Metering Solutions meet or exceed API 675 performance standards by using electronic flow control to improve accuracy and a multiple-diaphragm design to reduce pulsations. A replenishment valve in every piston assembly ensures optimal actuating oil for continuous accuracy and greater repeatability. Used in precise metering, dosing, injection, and mixing applications, Hydra-Cell pumps provide an economical alternative to conventional metering pumps.

## Operational Data for Testing

Pump Configuration:	P300NRGSS015S
Reducer:	15:1
Pressure:	1500 psi (103 bar)
Actuating Oil:	10W-30 Hydra-Oil
Ambient Temperature:	71.5°F (21.9°C)
Pumped Fluid:	Water @72°F (22.2°C)
Gravity Feed:	1-to-3 Feet ( 0.3-to-0.91 Meters) Positive Head
Franklin IMDS Motor:	240-2400 rpm 1 hp (0.75 kW)

### Accuracy - Performance at a Set Point

For continuous metering applications, Hydra-Cell metering pumps provide precise steady-state accuracy of  $\pm 1\%$  or better.

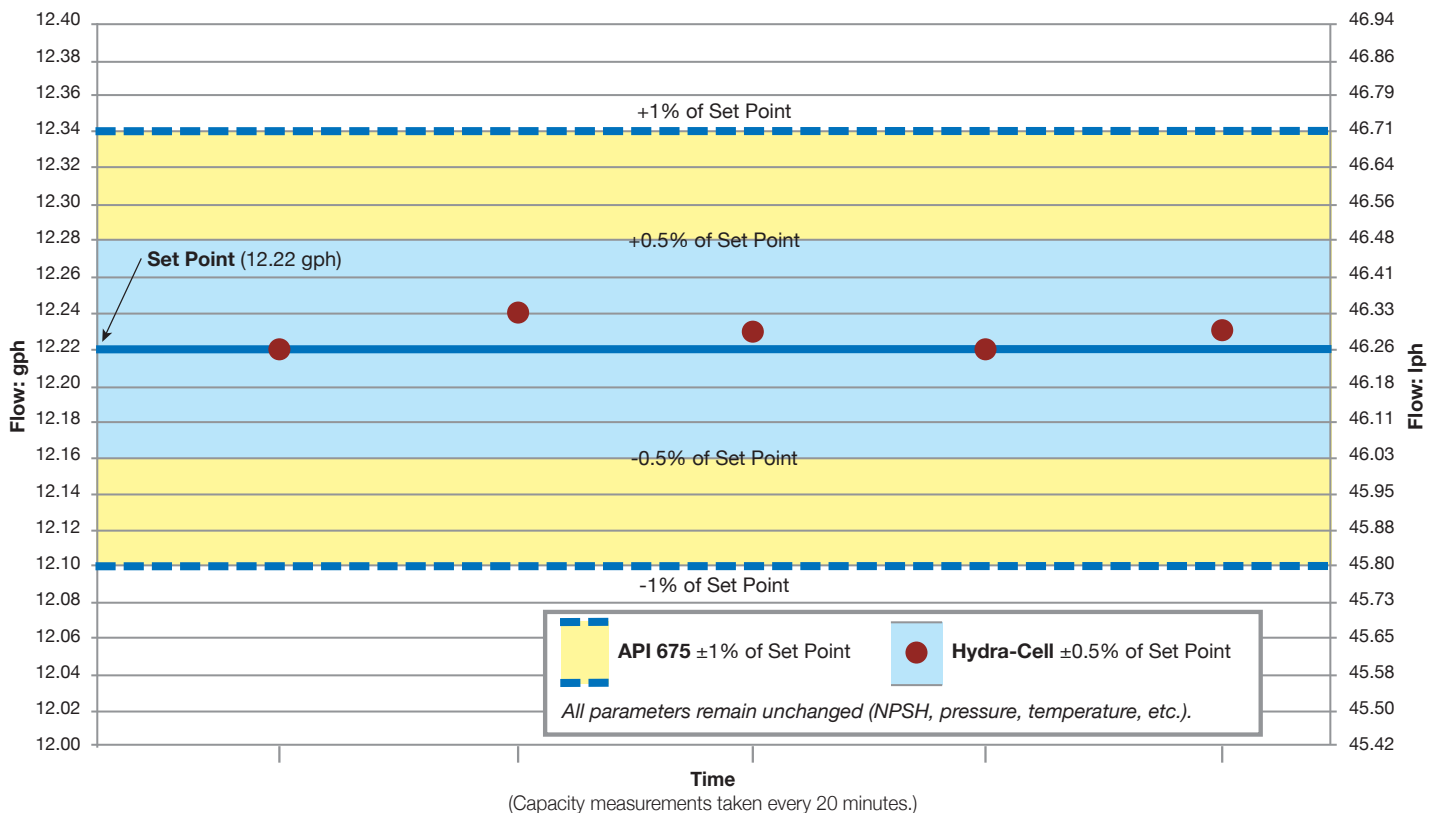

### Linearity - Speed/Flow Rate Relationship

For smooth, virtually pulse-less performance, Hydra-Cell metering pumps provide linear flow within  $\pm 3\%$  or better.

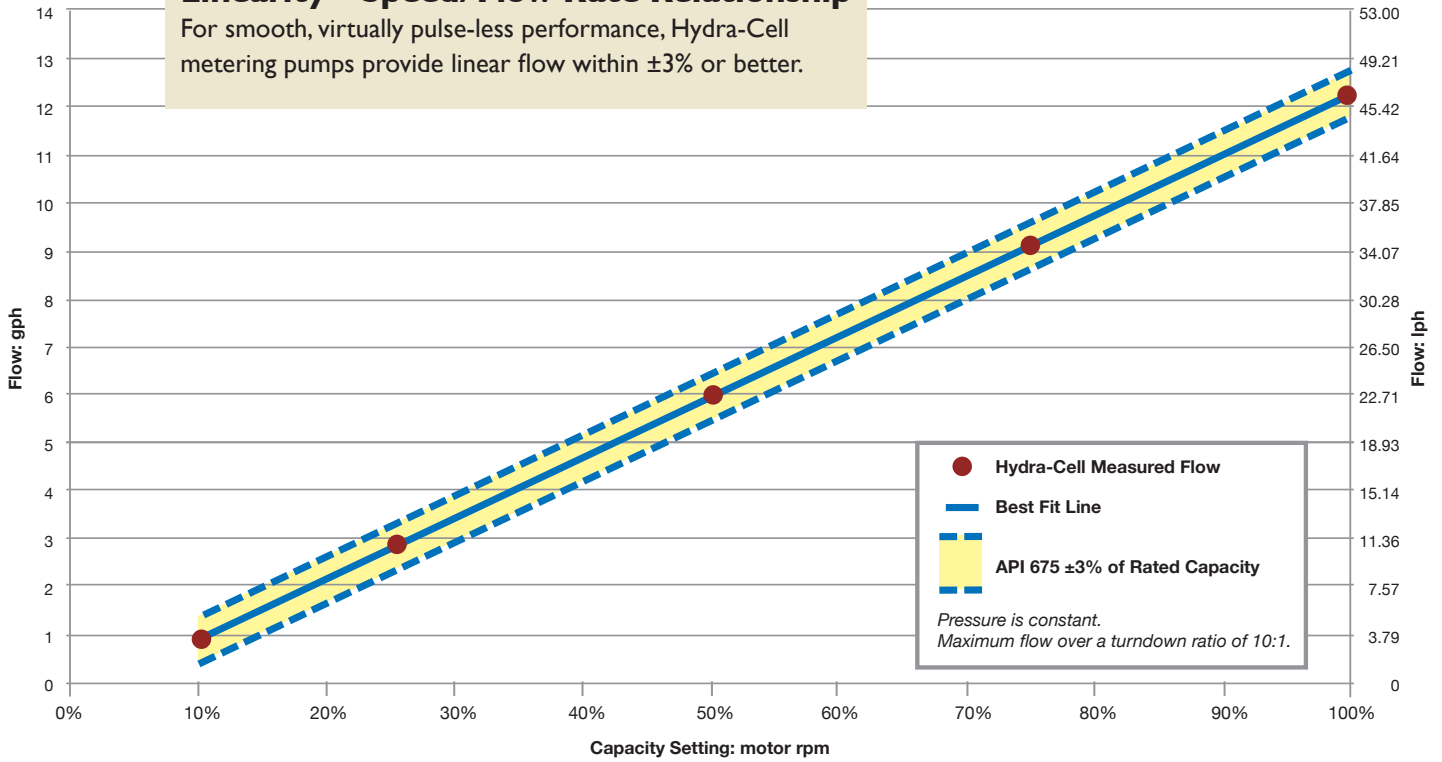

Best Fit Line is drawn through the Measured Flow data points, taken at 100%, 75%, 50%, 25%, and 10% of Rated Capacity (12.25 gph).

### Repeatability - Return to Set Conditions

Hydra-Cell metering pumps always return to  $\pm 3\%$  or better of a set point condition after deviation (1200 rpm tested below).

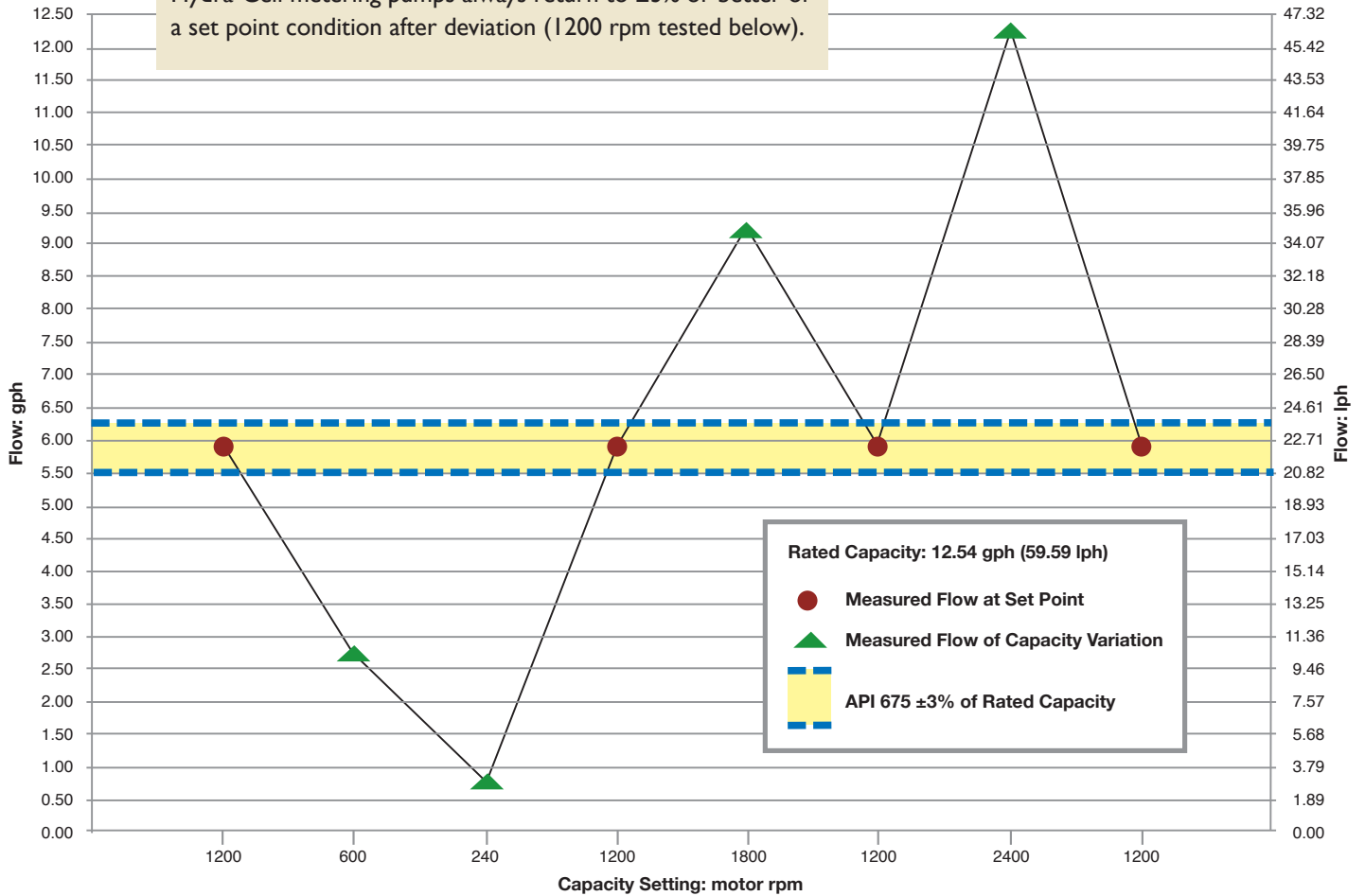

# Hydra-Cell® Metering Pump Selection



**P100**

Page 19



**P200**

Page 23

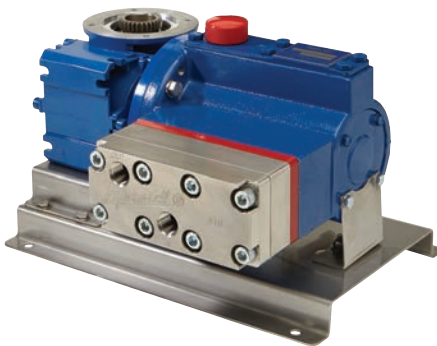

**P300**

Page 27

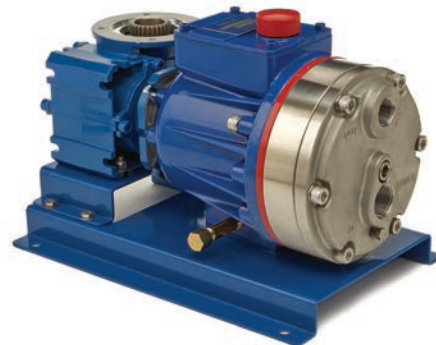

**P400**

Page 31

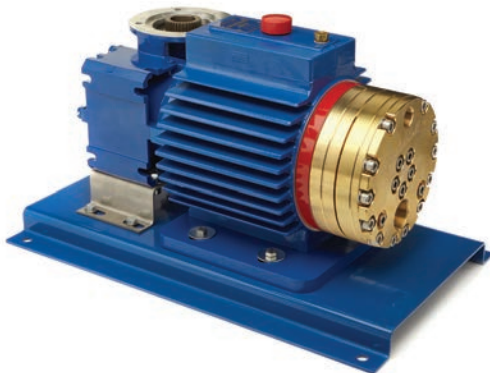

**P500**

Page 35

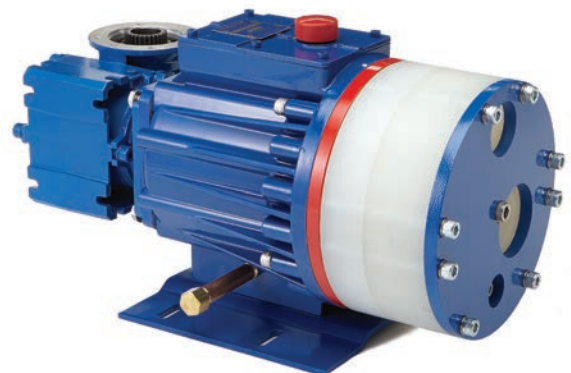

**P600**

Page 39

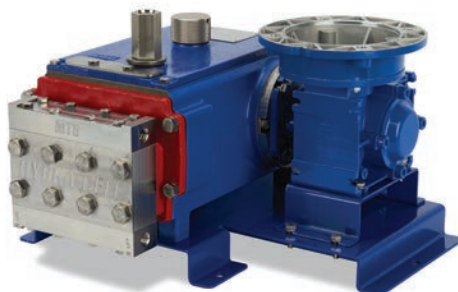

**MT8**

Page 43

# Hydra-Cell® Flow Capacities and Pressure Ratings

## Maximum Flow Rates (gph) with 1800 rpm Motor Speed

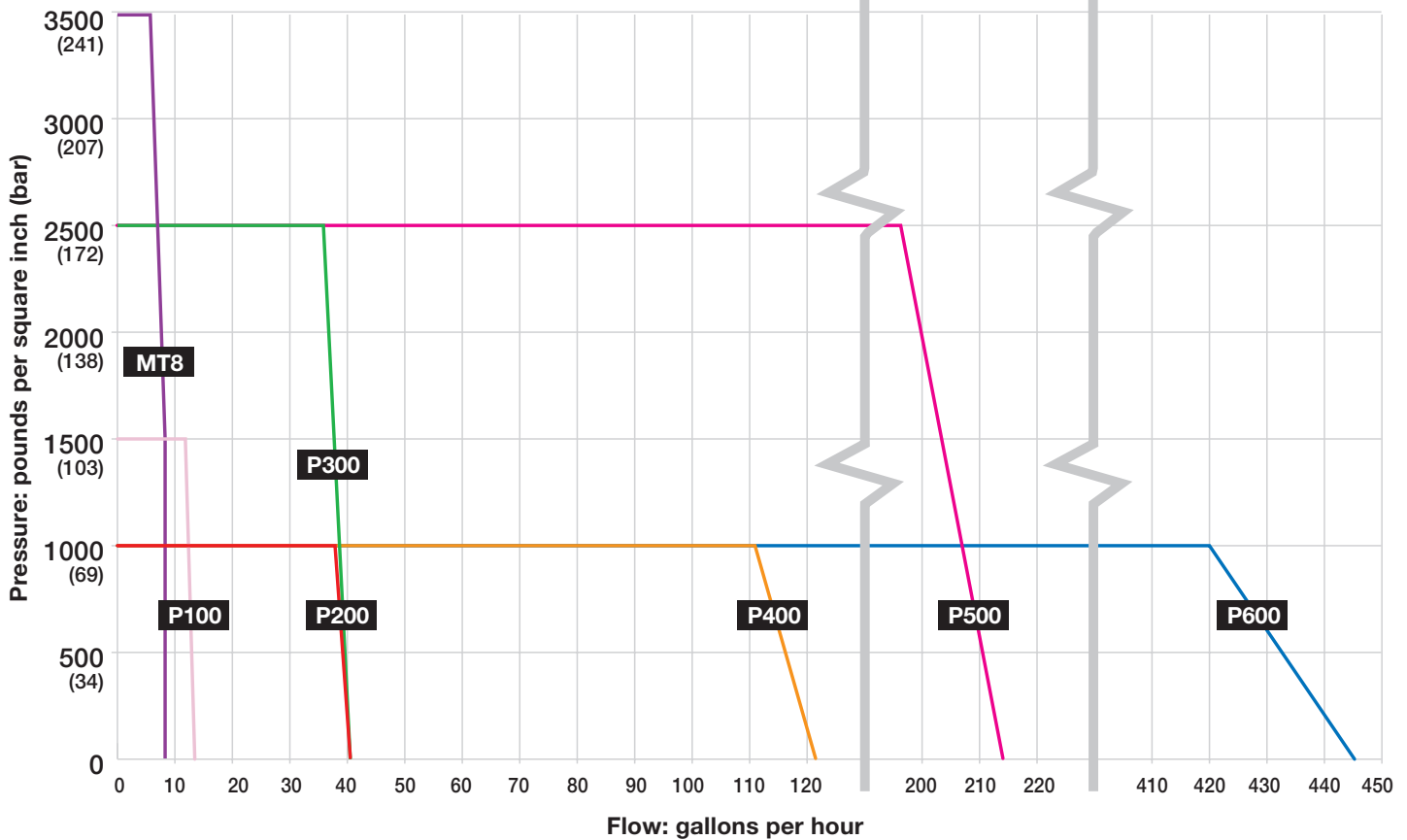

Flows shown in the graph above and listed in the chart below for each metering pump are based upon lab testing of multiple pumps. However, flows listed are approximate values and pumps must be calibrated once installed into any system. Flow variations will occur, but calibration will ensure proper pump performance.

## Specifications for 1800 & 3600 rpm Motor Speed

Model <sup>1</sup>	Motor Speed rpm	Max Capacity gph	Max Discharge Pressure psi (bar)		Max Operating Temperature F (C) <sup>3</sup>		Max Inlet Pressure psi (bar)
			Non-metallic <sup>2</sup>	Metallic	Non-metallic	Metallic	
MT8	1800	8.0	350 (24)	3500 (241)	140° (60°)	250° (121°)	500 (34) <sup>4</sup>
P100	1800	13.5	350 (24)	1500 (103)	140° (60°)	250° (121°)	250 (17)
P100	3600	27.0	350 (24)	1500 (103)	140° (60°)	250° (121°)	250 (17)
P200	1800	40.5	350 (24)	1000 (69)	140° (60°)	250° (121°)	250 (17)
P200	3600	81.0	350 (24)	1000 (69)	140° (60°)	250° (121°)	250 (17)
P300	1800	40.6	N/A	2500 (172)	N/A	250° (121°)	500 (34)
P300	3600	81.4	N/A	2500 (172)	N/A	250° (121°)	500 (34)
P400	1800	121.1	350 (24)	1000 (69)	140° (60°)	250° (121°)	250 (17)
P400	3600	242.8	350 (24)	1000 (69)	140° (60°)	250° (121°)	250 (17)
P500	1800	212.8	N/A	2500 (172)	N/A	250° (121°)	500 (34)
P500	3600	425.9	N/A	2500 (172)	N/A	250° (121°)	500 (34)
P600	1800	444.8	350 (24)	1000 (69)	140° (60°)	250° (121°)	250 (17)
P600	3600	890.3	350 (24)	1000 (69)	140° (60°)	250° (121°)	250 (17)

<sup>1</sup> Ratings are for X-cam design.

<sup>2</sup> 350 psi (24 bar) maximum with PVDF or PVC (MT8 only) liquid ends; 250 psi (17 bar) maximum with Polypropylene liquid end (P Series only).

<sup>3</sup> Consult factory for correct component selection for temperatures from 160°F (71°C) to 250°F (121°C).

<sup>4</sup> 300 psi (20 bar) maximum with non-metallic MT8 models.

# Hydra-Cell® Flow Capacities and Pressure Ratings

## Maximum Flow Rates (lph) with 1500 rpm Motor Speed

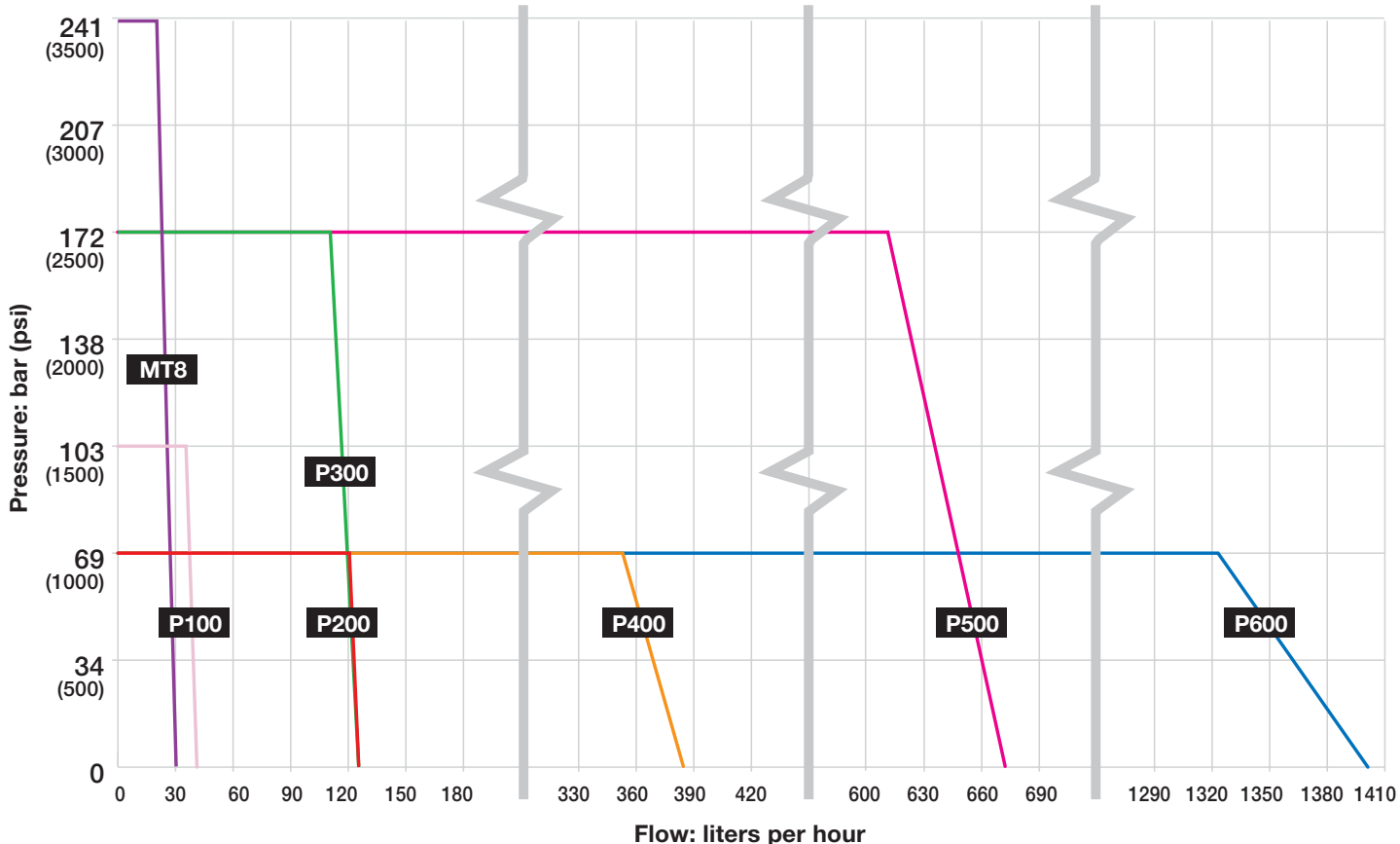

Flows shown in the graph above and listed in the chart below for each metering pump are based upon lab testing of multiple pumps. However, flows listed are approximate values and pumps must be calibrated once installed into any system. Flow variations will occur, but calibration will ensure proper pump performance.

## Specifications for 1500 & 3000 rpm Motor Speed

Model <sup>1</sup>	Motor Speed rpm	Max Capacity lph	Max Discharge Pressure bar (psi)		Max Operating Temperature C (F) <sup>3</sup>		Max Inlet Pressure bar (psi)
			Non-metallic <sup>2</sup>	Metallic	Non-metallic	Metallic	
MT8	1500	30.1	24 (350)	241 (3500)	60° (140°)	121° (250°)	34 (500) <sup>4</sup>
P100	1500	42.4	24 (350)	103 (1500)	60° (140°)	121° (250°)	17 (250)
P100	3000	85.0	24 (350)	103 (1500)	60° (140°)	121° (250°)	17 (250)
P200	1500	127.7	24 (350)	69 (1000)	60° (140°)	121° (250°)	17 (250)
P200	3000	255.4	24 (350)	69 (1000)	60° (140°)	121° (250°)	17 (250)
P300	1500	128.2	N/A	172 (2500)	N/A	121° (250°)	34 (500)
P300	3000	256.8	N/A	172 (2500)	N/A	121° (250°)	34 (500)
P400	1500	382.1	24 (350)	69 (1000)	60° (140°)	121° (250°)	17 (250)
P400	3000	765.9	24 (350)	69 (1000)	60° (140°)	121° (250°)	17 (250)
P500	1500	671.4	N/A	172 (2500)	N/A	121° (250°)	34 (500)
P500	3000	1343.5	N/A	172 (2500)	N/A	121° (250°)	34 (500)
P600	1500	1403.0	24 (350)	69 (1000)	60° (140°)	121° (250°)	17 (250)
P600	3000	2808.0	24 (350)	69 (1000)	60° (140°)	121° (250°)	17 (250)

<sup>1</sup> Ratings are for X-cam design.

<sup>2</sup> 24 bar (350 psi) maximum with PVDF or PVC (MT8 only) liquid ends; 17 bar (250 psi) maximum with Polypropylene liquid end (P Series only).

<sup>3</sup> Consult factory for correct component selection for temperatures from 71°C (160°F) to 121°C (250°F).

<sup>4</sup> 20 bar (300 psi) maximum with non-metallic MT8 models.

# PI00 Series

Maximum Flow Rate: 27.0 gph (85.0 lph)  
 Maximum Pressure: 1500 psi (103 bar) for Metallic Pump Heads  
 350 psi (24 bar) for Non-metallic Pump Heads

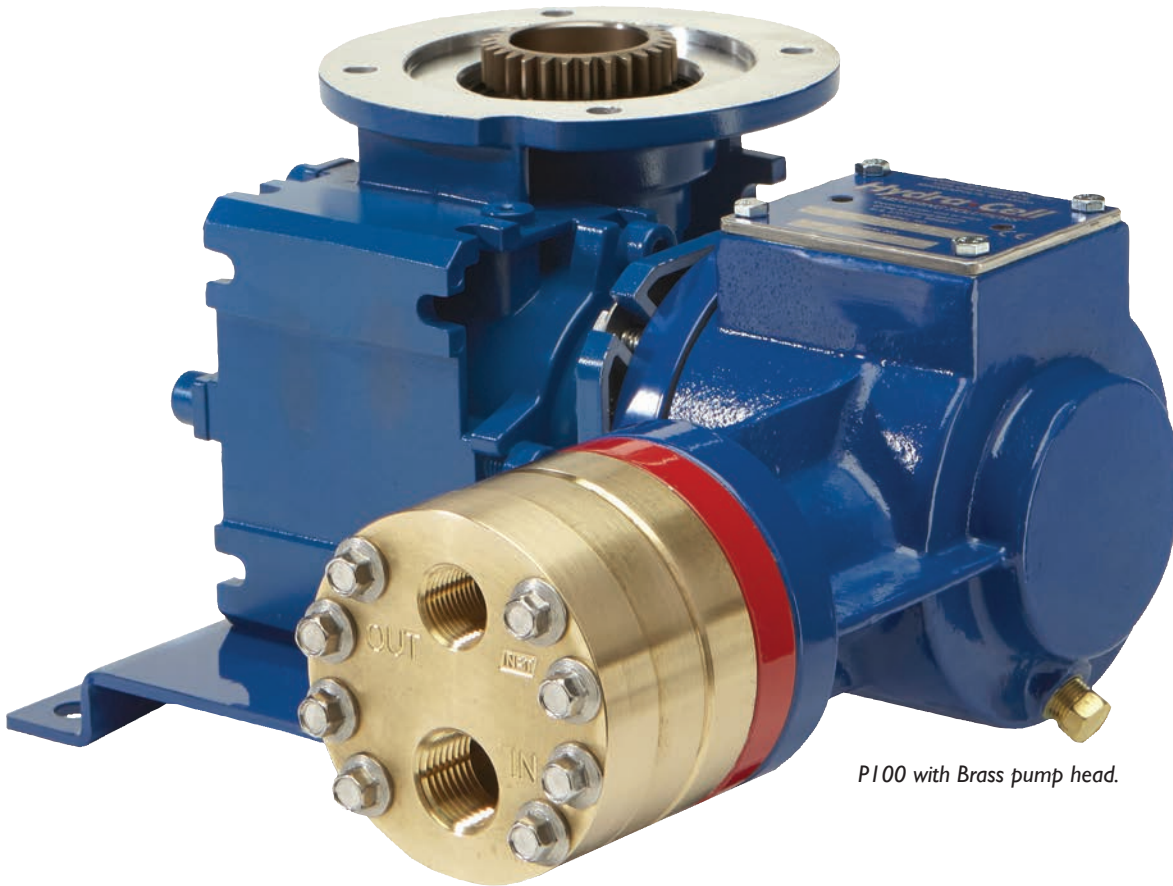

PI00 with Brass pump head.

## Pump Data

Diaphragms per Liquid End	1
Flow Control	Electronic variable speed drive
Maximum Discharge Pressure	
Metallic Heads:	1500 psi (103 bar)
Non-metallic Heads:	PVDF- 350 psi (24 bar)
	Polypropylene- 250 psi (17 bar)
Maximum Inlet Pressure	250 psi (17 bar)
Maximum Operating Temperature	
	<i>Consult factory for correct metallic head component selection for temperatures from 160°F (71°C) to 250°F (121°C).</i>
Metallic Heads:	250°F (121°C)
Non-metallic Heads:	140°F (60°C)
Maximum Solids Size	200 microns
Inlet Port	1/2 inch NPT or BSPT
Discharge Port	3/8 inch NPT or BSPT

Shaft Rotation	Bi-directional
Oil Capacity	0.125 US quarts (0.12 liters)
Weight (less motor)	
Metallic Heads:	21.3 lbs (9.7 kg)
Non-metallic Heads:	19.2 lbs (8.7 kg)
Dimensions (less motor)	
	<i>For NEMA 56 motor frames only; see page 21 for other motor frame sizes.</i>
Metallic Heads:	9.93" W x 11.36" D x 6.92" H (252.2 mm W x 287.4 mm D x 175.8 mm H)
Non-metallic Heads:	9.93" W x 11.61" D x 6.92" H (252.2 mm W x 294.9 mm D x 175.8 mm H)

# PI00 Series Performance

## Maximum Flow (gph) at Designated Pressure (psi)

All Pumps (gph)		Metallic Pump Heads Only (gph)			Pump rpm	Gear Ratio	Motor rpm
100 psi	250 psi	500 psi	1000 psi	1500 psi			
1.086	1.077	1.058	1.015	0.981	30	60:1	1800
1.316	1.300	1.273	1.220	1.184	36	50:1	
1.630	1.628	1.607	1.535	1.492	45	40:1	
2.192	2.182	2.148	2.056	2.000	60	30:1	
2.643	2.626	2.582	2.473	2.405	72	25:1	
3.318	3.291	3.232	3.099	3.014	90	20:1	
4.444	4.400	4.316	4.141	4.028	120	15:1	
6.695	6.618	6.483	6.226	6.057	180	10:1	
8.947	8.836	8.651	8.311	8.085	240	7.5:1	
13.45	13.27	12.99	12.48	12.14	360	5:1	
17.95	17.71	17.32	16.65	16.20	480	7.5:1	3600
26.96	26.58	25.99	24.99	24.31	720	5:1	

### Required Motor hp

1/2	3/4	1
-----	-----	---

## Maximum Flow (lph) at Designated Pressure (bar)

All Pumps (lph)		Metallic Pump Heads Only (lph)			Pump rpm	Gear Ratio	Motor rpm
7 bar	17 bar	34 bar	69 bar	103 bar			
3.425	3.396	3.337	3.203	3.095	25	60:1	1500
4.150	4.102	4.016	3.850	3.735	30	50:1	
5.140	5.135	5.068	4.841	4.708	37.5	40:1	
6.916	6.884	6.777	6.486	6.307	50	30:1	
8.336	8.283	8.145	7.801	7.587	60	25:1	
10.47	10.38	10.20	9.774	9.507	75	20:1	
14.02	13.88	13.61	13.06	12.71	100	15:1	
21.12	20.88	20.45	19.64	19.11	150	10:1	
28.22	27.87	27.29	26.22	25.50	200	7.5:1	
42.43	41.87	40.96	39.37	38.30	300	5:1	
56.63	55.86	54.64	52.53	51.10	400	7.5:1	3000
85.04	83.85	81.98	78.84	76.70	600	5:1	

### Required Motor kW

0.18	0.25	0.37	0.55
------	------	------	------

# PI00 Series Representative Drawings

## Metallic and Non-metallic Pump Heads Inches (mm)

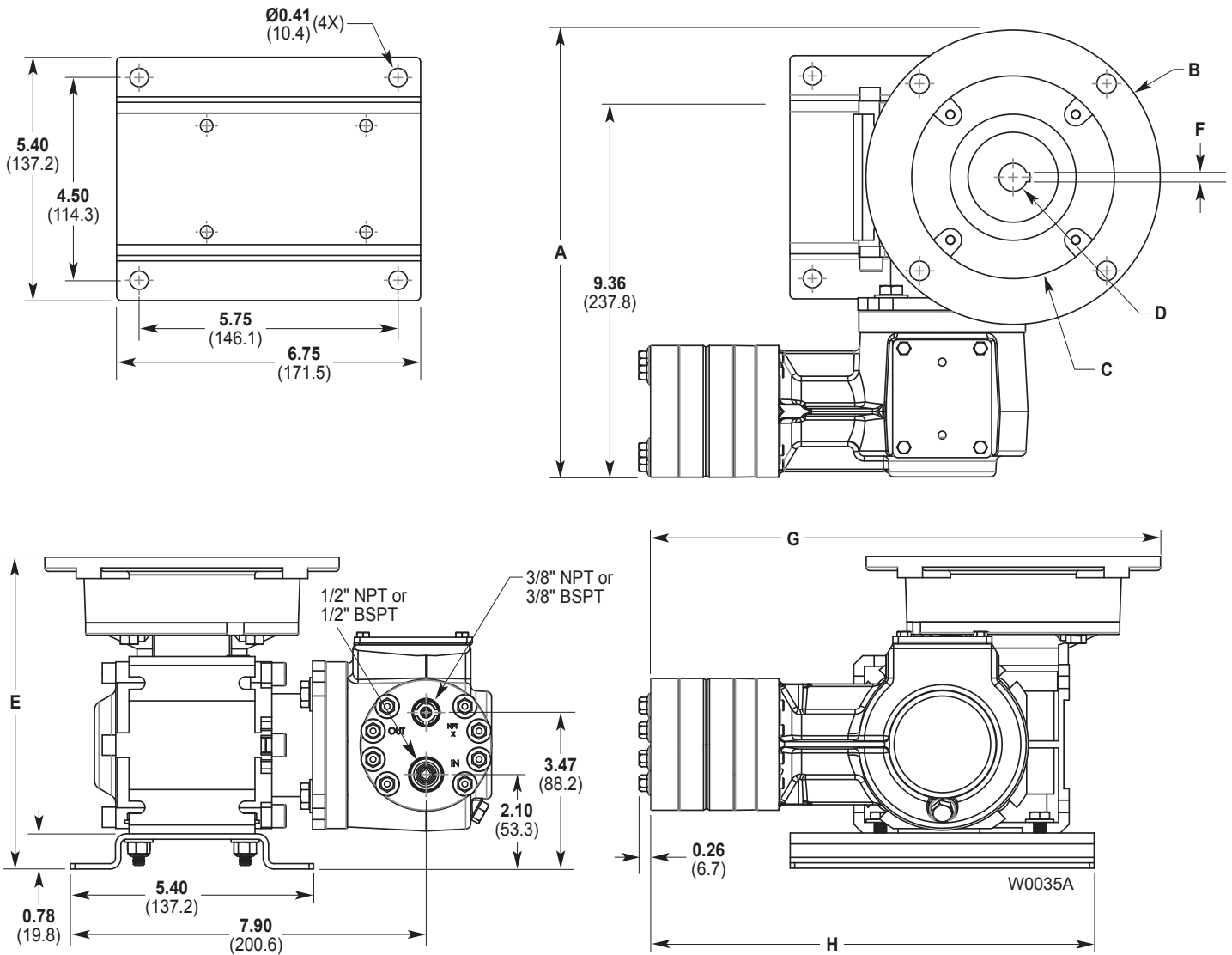

## Dimensions: Inches (mm)

Input Frame Size	A	B	C	D	E	F (Square Key)	G		H	
							Metallic Pump Head	Plastic Pump Head	Metallic Pump Head	Plastic Pump Head
NEMA 56C	9.93 (252.2)	$\text{Ø} 6.54$ (Ø 166)	$\text{Ø} 4.50$ (Ø 114.3)	$\text{Ø} .62$ (Ø 15.7)	6.92 (175.8)	0.187 (4.75)	11.32 (287.5)	11.61 (294.9)	9.84 (250)	10.09 (256.3)
IEC 63 B5	9.42 (239)	$\text{Ø} 5.51$ (Ø 140)	$\text{Ø} 3.74$ (Ø 95)	$\text{Ø} .43$ (Ø 11)	6.74 (171.3)	0.157 (4)	10.80 (274.3)	11.09 (281.7)	9.84 (250)	10.09 (256.3)
IEC 71 B5	9.81 (249.2)	$\text{Ø} 6.30$ (Ø 160)	$\text{Ø} 4.33$ (Ø 110)	$\text{Ø} .55$ (Ø 14)	6.74 (171.3)	0.196 (5)	11.20 (284.5)	11.49 (291.8)	9.84 (250)	10.09 (256.3)
IEC 80 B5	10.59 (260)	$\text{Ø} 7.87$ (Ø 200)	$\text{Ø} 5.12$ (Ø 130)	$\text{Ø} .75$ (Ø 19)	6.74 (171.3)	0.237 (6)	11.98 (304.29)	12.27 (311.6)	9.84 (250)	10.09 (256.3)

# PI00 Series How to Order

1	2	3	4	5	6	7	8	9	10	11	12	13
P	1	0	0									

A complete pump order number contains 13 digits based on the specified pump materials listed below.

## Pump Configuration (Digits 1-4)

**P100** For all P100 Pumps (Non Kel-Cell)

## Pump Version (Digit 5)

**N** NPT Ports (NEMA motors only)  
**M** BSPT Ports (IEC motors only)  
**X** ATEX BSPT Ports (IEC motors only)

## Pump Head / Retainer Material (Digit 6)

**B** Brass / Hastelloy C  
**M** PVDF / PVDF  
**P** Polypropylene / Polypropylene  
**S** 316L Stainless Steel / Hastelloy C  
**T** Hastelloy C / Hastelloy C

## Diaphragm & O-ring Material / Oil (Digit 7)▲

**A** Atlas / PTFE O-ring (Synthetic oil)  
**E** EPDM (EPDM-compatible oil)  
**X** FKM (Synthetic oil)  
**J** PTFE (Food-contact oil)  
*(Note: PTFE diaphragms require a minimum suction pressure of 15 psi/1 bar.)*  
**P** Neoprene (Synthetic oil)  
**T** Buna-N (Synthetic oil)

▲ See price list for different actuating oils available with these materials.

## Check Valve Material (Digits 8-9)

### (Valve Spring / Valve Seat / Valve)

**SS** Elgiloy / 316L SST / Nitronic 50  
**TT** Hastelloy C / Hastelloy C / Hastelloy C  
**SC** Elgiloy / Ceramic / Ceramic  
**TC** Hastelloy C / Ceramic / Ceramic

## Gearbox Ratio (Digits 10-12) NEMA Motors

**060** 60:1 (56C Motor Frame)  
**050** 50:1 (56C Motor Frame)  
**040** 40:1 (56C Motor Frame)  
**030** 30:1 (56C Motor Frame)  
**025** 25:1 (56C Motor Frame)  
**020** 20:1 (56C Motor Frame)  
**015** 15:1 (56C Motor Frame)  
**010** 10:1 (56C Motor Frame)  
**007** 7.5:1 (56C Motor Frame)  
**005** 5:1 (56C Motor Frame)  
**A05** 5:1 (143/145TC Motor Frame)

## Gearbox Ratio (Digits 10-12) IEC Motors

**060** 60:1 (63 B5 Motor Frame)  
**050** 50:1 (63 B5 Motor Frame)  
**A40** 40:1 (71 B5 Motor Frame)  
**030** 30:1 (63 B5 Motor Frame)  
**A30** 30:1 (71 B5 Motor Frame)  
**A25** 25:1 (71 B5 Motor Frame)  
**A20** 20:1 (71 B5 Motor Frame)  
**A15** 15:1 (71 B5 Motor Frame)  
**A10** 10:1 (71 B5 Motor Frame)  
**A07** 7.5:1 (71 B5 Motor Frame)  
**B07** 7.5:1 (80 B5 Motor Frame)  
**A05** 5:1 (71 B5 Motor Frame)  
**B05** 5:1 (80 B5 Motor Frame)

## Base Plate (Digit 13)

**C** Carbon Steel (Epoxy painted)  
**S** 304 Stainless Steel



PI00 with Polypropylene pump head.



PI00 with Stainless Steel pump head.

# P200 Series

Maximum Flow Rate: 81.0 gph (255.4 lph)  
 Maximum Pressure: 1000 psi (69 bar) for Metallic Pump Heads  
 350 psi (24 bar) for Non-metallic Pump Heads



P200 with Polypropylene pump head.

## Pump Data

Diaphragms per Liquid End	3
Flow Control	Electronic variable speed drive
Maximum Discharge Pressure	
Metallic Heads:	1000 psi (69 bar)
Non-metallic Heads:	PVDF- 350 psi (24 bar)
	Polypropylene- 250 psi (17 bar)
Maximum Inlet Pressure	250 psi (17 bar)
Maximum Operating Temperature	
<i>Consult factory for correct metallic head component selection for temperatures from 160°F (71°C) to 250°F (121°C).</i>	
Metallic Heads:	250°F (121°C)
Non-metallic Heads:	140°F (60°C)
Maximum Solids Size	200 microns
Inlet Port	1/2 inch NPT or BSPT
Discharge Port	3/8 inch NPT or BSPT

Shaft Rotation	Bi-directional
Oil Capacity	1.0 US quarts (0.95 liters)
Weight (less motor)	
Metallic Heads:	41.8 lbs (19.0 kg)
Non-metallic Heads:	32.8 lbs (14.9 kg)
Dimensions (less motor)	
<i>For NEMA 56 motor frames only; see page 25 for other motor frame sizes.</i>	
Metallic Heads:	15.59" W x 11.68" D x 8.97" H (396.1 mm W x 296.7 mm D x 227.8 mm H)
Non-metallic Heads:	15.59" W x 12.06" D x 8.97" H (396.1 mm W x 306.3 mm D x 227.8 mm H)

# P200 Series Performance

## Maximum Flow (gph) at Designated Pressure (psi)

All Pumps (gph)		Metallic Pump Heads Only (gph)		Pump rpm	Gear Ratio	Motor rpm
100 psi	250 psi	500 psi	1000 psi			
3.378	3.321	3.249	3.128	30	60:1	1800
4.059	3.994	3.911	3.776	36	50:1	
5.072	5.015	4.908	4.748	45	40:1	
6.758	6.686	6.555	6.353	60	30:1	
8.107	8.022	7.873	7.637	72	25:1	
10.130	10.027	9.849	9.563	90	20:1	
13.503	13.369	13.14	12.77	120	15:1	
20.248	20.052	19.73	19.19	180	10:1	
26.993	26.735	26.32	25.62	240	7.5:1	
40.483	40.101	39.49	38.46	360	5:1	
53.97	53.47	52.66	51.30	480	7.5:1	3600
80.95	80.20	79.01	76.98	720	5:1	

### Required Motor hp

1/4	1/2	3/4	1	1-1/2
-----	-----	-----	---	-------

## Maximum Flow (lph) at Designated Pressure (bar)

All Pumps (lph)		Metallic Pump Heads Only (lph)		Pump rpm	Gear Ratio	Motor rpm
7 bar	17 bar	34 bar	69 bar			
10.65	10.48	10.25	9.868	25	60:1	1500
12.81	12.60	12.34	11.91	30	50:1	
16.00	15.82	15.48	14.98	37.5	40:1	
21.32	21.09	20.68	20.04	50	30:1	
25.57	25.31	24.83	24.09	60	25:1	
31.96	31.63	31.07	30.17	75	20:1	
42.59	42.17	41.46	40.29	100	15:1	
63.87	63.25	62.23	60.55	150	10:1	
85.15	84.34	83.01	80.80	200	7.5:1	
127.7	126.5	124.6	121.3	300	5:1	
170.3	168.7	166.1	161.8	400	7.5:1	3000
255.4	253.0	249.2	242.8	600	5:1	

### Required Motor kW

0.18	0.25	0.37	0.55	0.75
------	------	------	------	------

# P200 Series Representative Drawings

## Metallic and Non-metallic Pump Heads Inches (mm)

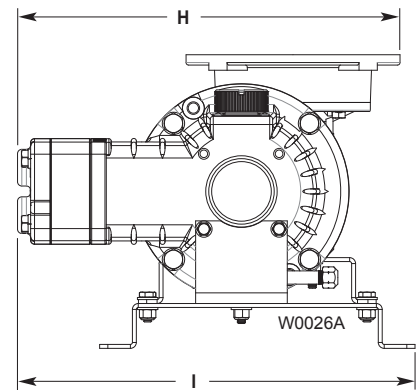
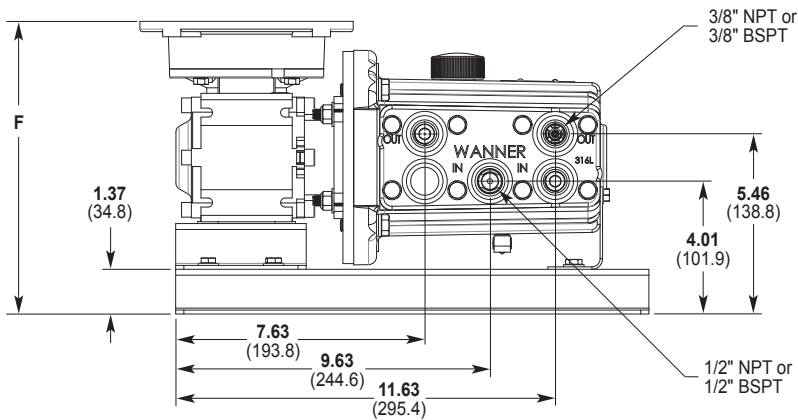
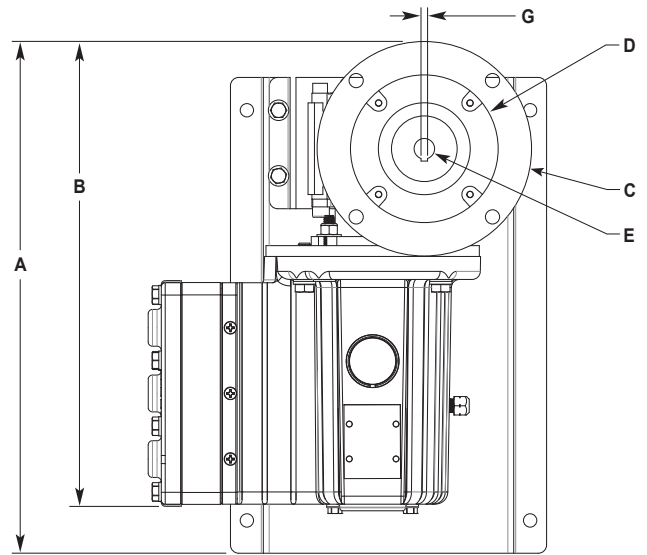
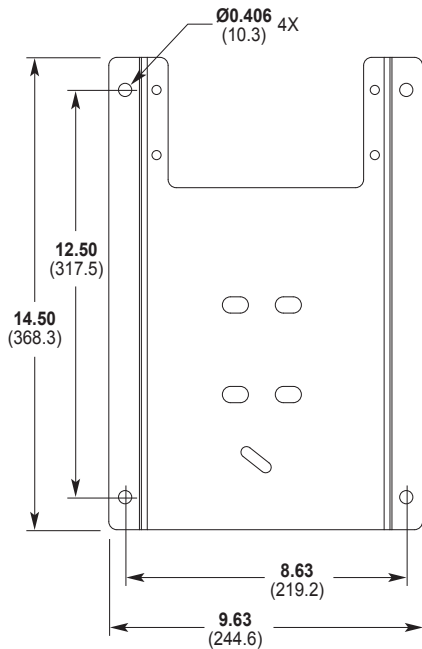

## Dimensions: Inches (mm)

Input Frame Size	A	B	C	D	E	F	G (Square Key)	H		I	
								Metallic Pump Head	Plastic Pump Head	Metallic Pump Head	Plastic Pump Head
NEMA 56C	15.59 (396.1)	14.17 (359.8)	Ø 6.54 (Ø 166)	Ø 4.50 (Ø 114.3)	Ø 0.62 (Ø 15.7)	8.97 (227.8)	0.187 (4.7)	11.68 (296.7)	12.06 (306.3)	12.14 (308.3)	12.51 (317.75)
NEMA 143/145TC	17.53 (445.3)	16.04 (407.4)	Ø 6.54 (Ø 166.1)	Ø 4.50 (Ø 114.3)	Ø 0.88 (Ø 22.3)	11.09 (281.7)	0.187 (4.7)	11.68 (296.7)	12.06 (306.3)	12.14 (308.3)	12.51 (317.75)
IEC 63 B5	15.08 (383)	13.65 (346.7)	Ø 5.51 (Ø 140)	Ø 3.74 (Ø 95)	Ø 0.43 (Ø 11)	8.80 (223.5)	0.157 (4)	11.17 (283.7)	11.55 (293.4)	12.14 (308.3)	12.51 (317.75)
IEC 71 B5	15.48 (393.1)	14.05 (356.7)	Ø 6.30 (Ø 160)	Ø 4.33 (Ø 110)	Ø 0.55 (Ø 14)	8.80 (223.5)	0.196 (5)	11.56 (293.6)	11.94 (303.3)	12.14 (308.3)	12.51 (317.75)
IEC 80 B5	16.26 (413)	14.835 (376.7)	Ø 7.87 (Ø 200)	Ø 5.12 (Ø 130)	Ø 0.75 (Ø 19)	8.80 (223.5)	0.236 (6)	12.35 (313.7)	12.72 (323)	12.14 (308.3)	12.51 (317.75)
IEC 90 B5	16.26 (413)	14.835 (376.7)	Ø 7.87 (Ø 200)	Ø 5.12 (Ø 130)	Ø 0.94 (Ø 24)	9.24 (234.7)	0.314 (8)	12.35 (313.7)	12.72 (323)	12.14 (308.3)	12.51 (317.75)

# P200 Series How to Order

1	2	3	4	5	6	7	8	9	10	11	12	13
P	2	0	0									

A complete pump order number contains 13 digits based on the specified pump materials listed below.

## Pump Configuration (Digits 1-4)

**P200** For all P200 Pumps (Non Kel-Cell)

## Pump Version (Digit 5)

**N** NPT Ports (NEMA motors only)  
**M** BSPT Ports (IEC motors only)  
**X** ATEX BSPT Ports (IEC motors only)

## Pump Head / Retainer Material (Digit 6)

**B** Brass / Hastelloy C  
**M** PVDF / PVDF  
**P** Polypropylene / Polypropylene  
**S** 316L Stainless Steel / Hastelloy C  
**T** Hastelloy CW12MW / Hastelloy C

## Diaphragm & O-ring Material / Oil (Digit 7)▲

**A** Aflas / PTFE O-rings (Synthetic oil)  
**M** Aflas / PTFE O-rings & FKM drive case elastomers (Mesamoll oil)  
**E** EPDM (EPDM-compatible oil)  
**X** FKM (Synthetic oil)  
**J** PTFE (Food-contact oil)  
**P** Neoprene (Standard oil)  
**T** Buna-N (Standard oil)

▲ See price list for different actuating oils available with these materials.

## Check Valve Material (Digits 8-9)

### (Valve Spring / Valve Seat / Valve)

**SS** Elgiloy / 316L SST / Nitronic 50  
**TT** Hastelloy C / Hastelloy C / Hastelloy C  
**SC** Elgiloy / Ceramic / Ceramic  
**TC** Hastelloy C / Ceramic / Ceramic

## Gearbox Ratio (Digits 10-12) NEMA Motors

**060** 60:1 (56C Motor Frame)  
**050** 50:1 (56C Motor Frame)  
**040** 40:1 (56C Motor Frame)  
**030** 30:1 (56C Motor Frame)  
**025** 25:1 (56C Motor Frame)  
**020** 20:1 (56C Motor Frame)  
**015** 15:1 (56C Motor Frame)  
**010** 10:1 (56C Motor Frame)  
**007** 7.5:1 (56C Motor Frame)  
**005** 5:1 (56C Motor Frame)  
**A05** 5:1 (143/145TC Motor Frame)

## Gearbox Ratio (Digits 10-12) IEC Motors

**060** 60:1 (63 B5 Motor Frame)  
**050** 50:1 (63 B5 Motor Frame)  
**040** 40:1 (63 B5 Motor Frame)  
**B40** 40:1 (80 B5 Motor Frame)  
**030** 30:1 (63 B5 Motor Frame)  
**B30** 30:1 (80 B5 Motor Frame)  
**025** 25:1 (63 B5 Motor Frame)  
**020** 20:1 (63 B5 Motor Frame)  
**B20** 20:1 (80 B5 Motor Frame)  
**015** 15:1 (63 B5 Motor Frame)  
**A15** 15:1 (71 B5 Motor Frame)  
**010** 10:1 (63 B5 Motor Frame)  
**A10** 10:1 (71 B5 Motor Frame)  
**B10** 10:1 (80 B5 Motor Frame)  
**007** 7.5:1 (63 B5 Motor Frame)  
**A07** 7.5:1 (71 B5 Motor Frame)  
**B07** 7.5:1 (80 B5 Motor Frame)  
**C07** 7.5:1 (90 B5 Motor Frame)  
**005** 5:1 (63 B5 Motor Frame)  
**A05** 5:1 (71 B5 Motor Frame)  
**B05** 5:1 (80 B5 Motor Frame)

## Base Plate (Digit 13)

**C** Carbon Steel (Epoxy painted)  
**S** 304 Stainless Steel



P200 with Stainless Steel pump head.

P200 with Brass pump head.

# P300 Series

Maximum Flow Rate: 81.4 gph (256.8 lph)

Maximum Pressure: 2500 psi (172 bar) for Metallic Pump Heads

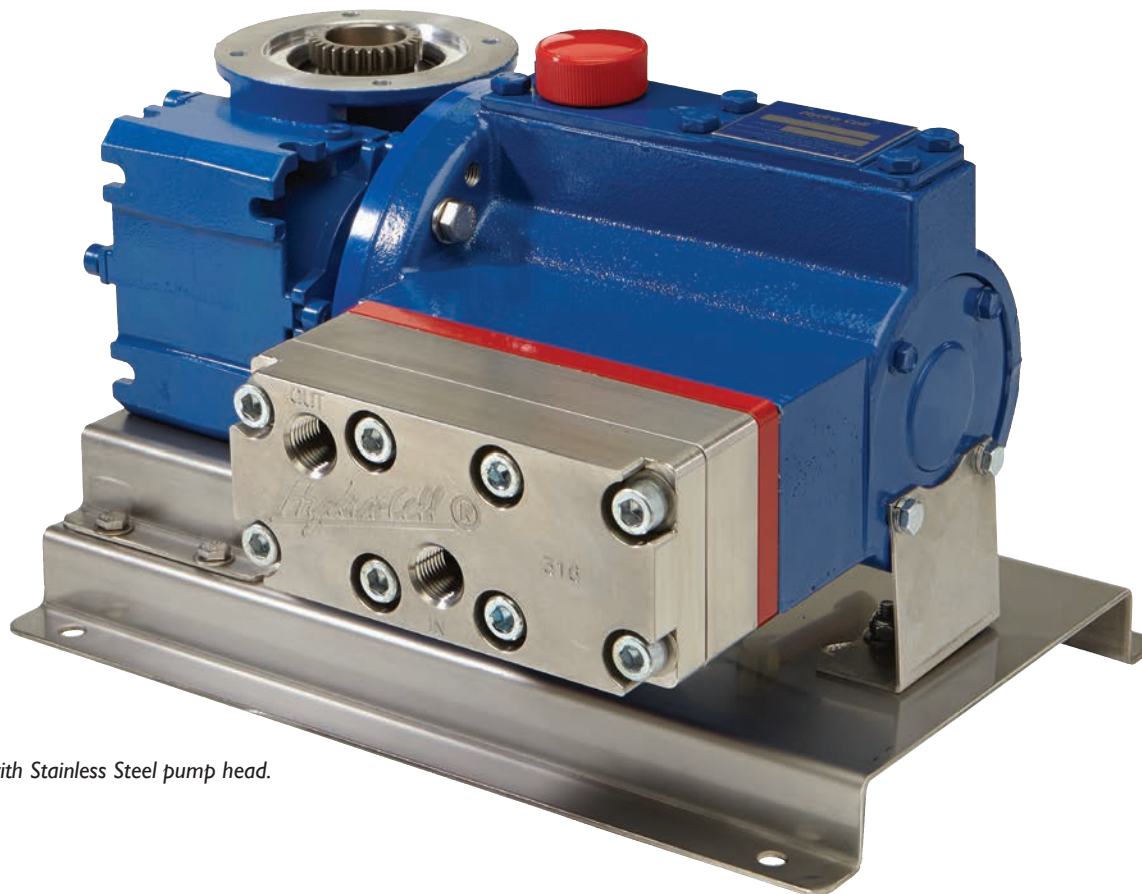

P300 with Stainless Steel pump head.

## Pump Data

Diaphragms per Liquid End	3
Flow Control	Electronic variable speed drive
Maximum Discharge Pressure	
Metallic Heads:	2500 psi (172 bar)
Maximum Inlet Pressure	500 psi (34 bar)
Maximum Operating Temperature	
<i>Consult factory for correct metallic head component selection for temperatures from 160°F (71°C) to 250°F (121°C).</i>	
Metallic Heads:	250°F (121°C)
Maximum Solids Size	500 microns
Inlet Port	1/2 inch NPT or BSPT
Discharge Port	1/2 inch NPT or BSPT
Shaft Rotation	Bi-directional
Oil Capacity	1.1 US quarts (1.05 liters)

Weight (less motor)	
Metallic Heads:	54.5 lbs (24.7 kg)
Dimensions (less motor)	
<i>For NEMA 56 motor frames only; see page 29 for other motor frame sizes.</i>	
Metallic Heads:	15.79" W x 12.25" D x 9.46" H (401.2 mm W x 311.0 mm D x 240.2 mm H)

# P300 Series Performance

## Maximum Flow (gph) at Designated Pressure (psi)

100 psi	Metallic Pump Heads Only (gph)			Pump rpm	Gear Ratio	Motor rpm
	500 psi	1500 psi	2500 psi			
3.221	3.183	3.014	2.741	30	60:1	1800
3.895	3.849	3.655	3.350	36	50:1	
4.939	4.882	4.607	4.272	45	40:1	
6.639	6.548	6.194	5.786	60	30:1	
7.999	7.881	7.463	6.998	72	25:1	
10.04	9.880	9.368	8.815	90	20:1	
13.44	13.21	12.54	11.84	120	15:1	
20.24	19.88	18.89	17.90	180	10:1	
27.03	26.54	25.24	23.96	240	7.5:1	
40.63	39.87	37.93	36.08	360	5:1	
54.23	53.20	50.63	48.19	480	7.5:1	3600
81.42	79.85	76.02		720	5:1	

### Required Motor hp

1/4	1/2	3/4	1	1-1/2	2
-----	-----	-----	---	-------	---

## Maximum Flow (lph) at Designated Pressure (bar)

7 bar	Metallic Pump Heads Only (lph)			Pump rpm	Gear Ratio	Motor rpm
	34 bar	103 bar	172 bar			
10.16	10.04	9.51	8.648	25	60:1	1500
12.29	12.14	11.53	10.57	30	50:1	
15.58	15.40	14.53	13.47	37.5	40:1	
20.94	20.66	19.54	18.25	50	30:1	
25.23	24.86	23.54	22.07	60	25:1	
31.66	31.17	29.55	27.81	75	20:1	
42.39	41.68	39.56	37.36	100	15:1	
63.83	62.70	59.59	56.47	150	10:1	
85.28	83.72	79.61	75.58	200	7.5:1	
128.2	125.8	119.7	113.8	300	5:1	
171.1	167.8	159.7	152.0	400	7.5:1	3000
256.8	251.9	239.8	228.5	600	5:1	

### Required Motor kW

0.18	0.25	0.37	0.55	0.75	1.1	1.5
------	------	------	------	------	-----	-----

# P300 Series Representative Drawings

## Metallic Pump Heads Inches (mm)

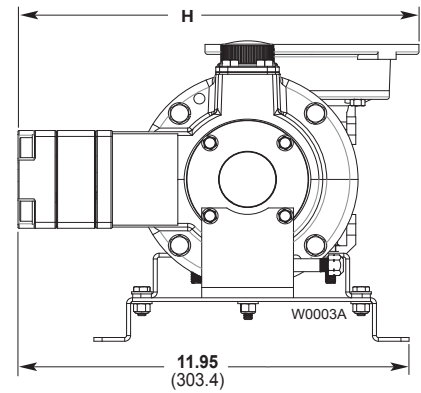
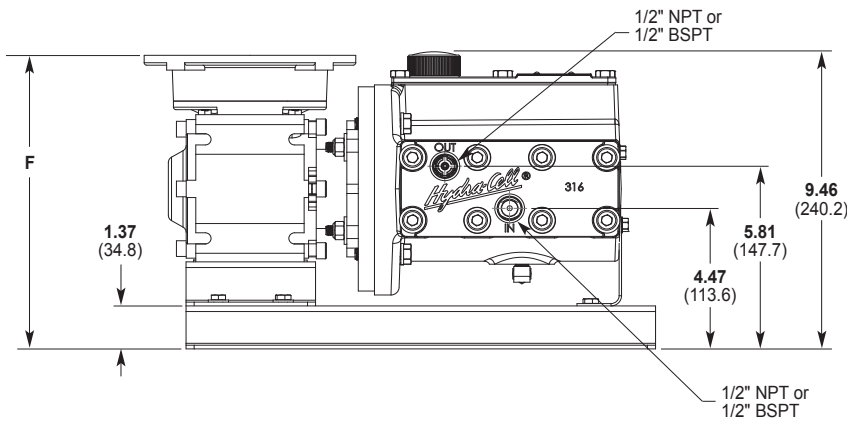
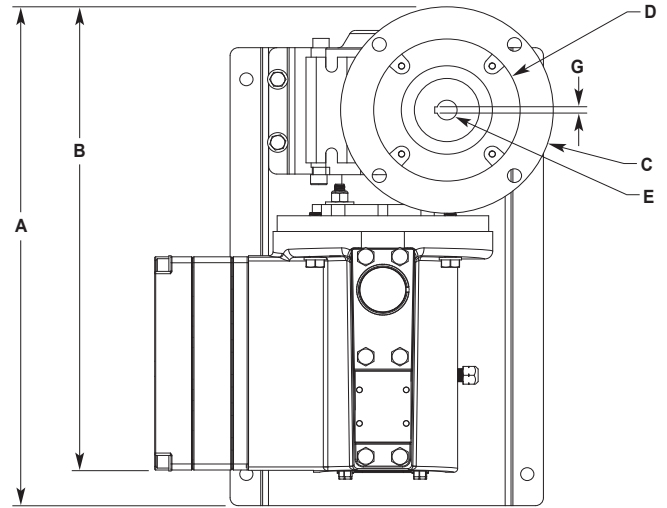
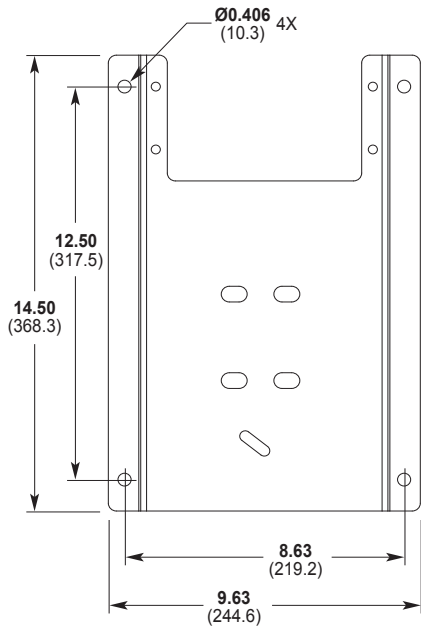

## Dimensions: Inches (mm)

Input Frame Size	A	B	C	D	E	F	G (Square Key)	H
NEMA 56C	15.79 (401.2)	14.70 (373.3)	Ø 6.54 (Ø 166)	Ø 4.50 (Ø 114.3)	Ø 0.62 (Ø 15.7)	9.35 (237.4)	0.187 (4.75)	12.25 (311)
NEMA 143/145TC	15.79 (401.2)	14.70 (373.3)	Ø 6.54 (Ø 166)	Ø 4.50 (Ø 114.3)	Ø 0.87 (Ø 22.2)	9.82 (249.4)	0.187 (4.75)	12.25 (311)
IEC 63 B5	15.28 (388.1)	14.19 (360.4)	Ø 5.51 (Ø 140)	Ø 3.74 (Ø 95)	Ø 0.43 (Ø 11)	9.17 (232.9)	0.157 (4)	11.73 (298.1)
IEC 71 B5	15.67 (398)	14.58 (370.3)	Ø 6.30 (Ø 160)	Ø 4.33 (Ø 110)	Ø 0.55 (Ø 14)	9.17 (232.9)	0.196 (5)	12.13 (308.1)
IEC 80 B5	16.46 (418.1)	15.37 (390.4)	Ø 7.87 (Ø 200)	Ø 5.12 (Ø 130)	Ø 0.75 (Ø 19)	9.17 (232.9)	0.236 (6)	12.91 (327.9)
IEC 90 B5	16.46 (418.1)	15.37 (390.4)	Ø 7.87 (Ø 200)	Ø 5.12 (Ø 130)	Ø 0.94 (Ø 24)	9.69 (246.9)	0.315 (8)	12.91 (327.9)

# P300 Series How to Order

1	2	3	4	5	6	7	8	9	10	11	12	13
P	3	0	0									

A complete pump order number contains 13 digits based on the specified pump materials listed below.

## Pump Configuration (Digits 1-4)

**P300** For all P300 Pumps (Non Kel-Cell)

## Pump Version (Digit 5)

**N** NPT Ports (NEMA motors only)  
**M** BSPT Ports (IEC motors only)  
**X** ATEX BSPT Ports (IEC motors only)

## Pump Head / Retainer Material (Digit 6)

**B** Brass / Hastelloy C  
**R** 304 Stainless Steel / Hastelloy C  
**S** 316L Stainless Steel / Hastelloy C  
**T** Hastelloy C / Hastelloy C

## Diaphragm & O-ring Material / Oil (Digit 7)▲

**E** EPDM (EPDM-compatible oil)  
**X** FKM (Synthetic oil)  
**J** PTFE (Food-contact oil)  
**P** Neoprene (Standard oil)  
**T** Buna-N (Standard oil)

▲ See price list for different actuating oils available with these materials.

## Check Valve Material (Digits 8-9)

### (Valve Spring / Valve Seat / Valve)

**SS** Elgiloy / Nitronic 50 / Nitronic 50  
**TT** Hastelloy C / Hastelloy C / Hastelloy C  
**SD** Elgiloy / Tungsten Carbide / Tungsten Carbide  
**TD** Hastelloy C / Tungsten Carbide / Tungsten Carbide

## Gearbox Ratio (Digits 10-12) NEMA Motors

**060** 60:1 (56C Motor Frame)  
**050** 50:1 (56C Motor Frame)  
**040** 40:1 (56C Motor Frame)  
**030** 30:1 (56C Motor Frame)  
**025** 25:1 (56C Motor Frame)  
**020** 20:1 (56C Motor Frame)  
**015** 15:1 (56C Motor Frame)  
**010** 10:1 (56C Motor Frame)  
**007** 7.5:1 (56C Motor Frame)  
**A07** 7.5:1 (143/145TC Motor Frame)  
**005** 5:1 (56C Motor Frame)  
**A05** 5:1 (143/145TC Motor Frame)

## Gearbox Ratio (Digits 10-12) IEC Motors

**060** 60:1 (63 B5 Motor Frame)  
**050** 50:1 (63 B5 Motor Frame)  
**040** 40:1 (63 B5 Motor Frame)  
**C40** 40:1 (90 B5 Motor Frame)  
**A30** 30:1 (71 B5 Motor Frame)  
**C30** 30:1 (90 B5 Motor Frame)  
**A25** 25:1 (71 B5 Motor Frame)  
**A20** 20:1 (71 B5 Motor Frame)  
**C20** 20:1 (90 B5 Motor Frame)  
**A15** 15:1 (71 B5 Motor Frame)  
**C15** 15:1 (90 B5 Motor Frame)  
**A10** 10:1 (71 B5 Motor Frame)  
**B10** 10:1 (80 B5 Motor Frame)  
**C10** 10:1 (90 B5 Motor Frame)  
**A07** 7.5:1 (71 B5 Motor Frame)  
**B07** 7.5:1 (80 B5 Motor Frame)  
**C07** 7.5:1 (90 B5 Motor Frame)  
**A05** 5:1 (71 B5 Motor Frame)  
**B05** 5:1 (80 B5 Motor Frame)  
**C05** 5:1 (90 B5 Motor Frame)

## Base Plate (Digit 13)

**C** Carbon Steel (Epoxy painted)  
**S** 304 Stainless Steel

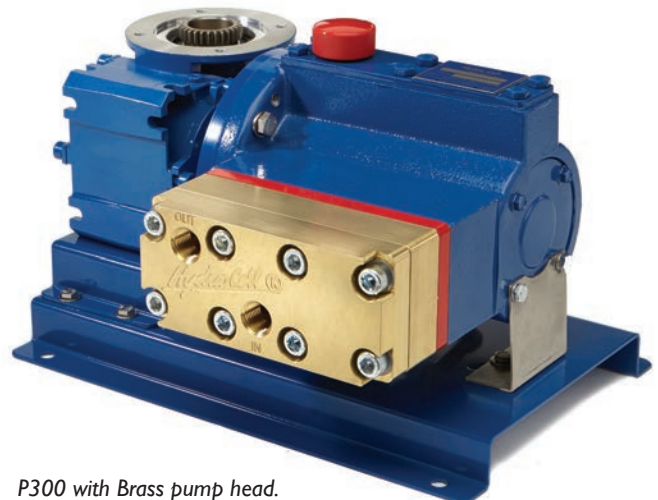

P300 with Brass pump head.

# P400 Series

Maximum Flow Rate: 242.8 gph (765.9 lph)

Maximum Pressure: 1000 psi (69 bar) for Metallic Pump Heads  
350 psi (24 bar) for Non-metallic Pump Heads

## Now Featuring Optimized Valve Plate

Geometric design improvements have reduced the valve pocket by 30% for Hydra-Cell P400 Metering Solutions pumps, providing several advantages:

- Superior performance in gaseous fluid applications.
- Faster, easier priming in low-speed metering applications.
- Improved efficiency because “dead space” in the diaphragm pocket is minimized.
- Decreased chance of pump “pack-out” or vapor lock.
- Increased fluid velocity through the plate (due to the 6% reduction of the port through-holes).

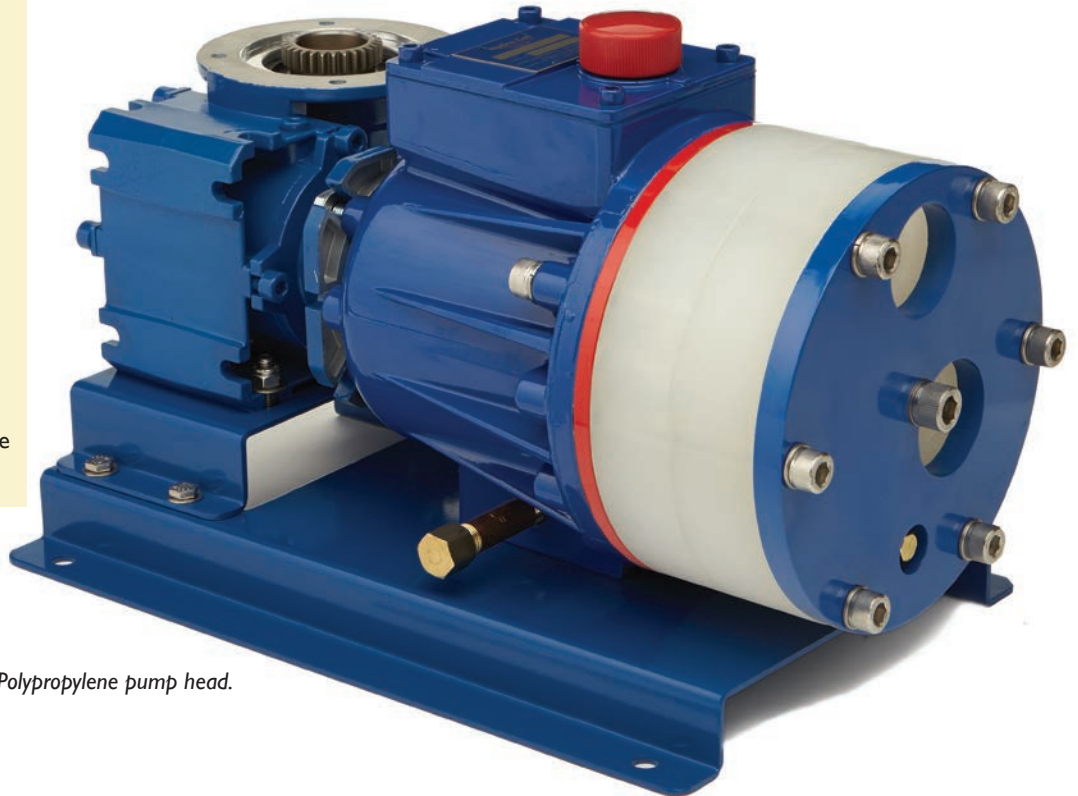

P400 with Polypropylene pump head.

## Pump Data

Diaphragms per Liquid End	3
Flow Control	Electronic variable speed drive
Maximum Discharge Pressure	
Metallic Heads:	1000 psi (69 bar)
Non-metallic Heads:	PVDF- 350 psi (24 bar)
	Polypropylene- 250 psi (17 bar)
Maximum Inlet Pressure	250 psi (17 bar)
Maximum Operating Temperature	
	<i>Consult factory for correct metallic head component selection for temperatures from 160°F (71°C) to 250°F (121°C).</i>
Metallic Heads:	250°F (121°C)
Non-metallic Heads:	140°F (60°C)
Maximum Solids Size	500 microns
Inlet Port	1 inch NPT or BSPT
Discharge Port	3/4 inch NPT or BSPT

Shaft Rotation	Bi-directional
Oil Capacity	1.35 US quarts (1.27 liters)
Weight (less motor)	
Metallic Heads:	65.5 lbs (29.7 kg)
Non-metallic Heads:	52.5 lbs (23.8 kg)
Dimensions (less motor)	
	<i>For NEMA 56 motor frames only; see page 33 for other motor frame sizes.</i>
Metallic Heads:	9.94" W x 16.12" D x 10.29" H (252.4 mm W x 409.4 mm D x 261.3 mm H)
Non-metallic Heads:	9.94" W x 17.29" D x 10.29" H (252.4 mm W x 439.2 mm D x 261.3 mm H)

# P400 Series Performance

## Maximum Flow (gph) at Designated Pressure (psi)

All Pumps (gph)		Metallic Pump Heads Only (gph)		Pump rpm	Gear Ratio	Motor rpm
100 psi	250 psi	500 psi	1000 psi			
9.637	9.280	8.491	6.464	30	60:1	1800
11.652	11.283	10.452	8.269	36	50:1	
14.66	14.30	13.37	11.21	45	40:1	
19.73	19.31	18.30	15.96	60	30:1	
23.79	23.32	22.24	19.75	72	25:1	
29.87	29.34	28.15	25.45	90	20:1	
40.011	39.375	38.00	34.94	120	15:1	
60.290	59.438	57.70	53.92	180	10:1	
80.569	79.501	77.41	72.90	240	7.5:1	
121.1	119.6	116.8	110.9	360	5:1	
161.69	159.75	156.22		480	7.5:1	3600
242.80	240.01			720	5:1	

### Required Motor hp

1/4	1/2	3/4	1	1-1/2	2
-----	-----	-----	---	-------	---

## Maximum Flow (lph) at Designated Pressure (bar)

All Pumps (lph)		Metallic Pump Heads Only (lph)		Pump rpm	Gear Ratio	Motor rpm
7 bar	17 bar	34 bar	69 bar			
30.40	29.27	26.78	20.391	25	60:1	1500
36.76	35.59	32.97	26.09	30	50:1	
46.25	45.10	42.18	35.36	37.5	40:1	
62.24	60.92	57.72	50.33	50	30:1	
75.04	73.58	70.15	62.31	60	25:1	
94.23	92.56	88.80	80.27	75	20:1	
126.21	124.21	119.87	110.21	100	15:1	
190.19	187.50	182.03	170.09	150	10:1	
254.16	250.79	244.18	229.98	200	7.5:1	
382.1	377.4	368.5	349.7	300	5:1	
510.0	503.9	492.8	469.5	400	7.5:1	3000
765.9	757.1	741.4	709.0	600	5:1	

### Required Motor kW

0.18	0.25	0.37	0.55	0.75	1.1	1.5	2.2
------	------	------	------	------	-----	-----	-----

# P400 Series Representative Drawings

## Metallic and Non-metallic Pump Heads Inches (mm)

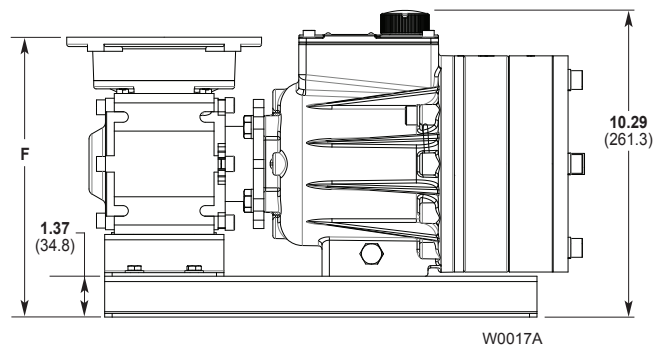
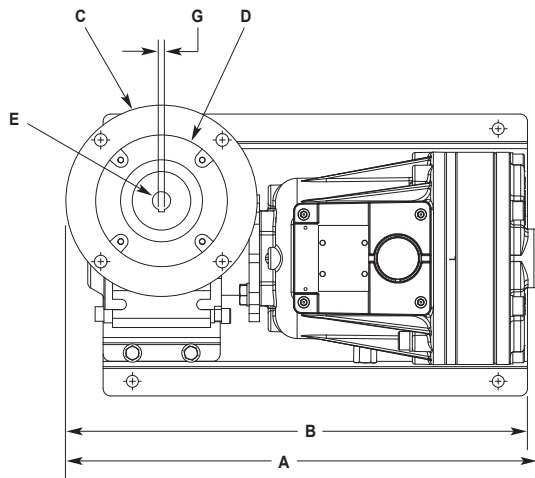
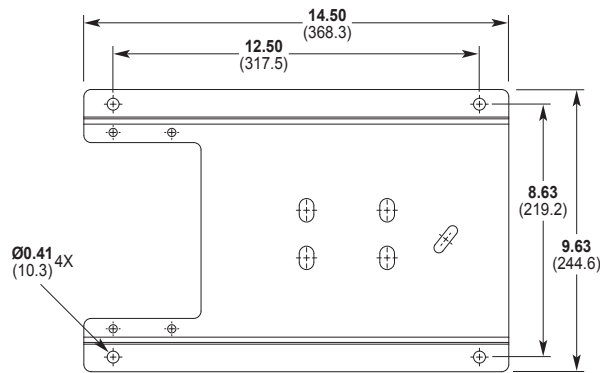
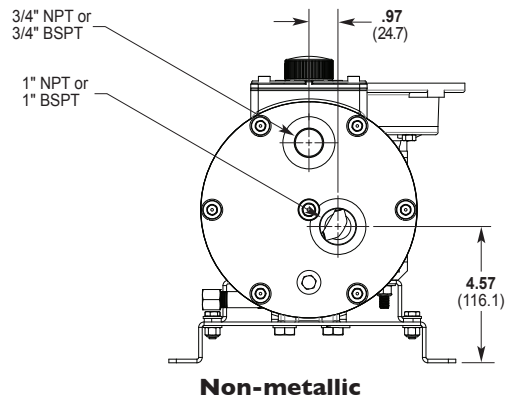
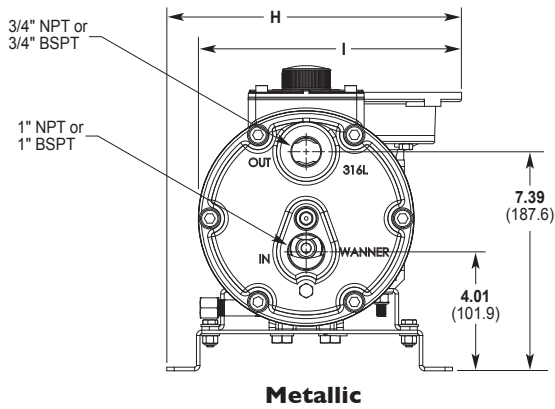

## Dimensions: Inches (mm)

Input Frame Size	A		B	C	D	E	F	G (Square Key)	H	I
	Metallic Pump Head	Plastic Pump Head								
NEMA 56C	16.12 (409.4)	17.29 (439.1)	15.77 (400.6)	Ø 6.54 (Ø 166)	Ø 4.50 (Ø 114.3)	Ø 0.62 (Ø 15.7)	9.39 (238.4)	0.187 (4.75)	9.94 (252.4)	8.86 (225.1)
NEMA 143/145 TC	16.12 (409.4)	17.29 (439.1)	15.77 (400.6)	Ø 6.54 (Ø 166)	Ø 4.50 (Ø 114.3)	Ø 0.87 (Ø 22.2)	9.86 (250.4)	0.187 (4.75)	9.94 (252.4)	8.86 (225.1)
IEC 63 B5	15.60 (396.2)	16.77 (426)	15.25 (387.4)	Ø 5.51 (Ø 140)	Ø 3.74 (Ø 95)	Ø 0.43 (Ø 11)	9.21 (233.9)	0.157 (4)	9.43 (239.5)	8.35 (212.2)
IEC 71 B5	16.00 (406.4)	17.17 (436.1)	15.65 (397.5)	Ø 6.30 (Ø 160)	Ø 4.33 (Ø 110)	Ø 0.55 (Ø 14)	9.21 (233.9)	0.196 (5)	9.82 (249.4)	8.74 (222.1)
IEC 80 B5	16.79 (426.5)	17.96 (456.2)	16.43 (417.32)	Ø 7.87 (Ø 200)	Ø 5.12 (Ø 130)	Ø 0.75 (Ø 19)	9.21 (233.9)	0.236 (6)	10.61 (269.5)	9.53 (242.2)
IEC 90 B5	16.79 (426.5)	17.96 (456.2)	16.43 (417.32)	Ø 7.87 (Ø 200)	Ø 5.12 (Ø 130)	Ø 0.94 (Ø 24)	9.69 (246.9)	0.315 (8)	10.61 (269.5)	9.53 (242.2)

# P400 Series How to Order

1	2	3	4	5	6	7	8	9	10	11	12	13
P	4	0	0									

A complete pump order number contains 13 digits based on the specified pump materials listed below.

## Pump Configuration (Digits 1-4)

**P400** For all P400 Pumps (Kel-Cell) with Optimized Valve Plate

## Pump Version (Digit 5)

**N** NPT Ports or ANSI Flanges (NEMA motors only)  
**M** BSPT Ports or ANSI Flanges (IEC motors only)  
**X** ATEX BSPT Ports (IEC motors only)

## Pump Head / Retainer Material (Digit 6)

**B** Brass / Hastelloy C  
**C** Cast Iron / Hastelloy C  
**M** PVDF / PVDF  
**P** Polypropylene / Polypropylene  
**R** 316L Stainless Steel (ANSI flange class 150 x 600) / Hastelloy C  
**S** 316L Stainless Steel (NPT or BSPT) / Hastelloy C  
**T** Hastelloy CW12MW / Hastelloy C

## Diaphragm & O-ring Material / Oil (Digit 7)<sup>▲</sup>

**A** Atlas / PTFE O-rings (Synthetic oil)  
**E** EPDM (EPDM-compatible oil)  
**X** FKM (Synthetic oil)  
**J** PTFE (Food-contact oil)  
*(Note: PTFE diaphragms require a minimum suction pressure of 15 psi/1 bar.)*  
**P** Neoprene (Standard oil)  
**T** Buna-N (Standard oil)

<sup>▲</sup> See price list for different actuating oils available with these materials.

## Check Valve Material (Digits 8-9)

### (Valve Spring / Valve Seat / Valve)

**SS** Elgiloy / 316L SST / Nitronic 50  
**TT** Hastelloy C / Hastelloy C / Hastelloy C  
**SC** Elgiloy / Ceramic / Ceramic  
**TC** Hastelloy C / Ceramic / Ceramic  
**SD** Elgiloy / Tungsten Carbide / Tungsten Carbide  
**TD** Hastelloy C / Tungsten Carbide / Tungsten Carbide

## Gearbox Ratio (Digits 10-12) NEMA Motors

**060** 60:1 (56C Motor Frame)  
**050** 50:1 (56C Motor Frame)  
**040** 40:1 (56C Motor Frame)  
**030** 30:1 (56C Motor Frame)  
**025** 25:1 (56C Motor Frame)  
**020** 20:1 (56C Motor Frame)  
**015** 15:1 (56C Motor Frame)  
**010** 10:1 (56C Motor Frame)  
**007** 7.5:1 (56C Motor Frame)  
**A07** 7.5:1 (143/145TC Motor Frame)  
**005** 5:1 (56C Motor Frame)  
**A05** 5:1 (143/145TC Motor Frame)

## Gearbox Ratio (Digits 10-12) IEC Motors

**060** 60:1 (63 B5 Motor Frame)  
**050** 50:1 (63 B5 Motor Frame)  
**040** 40:1 (63 B5 Motor Frame)  
**A30** 30:1 (71 B5 Motor Frame)  
**A25** 25:1 (71 B5 Motor Frame)  
**A20** 20:1 (71 B5 Motor Frame)  
**A15** 15:1 (71 B5 Motor Frame)  
**A10** 10:1 (71 B5 Motor Frame)  
**B10** 10:1 (80 B5 Motor Frame)  
**C10** 10:1 (90 B5 Motor Frame)  
**A07** 7.5:1 (71 B5 Motor Frame)  
**B07** 7.5:1 (80 B5 Motor Frame)  
**C07** 7.5:1 (90 B5 Motor Frame)  
**B05** 5:1 (80 B5 Motor Frame)  
**C05** 5:1 (90 B5 Motor Frame)

## Base Plate (Digit 13)

**C** Carbon Steel (Epoxy painted)  
**S** 304 Stainless Steel

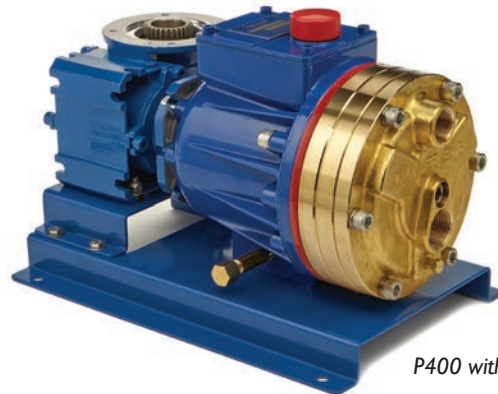

P400 with Brass pump head.

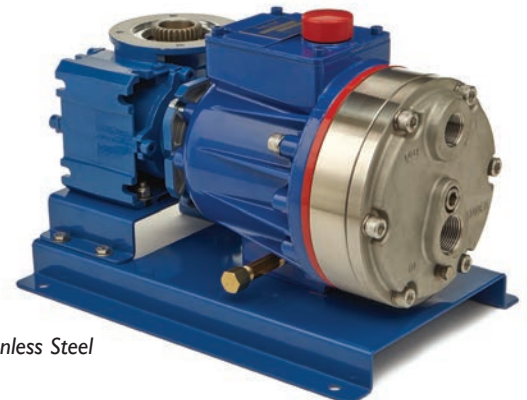

P400 with Stainless Steel pump head.

# P500 Series

Maximum Flow Rate: 425.9 gph (1343.5 lph)

Maximum Pressure: 2500 psi (172 bar) for Metallic Pump Heads

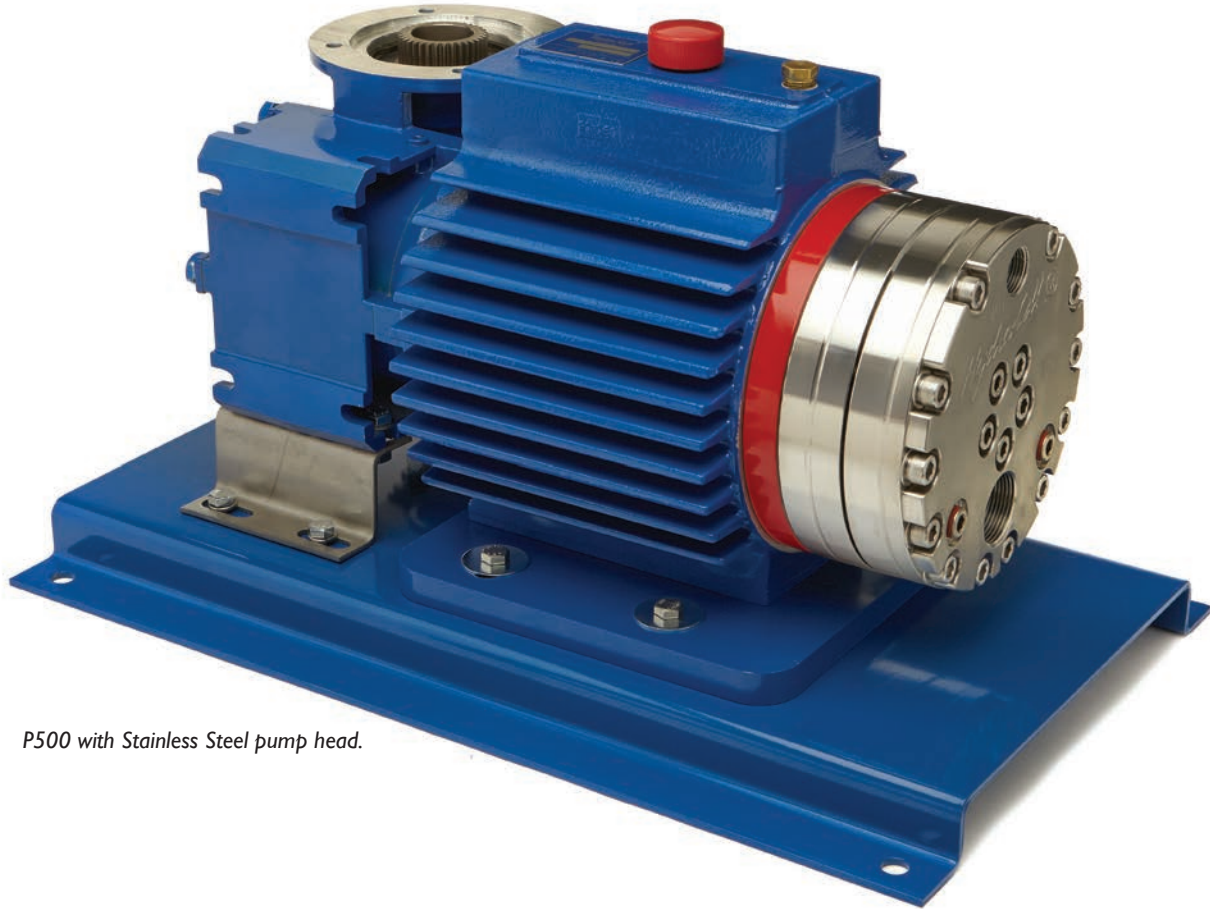

P500 with Stainless Steel pump head.

## Pump Data

Diaphragms per Liquid End	5
Flow Control	Electronic variable speed drive
Maximum Discharge Pressure	
Metallic Heads:	2500 psi (172 bar)
Maximum Inlet Pressure	500 psi (34 bar)
Maximum Operating Temperature	
<i>Consult factory for correct metallic head component selection for temperatures from 160°F (71°C) to 250°F (121°C).</i>	
Metallic Heads:	250°F (121°C)
Maximum Solids Size	800 microns
Inlet Port	1-1/4 inch NPT or BSPT
Discharge Port	3/4 inch NPT or BSPT
Shaft Rotation	Bi-directional
Oil Capacity	2.2 US quarts (2.1 liters)

Weight (less motor)	
Metallic Heads:	192.1 lbs (88.5 kg)
Dimensions (less motor)	
<i>For NEMA 56 motor frames only; see page 37 for other motor frame sizes.</i>	
Metallic Heads:	14.5" W x 24.0" D x 13.9" H (368.3 mm W x 609.6 mm D x 353.1 mm H)

# P500 Series Performance

## Maximum Flow (gph) at Designated Pressure (psi)

100 psi	Metallic Pump Heads Only (gph)			Pump rpm	Gear Ratio	Motor rpm
	500 psi	1500 psi	2500 psi			
17.48	16.96	15.74	14.47	30	60:1	1800
20.97	20.43	19.11	17.71	36	50:1	
26.39	25.73	24.20	22.67	45	40:1	
35.27	34.47	32.63	30.80	60	30:1	
42.37	41.47	39.37	37.31	72	25:1	
53.03	51.97	49.49	47.07	90	20:1	
70.78	69.46	66.35	63.34	120	15:1	
106.3	104.4	100.1	95.88	180	10:1	
141.8	139.4	133.8	128.4	240	7.5:1	
212.8	209.4	201.2	193.5	360	5:1	
283.9	279.4	268.7	258.6	480	7.5:1	3600
425.9	419.3	403.6	388.7	720	5:1	

### Required Motor hp

1/4	1/2	3/4	1	1-1/2	2	3	5	7-1/2	10	15	20
-----	-----	-----	---	-------	---	---	---	-------	----	----	----

## Maximum Flow (lph) at Designated Pressure (bar)

7 bar	Metallic Pump Heads Only (lph)			Pump rpm	Gear Ratio	Motor rpm
	34 bar	103 bar	172 bar			
55.14	53.50	49.66	45.641	25	60:1	1500
66.16	64.44	60.28	55.85	30	50:1	
83.25	81.16	76.32	71.50	37.5	40:1	
111.26	108.75	102.92	97.16	50	30:1	
133.66	130.82	124.19	117.69	60	25:1	
167.27	163.93	156.11	148.49	75	20:1	
223.28	219.11	209.29	199.81	100	15:1	
335.31	329.47	315.67	302.45	150	10:1	
447.33	439.83	422.05	405.10	200	7.5:1	
671.4	660.6	634.8	610.4	300	5:1	
895.4	881.3	847.6	815.7	400	7.5:1	3000
1343.5	1322.7	1273.1	1226.3	600	5:1	

### Required Motor kW

0.37	0.55	0.75	1.1	1.5	2.2
3	3.7	4	5.5	7.5	11

# P500 Series Representative Drawings

## Metallic Pump Heads Inches (mm)

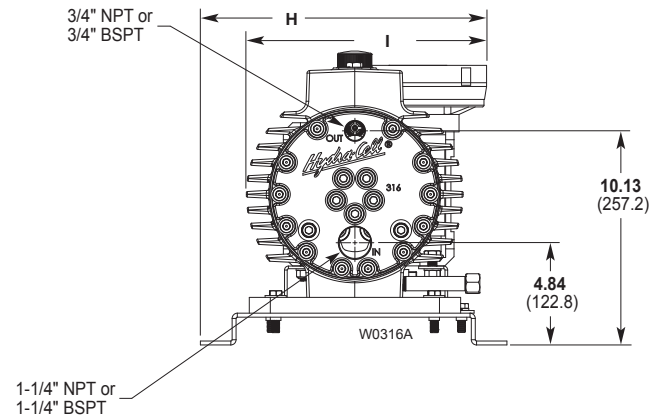
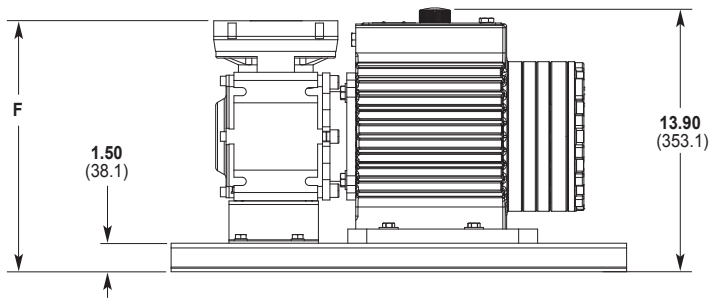
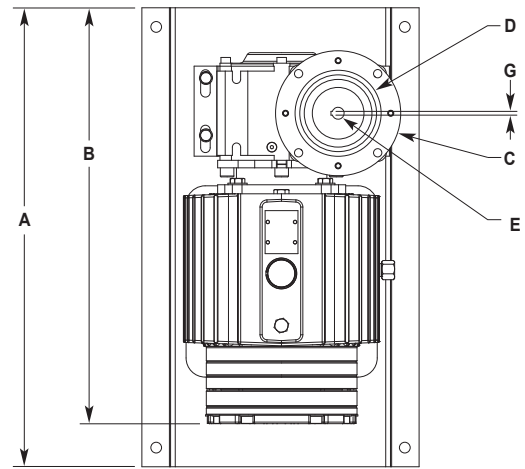
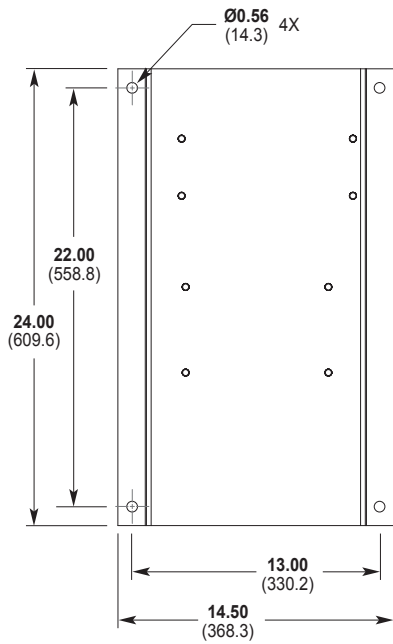

For representative drawings P500 C and D reducers (NEMA motor sizes 213/215TC and 254/256TC), please visit [www.Hydra-Cell.com](http://www.Hydra-Cell.com).

## Dimensions: Inches (mm)

Input Frame Size	A	B	C	D	E	F	G (Square Key)	H	I
NEMA 56C	21.76 (552.6)	19.05 (495.3)	Ø 6.54 (Ø 166)	Ø 4.50 (Ø 114.3)	Ø 0.62 (Ø 15.7)	13.22 (335.9)	0.187 (4.75)	13.53 (343.7)	11.36 (288.5)
NEMA 143/145 TC	21.76 (552.6)	19.05 (495.3)	Ø 6.54 (Ø 166)	Ø 4.50 (Ø 114.3)	Ø 0.87 (Ø 22.2)	13.22 (335.9)	0.187 (4.75)	13.53 (343.7)	11.36 (288.5)
NEMA 182/183 TC	26.07 (585)	20.36 (517.1)	Ø 9.17 (Ø 233)	Ø 8.50 (Ø 218.9)	Ø 1.12 (Ø 26.6)	13.77 (349.75)	0.25 (6.35)	14.84 (376.9)	12.68 (322)
IEC 71 B5	21.64 (549.7)	18.93 (480.8)	Ø 6.54 (Ø 166)	Ø 4.33 (Ø 110)	Ø 0.55 (Ø 14)	13.42 (340.7)	0.196 (5)	13.41 (340.6)	11.24 (285.4)
IEC 80 B5	22.42 (569.6)	19.71 (500.6)	Ø 7.87 (Ø 200)	Ø 5.12 (Ø 130)	Ø 0.75 (Ø 19)	13.42 (340.7)	0.236 (6)	14.20 (360.6)	12.02 (305.3)
IEC 90 B5	22.42 (569.6)	19.71 (500.6)	Ø 7.87 (Ø 200)	Ø 5.12 (Ø 130)	Ø 0.94 (Ø 24)	13.42 (340.7)	0.314 (8)	14.20 (360.6)	12.02 (305.3)
IEC 100/112 B14	21.64 (549.7)	18.93 (480.8)	Ø 6.30 (Ø 160)	Ø 4.33 (Ø 110)	Ø 1.10 (Ø 28)	13.42 (340.7)	0.314 (8)	13.41 (340.6)	11.24 (285.4)

# P500 Series How to Order

1	2	3	4	5	6	7	8	9	10	11	12	13
P	5	0	0									

A complete pump order number contains 13 digits based on the specified pump materials listed below.

## Pump Configuration (Digits 1-4)

**P500** For all P500 Pumps (Non Kel-Cell)

## Pump Version (Digit 5)

**N** NPT Ports (NEMA motors only)  
**M** BSPT Ports (IEC motors only)  
**X** ATEX BSPT Ports (IEC motors only)

## Pump Head / Retainer Material (Digit 6)

**B** Brass / Hastelloy C  
**S** 316L Stainless Steel / Hastelloy C  
**T** Hastelloy C / Hastelloy C

## Diaphragm & O-ring Material / Oil (Digit 7)<sup>▲</sup>

**A** Aflas / PTFE O-rings (Synthetic oil)  
**X** FKM (Synthetic oil)  
**T** Buna-N (Standard oil)

<sup>▲</sup> See price list for different actuating oils available with these materials.

## Check Valve Material (Digits 8-9)

### (Valve Spring / Valve Seat / Valve)

**SS** Elgiloy / Nitronic 50 / Nitronic 50  
**TT** Hastelloy C / Hastelloy C / Hastelloy C  
**SD** Elgiloy / Tungsten Carbide / Tungsten Carbide  
**TD** Hastelloy C / Tungsten Carbide / Tungsten Carbide

## Gearbox Ratio (Digits 10-12) NEMA Motors

<b>060</b>	60:1	(56C Motor Frame)
<b>050</b>	50:1	(56C Motor Frame)
<b>040</b>	40:1	(56C Motor Frame)
<b>A40</b>	40:1	(143/145TC Motor Frame)
<b>030</b>	30:1	(56C Motor Frame)
<b>A30</b>	30:1	(143/145TC Motor Frame)
<b>025</b>	25:1	(56C Motor Frame)
<b>A25</b>	25:1	(143/145TC Motor Frame)
<b>020</b>	20:1	(56C Motor Frame)
<b>A20</b>	20:1	(143/145TC Motor Frame)
<b>015</b>	15:1	(56C Motor Frame)
<b>A15</b>	15:1	(143/145TC Motor Frame)
<b>B15</b>	15:1	(182/184TC Motor Frame)
<b>010</b>	10:1	(56C Motor Frame)
<b>A10</b>	10:1	(143/145TC Motor Frame)
<b>B10</b>	10:1	(182/184TC Motor Frame)
<b>007</b>	7.5:1	(56C Motor Frame)
<b>A07</b>	7.5:1	(143/145TC Motor Frame)
<b>B07</b>	7.5:1	(182/184TC Motor Frame)
<b>C07</b>	7.5:1	(213/215TC Motor Frame)
<b>D07</b>	7.5:1	(254/256TC Motor Frame)
<b>005</b>	5:1	(56C Motor Frame)
<b>A05</b>	5:1	(143/145TC Motor Frame)
<b>B05</b>	5:1	(182/184TC Motor Frame)
<b>C05</b>	5:1	(213/215TC Motor Frame)
<b>D05</b>	5:1	(254/256TC Motor Frame)

## Base Plate (Digit 13) NEMA Motors

**H** Carbon Steel (Epoxy painted) for O, A & B reducers, size 75  
**G** Carbon Steel (Epoxy painted) for C & D reducers

## Gearbox Ratio (Digits 10-12) IEC Motors

<b>A60</b>	60:1	(71 B5 Motor Frame)
<b>B60</b>	60:1	(80 B5 Motor Frame)
<b>A50</b>	50:1	(71 B5 Motor Frame)
<b>B50</b>	50:1	(80 B5 Motor Frame)
<b>A40</b>	40:1	(71 B5 Motor Frame)
<b>B40</b>	40:1	(80 B5 Motor Frame)
<b>A30</b>	30:1	(71 B5 Motor Frame)
<b>B30</b>	30:1	(80 B5 Motor Frame)
<b>B25</b>	25:1	(80 B5 Motor Frame)
<b>C25</b>	25:1	(90 B5 Motor Frame)
<b>B20</b>	20:1	(80 B5 Motor Frame)
<b>C20</b>	20:1	(90 B5 Motor Frame)
<b>B15</b>	15:1	(80 B5 Motor Frame)
<b>C15</b>	15:1	(90 B5 Motor Frame)
<b>B10</b>	10:1	(80 B5 Motor Frame)
<b>C10</b>	10:1	(90 B5 Motor Frame)
<b>D10</b>	10:1	(100/112 B14 Motor Frame)
<b>B07</b>	7.5:1	(80 B5 Motor Frame)
<b>C07</b>	7.5:1	(90 B5 Motor Frame)
<b>D07</b>	7.5:1	(100/112 B14 Motor Frame)
<b>B05</b>	5:1	(80 B5 Motor Frame)
<b>C05</b>	5:1	(90 B5 Motor Frame)
<b>D05</b>	5:1	(100/112 B14 Motor Frame)

## Base Plate (Digit 13) IEC Motors

**H** Carbon Steel (Epoxy painted) size 75

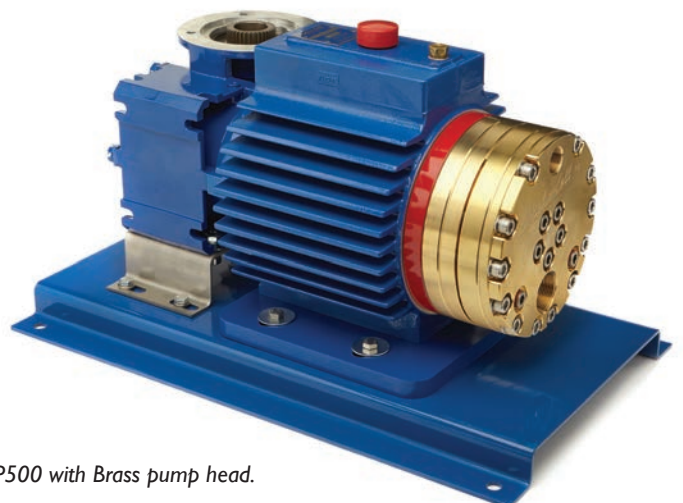

P500 with Brass pump head.

# P600 Series

Maximum Flow Rate: 890.3 gph (2808.0 lph)  
 Maximum Pressure: 1000 psi (69 bar) for Metallic Pump Heads  
 350 psi (24 bar) for Non-metallic Pump Heads

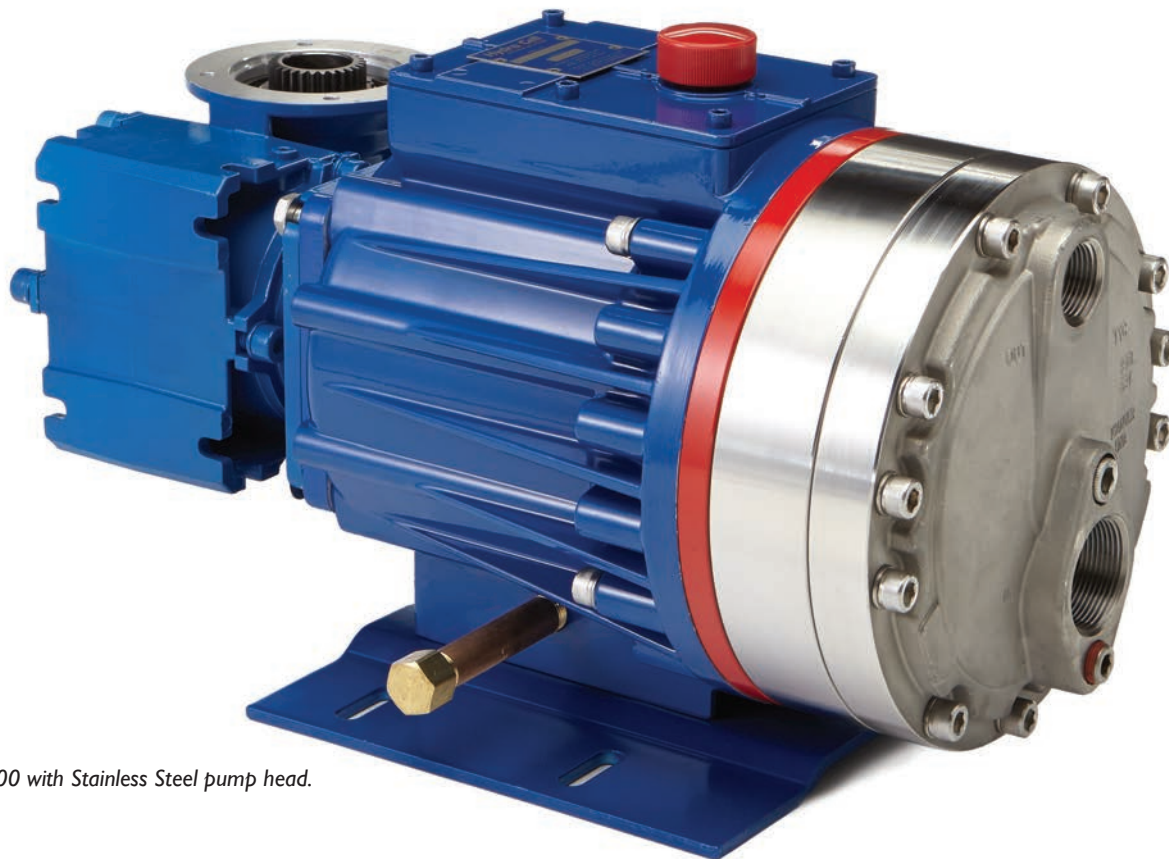

P600 with Stainless Steel pump head.

## Pump Data

Diaphragms per Liquid End	3
Flow Control	Electronic variable speed drive
Maximum Discharge Pressure	
Metallic Heads:	1000 psi (69 bar)
Non-metallic Heads:	PVDF- 350 psi (24 bar) Polypropylene- 250 psi (17 bar)
Maximum Inlet Pressure	250 psi (17 bar)
Maximum Operating Temperature	
	<i>Consult factory for correct metallic head component selection for temperatures from 160 °F (71 °C) to 250 °F (121 °C).</i>
Metallic Heads:	250 °F (121 °C)
Non-metallic Heads:	140 °F (60 °C)
Maximum Solids Size	500 microns
Inlet Port	1-1/2 inch NPT or BSPT
Discharge Port	1 inch NPT or BSPT

Shaft Rotation	Bi-directional
Oil Capacity	2.5 US quarts (2.4 liters)
Weight (less motor)	
Metallic Heads:	146.0 lbs (66.2 kg)
Non-metallic Heads:	111.0 lbs (50.3 kg)
Dimensions (less motor)	
	<i>For NEMA 56 motor frames only; see page 41 for other motor frame sizes.</i>
Metallic Heads:	10.74" W x 20.64" D x 11.57" H (272.7 mm W x 524.3 mm D x 293.9 mm H)
Non-metallic Heads:	10.74" W x 21.56" D x 11.57" H (272.7 mm W x 547.6 mm D x 293.9 mm H)

# P600 Series Performance

## Maximum Flow (gph) at Designated Pressure (psi)

All Pumps (gph)		Metallic Pump Heads Only (gph)		Pump rpm	Gear Ratio	Motor rpm
100 psi	250 psi	500 psi	1000 psi			
36.49	36.12	35.21	33.25	30	60:1	1800
43.90	43.48	42.49	40.35	36	50:1	
55.00	54.53	53.39	51.17	45	40:1	
73.56	72.97	71.58	68.75	60	30:1	
88.41	87.71	86.12	82.81	72	25:1	
110.7	109.8	107.9	103.9	90	20:1	
147.8	146.7	144.3	139.1	120	15:1	
222.1	220.4	217.0	209.4	180	10:1	
296.3	294.1	289.8	279.7	240	7.5:1	
444.8	441.6	435.2	420.3	360	5:1	
593.3	589.0	580.7	560.9	480	7.5:1	3600
890.3	883.9	871.6	842.1	720	5:1	

### Required Motor hp

1/2	3/4	1	1-1/2	2	3	5	7-1/2	10	15
-----	-----	---	-------	---	---	---	-------	----	----

## Maximum Flow (lph) at Designated Pressure (bar)

All Pumps (lph)		Metallic Pump Heads Only (lph)		Pump rpm	Gear Ratio	Motor rpm
7 bar	17 bar	34 bar	69 bar			
115.1	113.9	111.1	104.9	25	60:1	1500
138.5	137.2	134.0	127.3	30	50:1	
173.5	172.0	168.4	161.4	37.5	40:1	
232.0	230.2	225.8	216.9	50	30:1	
278.9	276.7	271.7	261.2	60	25:1	
349.2	346.5	340.5	327.8	75	20:1	
466.3	462.7	455.2	438.6	100	15:1	
700.5	695.3	684.7	660.4	150	10:1	
934.7	927.9	914.1	882.2	200	7.5:1	
1403	1393	1373	1326	300	5:1	
1872	1858	1832	1769	400	7.5:1	3000
2808	2788	2750	2656	600	5:1	

### Required Motor kW

0.37	0.55	0.75	1.1	1.5	2.2
3	3.7	4	5.5	7.5	

Capacity data is shown for pumps with elastomeric diaphragms. Consult factory for performance characteristics of pumps with PTFE diaphragms.

# P600 Series Representative Drawings

## Metallic and Non-metallic Pump Heads Inches (mm)

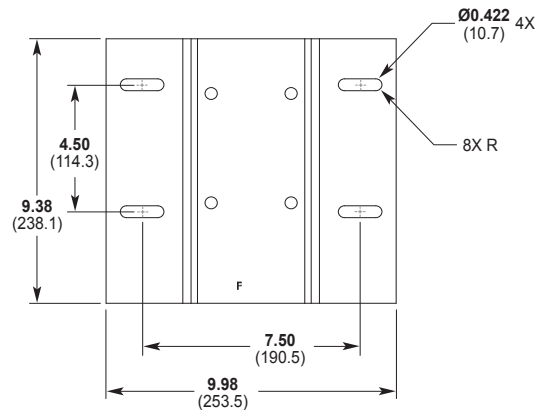
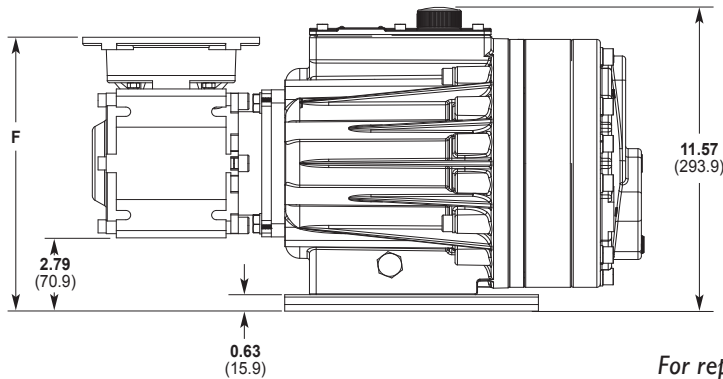
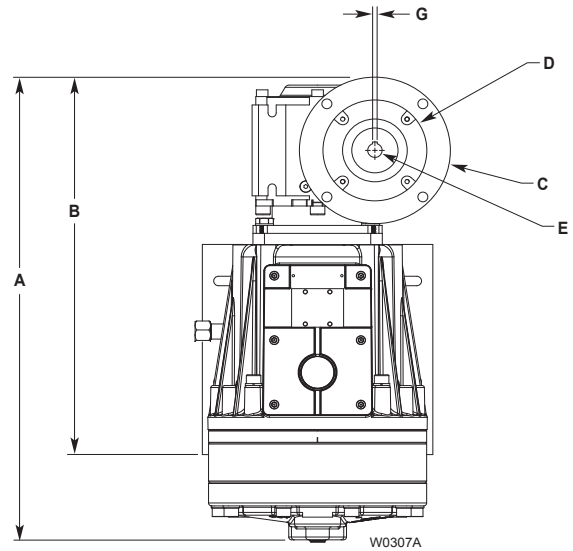
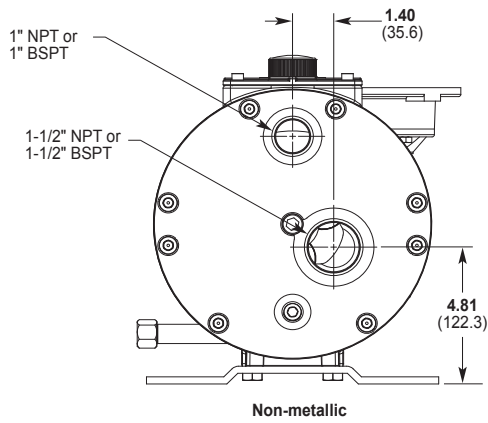
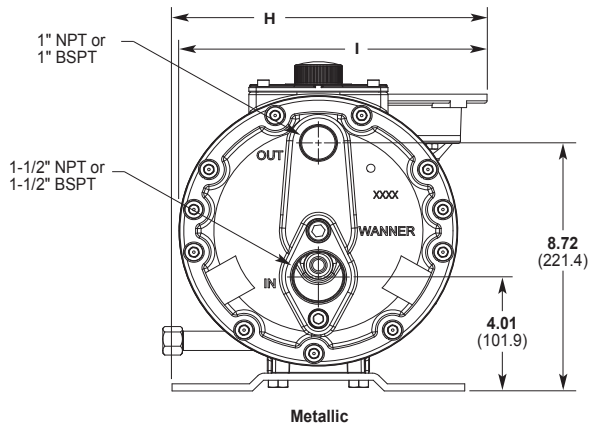

For representative drawings P600 C and D reducers (NEMA motor sizes 213/215TC and 254/256TC), please visit [www.Hydra-Cell.com](http://www.Hydra-Cell.com).

## Dimensions: Inches (mm)

Input Frame Size	A		B	C	D	E	F	G (Square Key)	H	I
	Metallic Pump Head	Plastic Pump Head								
NEMA 56C	20.64 (524.3)	21.56 (547.6)	16.84 (427.7)	Ø 6.54 (Ø 166)	Ø 4.50 (Ø 114.3)	Ø 0.62 (Ø 15.7)	10.43 (264.9)	0.187 (4.75)	10.74 (272.7)	10.49 (266.4)
NEMA 143/145 TC	20.64 (524.3)	21.56 (547.6)	16.84 (427.7)	Ø 6.54 (Ø 166)	Ø 4.50 (Ø 114.3)	Ø 0.87 (Ø 22.2)	10.90 (276.9)	0.187 (4.75)	10.74 (272.7)	10.49 (266.4)
NEMA 182/184 TC	21.95 (557.5)	22.88 (581.2)	18.16 (461.3)	Ø 9.17 (Ø 233)	Ø 8.50 (Ø 215.9)	Ø 1.12 (Ø 28.4)	12.03 (305.6)	0.25 (6.35)	12.06 (306.3)	11.81 (300)
IEC 63 B5	20.13 (511.3)	21.04 (534.4)	16.33 (414.8)	Ø 5.51 (Ø 140)	Ø 3.74 (Ø 95)	Ø 0.43 (Ø 11)	10.25 (260.4)	0.157 (4)	10.22 (259.6)	9.97 (253.3)
IEC 71 B5	20.52 (521.2)	21.44 (544.6)	16.72 (424.7)	Ø 6.30 (Ø 160)	Ø 4.33 (Ø 110)	Ø 0.55 (Ø 14)	10.25 (260.4)	0.196 (5)	10.62 (269.7)	10.37 (263.4)
IEC 80 B5	21.30 (541)	22.23 (564.7)	17.5 (444.5)	Ø 7.87 (Ø 200)	Ø 5.12 (Ø 130)	Ø 0.75 (Ø 19)	10.25 (260.4)	0.236 (6)	11.40 (289.6)	11.15 (283.3)
IEC 90 B5	21.30 (541)	22.23 (564.7)	17.5 (444.5)	Ø 7.87 (Ø 200)	Ø 5.12 (Ø 130)	Ø 0.94 (Ø 24)	10.25 (260.4)	0.314 (8)	11.40 (289.6)	11.15 (283.3)

# P600 Series How to Order

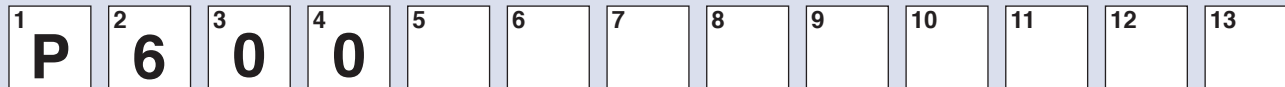

A complete pump order number contains 13 digits based on the specified pump materials listed below.

## Pump Configuration (Digits 1-4)

**P600** For all P600 Pumps (Kel-Cell)

## Pump Version (Digit 5)

**N** NPT Ports or ANSI Flanges (NEMA motors only)  
**M** BSPT Ports or ANSI Flanges (IEC motors only)  
**X** ATEX BSPT Ports (IEC motors only)

## Pump Head / Retainer Material (Digit 6)

**B** Brass / Hastelloy C  
**C** Cast Iron / Hastelloy C  
**M** PVDF / PVDF  
**P** Polypropylene / Polypropylene  
**R** 316L Stainless Steel (ANSI flange class 150 x 600) / Hastelloy C  
**S** 316L Stainless Steel (NPT or BSPT) / Hastelloy C  
**T** Hastelloy CW12MW / Hastelloy C

## Diaphragm & O-ring Material / Oil (Digit 7)<sup>▲</sup>

**A** Atlas / PTFE O-rings (Synthetic oil)  
**E** EPDM (EPDM-compatible oil)  
**X** FKM (Synthetic oil)  
**J** PTFE (Food-contact oil)  
*(Note: PTFE diaphragms require a minimum suction pressure of 15 psi/1 bar.)*  
**P** Neoprene (Standard oil)  
**T** Buna-N (Standard oil)

<sup>▲</sup> See price list for different actuating oils available with these materials.

## Check Valve Material (Digits 8-9)

### (Valve Spring / Valve Seat / Valve)

**SS** Elgiloy / Nitronic 50 / Nitronic 50  
**TT** Hastelloy C / Hastelloy C / Hastelloy C  
**SC** Elgiloy / Ceramic / Ceramic  
**TC** Hastelloy C / Ceramic / Ceramic  
**SD** Elgiloy / Tungsten Carbide / Tungsten Carbide  
**TD** Hastelloy C / Tungsten Carbide / Tungsten Carbide

## Gearbox Ratio (Digits 10-12) NEMA Motors

**060** 60:1 (56C Motor Frame)  
**050** 50:1 (56C Motor Frame)  
**040** 40:1 (56C Motor Frame)  
**A40** 40:1 (143/145TC Motor Frame)  
**030** 30:1 (56C Motor Frame)  
**A30** 30:1 (143/145TC Motor Frame)  
**025** 25:1 (56C Motor Frame)  
**A25** 25:1 (143/145TC Motor Frame)  
**020** 20:1 (56C Motor Frame)  
**A20** 20:1 (143/145TC Motor Frame)  
**015** 15:1 (56C Motor Frame)  
**A15** 15:1 (143/145TC Motor Frame)  
**010** 10:1 (56C Motor Frame)  
**A10** 10:1 (143/145TC Motor Frame)  
**B10** 10:1 (182/184TC Motor Frame)  
**007** 7.5:1 (56C Motor Frame)  
**A07** 7.5:1 (143/145TC Motor Frame)

**B07** 7.5:1 (182/184TC Motor Frame)  
**C07** 7.5:1 (213/215TC Motor Frame)  
**D07** 7.5:1 (254/256TC Motor Frame)  
**005** 5:1 (56C Motor Frame)  
**A05** 5:1 (143/145TC Motor Frame)  
**B05** 5:1 (182/184TC Motor Frame)  
**C05** 5:1 (213/215TC Motor Frame)  
**D05** 5:1 (254/256TC Motor Frame)

## Base Plate (Digit 13) NEMA Motors

**C** Carbon Steel (Epoxy painted) for 0 reducers, size 63  
**H** Carbon Steel (Epoxy painted) for A & B reducers, size 75  
**G** Carbon Steel (Epoxy painted) for C & D reducers

## Gearbox Ratio (Digits 10-12) IEC Motors

**A60** 60:1 (71 B5 Motor Frame)  
**B60** 60:1 (80 B5 Motor Frame)  
**A50** 50:1 (71 B5 Motor Frame)  
**B50** 50:1 (80 B5 Motor Frame)  
**A40** 40:1 (71 B5 Motor Frame)  
**B40** 40:1 (80 B5 Motor Frame)  
**A30** 30:1 (71 B5 Motor Frame)  
**B30** 30:1 (80 B5 Motor Frame)  
**B25** 25:1 (80 B5 Motor Frame)  
**C25** 25:1 (90 B5 Motor Frame)  
**B20** 20:1 (80 B5 Motor Frame)  
**C20** 20:1 (90 B5 Motor Frame)  
**B15** 15:1 (80 B5 Motor Frame)  
**C15** 15:1 (90 B5 Motor Frame)  
**B10** 10:1 (80 B5 Motor Frame)  
**C10** 10:1 (90 B5 Motor Frame)  
**D10** 10:1 (100/112 B14 Motor Frame)  
**B07** 7.5:1 (80 B5 Motor Frame)  
**C07** 7.5:1 (90 B5 Motor Frame)  
**D07** 7.5:1 (100/112 B14 Motor Frame)  
**B05** 5:1 (80 B5 Motor Frame)  
**C05** 5:1 (90 B5 Motor Frame)  
**D05** 5:1 (100/112 B14 Motor Frame)

## Base Plate (Digit 13) IEC Motors

**H** Carbon Steel (Epoxy painted) for A & B reducers, size 75  
**G** Carbon Steel (Epoxy painted) for C & D reducers

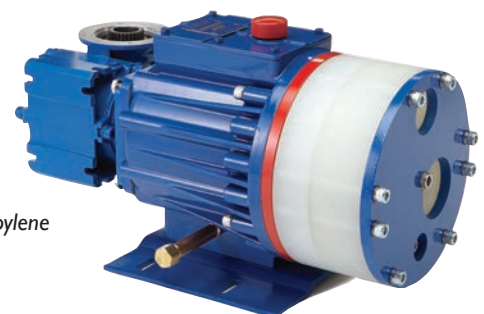

P600 with Polypropylene pump head.

# Hydra-Cell® MT8 Triplex Metering Pump

**Hydra-Cell®**  
METERING SOLUTIONS™

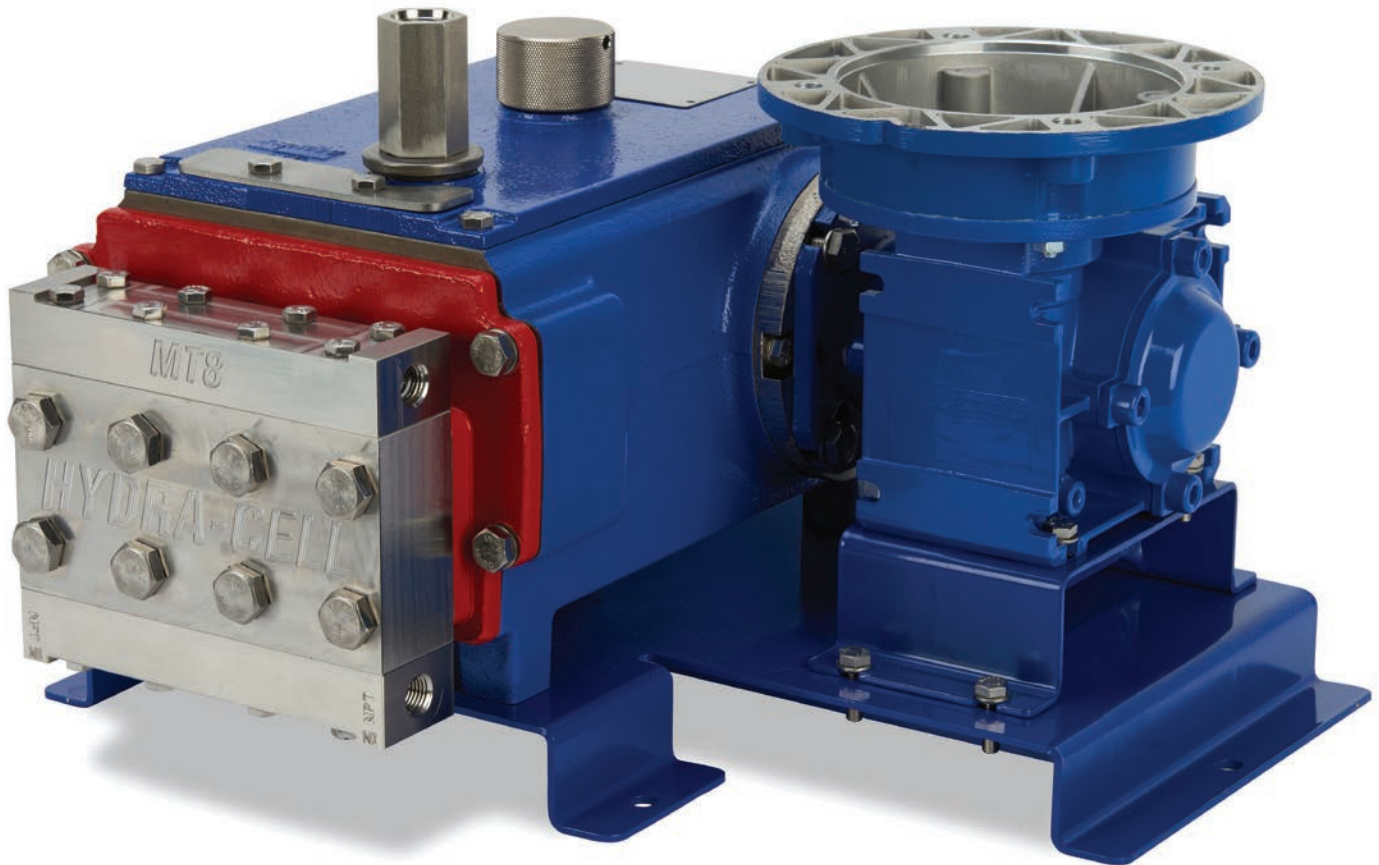

## MT8

Hydra-Cell Metering Solutions pumps exceed API 675 performance standards for Steady-State Accuracy ( $\pm 1\%$ ), Linearity ( $\pm 3\%$ ), and Repeatability ( $\pm 3\%$ ).

### Designed for Low Flow Rates with Linear, Virtually Pulse-free Flow

- Multiple-diaphragm design provides linear, virtually pulse-free flow without the need for expensive pulsation dampeners.
- Designed for low flow rates at high or low-to-medium pressures.
- Can run dry indefinitely without damage to the pump in the event of a blocked suction line or other conditions.
- Features simple-to-replace cartridge check valves with double-sealing surfaces.
- Electronic flow control increases accuracy and reliability.
- Available with manual flow adjustment that can be used in hazardous areas or for local flow control.
- The integral relief valve protects the pump from over pressurization on the discharge side.
- Handles a variety of processing fluids.
- One pump covers a wide range of flows and pressures - reducing inventory requirements with fast, simple field conversion.
- Suction and discharge ports are positioned on both sides of the liquid end for installation versatility.
- Duplexing option doubles capacity and equipment savings.
- Hydraulically-actuated, balanced diaphragms provide superior performance across the entire pressure range.
- Seal-less design means no seals, cups, or packing to leak or replace.
- The patented overfill/underfill valve system ensures optimum actuating oil on every stroke for continuous accuracy and protects the pump and diaphragms.
- Rugged construction with sealing oil cap.
- Smaller footprint saves valuable space.

# Hydra-Cell® MT8 Applications and Configurations

Designed for low flow rates at maximum discharge pressures of 350 psi (24 bar) to 3500 psi (241 bar) depending on pump head material, the MT8 is ideal for many general-industrial as well as specialized processing applications.

- Chemical Metering & Injection
- Food & Beverage Processing
- High-pressure Chemical Reaction
- High-pressure Process Chromatography
- Oil & Gas (offshore and onshore)
- Personal Care Product Manufacturing
- Pharmaceutical Manufacturing
- Plastics Processing
- Polyurethane Foam Production
- Power Plant/Boiler Feed
- Water & Wastewater Treatment

## MT8 with Manual Variable Speed Gearbox

The MT8 is optionally available with a manual adjustment controller to provide local control of the flow rate at the pump. It can be used in hazardous-duty locations and to expand the turndown ratio within the performance envelope of the pump.

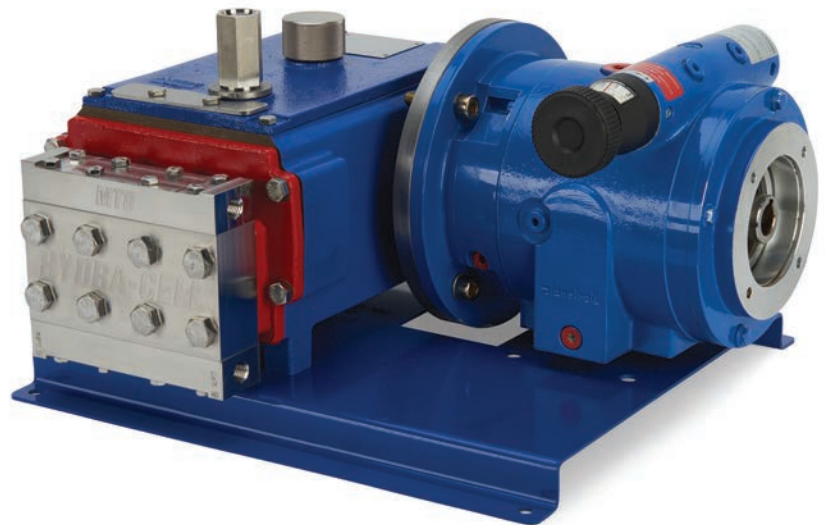

## MT8 Duplexing Option

Two MT8 pumps can be run with only one gearbox and one motor. This “duplexing” option doubles capacity with a smaller footprint and lower investment cost than conventional metering pumps.

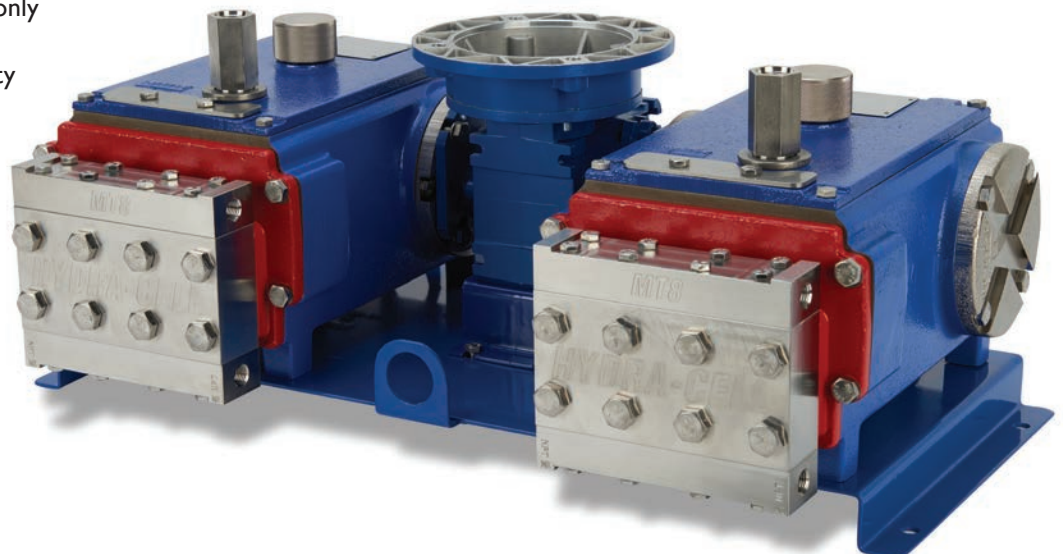

# MT8 Pump Performance

## Performance

Maximum Flow at Designated Pressure for Pumps with Electronic Gearbox Reducers

All Pumps in Gallons per Hour (gph)					Pump rpm	Gear Ratio	Motor rpm
350 psi	500 psi	1500 psi	2500 psi	3500 psi			
0.479	0.473	0.429	0.387	0.349	18	100:1	1800
0.593	0.587	0.532	0.479	0.428	22.5	80:1	
0.784	0.776	0.703	0.635	0.567	30	60:1	
0.972	0.961	0.872	0.795	0.714	36	50:1	
1.189	1.177	1.089	0.985	0.888	45	40:1	
1.609	1.593	1.437	1.309	1.176	60	30:1	
2.336	2.312	2.105	1.924	1.727	90	20:1	
4.706	4.657	4.257	3.839	3.430	180	10:1	
6.218	6.156	5.556	5.064	4.464	240	7.5:1	
8.000*	8.000*	8.000*	7.320*	6.530*	360	5:1	

### Required Motor hp

1/2

\* Flow rates above 8 gph are not guaranteed to meet API 675 Performance Standards; therefore, pump rpm should be limited to 315 at 350 psi and 352 at 1500 psi when using a 5:1 gear reducer and 1800 rpm motor. To reach 8 gph at pressures above 1700 psi with the same reducer and motor, the VFD will need to be programmed for operation above 60 Hz.

All Pumps in Liters per Hour (lph) Pump					Gear rpm	Motor Ratio	rpm
24 bar	34 bar	103 bar	172 bar	241 bar			
1.567	1.492	1.353	1.221	1.101	15	100:1	1500
1.945	1.852	1.678	1.511	1.350	18.75	80:1	
2.570	2.448	2.218	2.003	1.789	25	60:1	
3.183	3.031	2.751	2.508	2.252	30	50:1	
3.899	3.713	3.435	3.107	2.801	37.5	40:1	
5.276	5.025	4.533	4.129	3.710	50	30:1	
7.658	7.293	6.640	6.069	5.448	75	20:1	
15.426	14.691	13.429	12.110	10.820	150	10:1	
20.390	19.419	17.526	15.974	14.082	200	7.5:1	
30.092*	28.659*	25.810*	23.091*	20.598*	300	5:1	

### Required Motor kW

0.37

\* Flow rates above 30.28 lph are not guaranteed to meet API 675 Performance Standards. To reach a flow rate of 30.28 lph with a 5:1 gear box and 1500 rpm motor, the VFD will need to be programmed for operation above 50 Hz.

#### Please Note:

Systems vary. The MT8 pump must be calibrated once installed to ensure optimum performance. The API 675 Performance Standard is achievable for flow rates as low as 0.06 gph (or 0.227 lph). Please contact the factory for assistance.

# MT8 Pump Performance

## Performance

### Maximum Flow at Designated Pressure for Pumps with Manual Variable Speed Gearbox

- Minimum flow rate of 0.06 gph (0.227 lph) can be achieved at a Manual Dial Setting of 0.1.
- Flow rates above 8 gph (30.28 lph) are not guaranteed to meet API 675 Performance Standards.
- Only use motors with turndown ratios to match the appropriate range of applications.

### Flow Rates in Gallons per Hour (gph)

Manual Dial Setting	All Pumps 350 psi		500 psi		Metalic Pump Heads Only				Motor rpm		
	Flow Rate	rpm	Flow Rate	rpm	1500 psi		2500 psi			3500 psi	
1	1.85	70	1.85	71	1.62	70	1.44	70	1.28	70	1800
2	3.67	144	3.64	144	3.26	143	2.92	143	2.62	143	
3	5.56	213	5.51	214	4.90	213	4.40	212	3.93	211	
4	7.26	280	7.16	281	6.36	278	5.70	278	5.09	277	
5					7.75	343	6.94	342	6.17	341	
6									7.08	405	

Manual Dial Setting to achieve Maximum Flow Rate at pressures shown above										Motor rpm
4.45		4.50		5.17		5.87		6.90		
8.00	310	8.00	315	8.00	354	8.00	399	8.00	462	1800

### Required Motor hp

1/2

### Flow Rates in Liters per Hour (lph)

Manual Dial Setting	All Pumps 24 bar		34 bar		Metalic Pump Heads Only				Motor rpm		
	Flow Rate	rpm	Flow Rate	rpm	103 bar		172 bar			241 bar	
1	5.99	60	5.98	61	5.24	60	4.63	59	4.04	59	1500
2	11.53	121	11.39	121	10.21	120	9.24	120	8.11	120	
3	17.62	179	17.21	179	15.46	178	13.94	178	12.27	177	
4	23.04	234	22.64	235	20.31	233	18.28	232	16.12	231	
5	28.22	288	27.86	289	24.97	286	22.36	286	19.73	285	
6							26.09	339	23.23	338	
7							29.95	392	26.24	391	
8									29.59	444	

Manual Dial Setting to achieve Maximum Flow Rate at pressures shown above										Motor rpm
5.42		5.50		7.00		7.10		8.10		
30.28	310	30.28	315	30.28	355	30.28	397	30.28	448	1500

### Required Motor kW

0.37

# MT8 Pump

Maximum Flow Rate: 8.00 gph (30.28 lph)

Minimum Flow Rate: 0.06 gph (0.227 lph)

Maximum Pressure: 3500 psi (241 bar) for Metallic Pump Heads

350 psi (24 bar) for Non-metallic Pump Heads

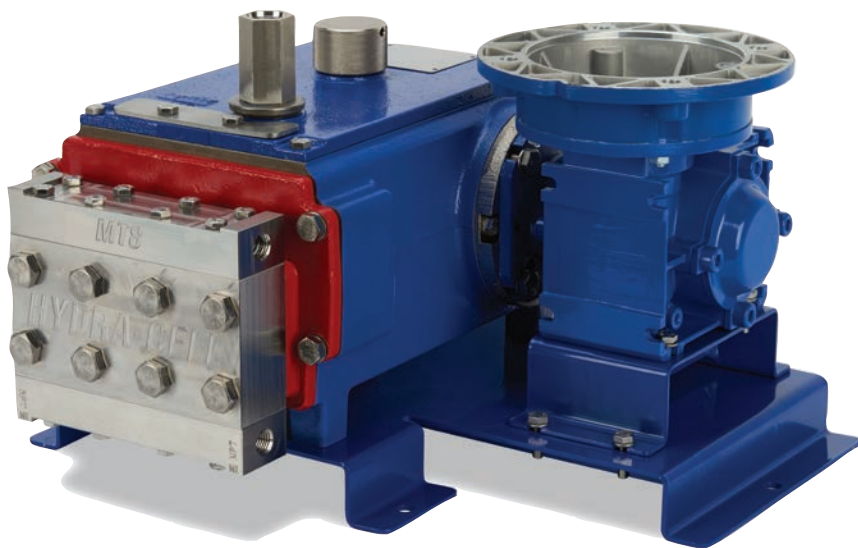

MT8 with Stainless Steel pump head.

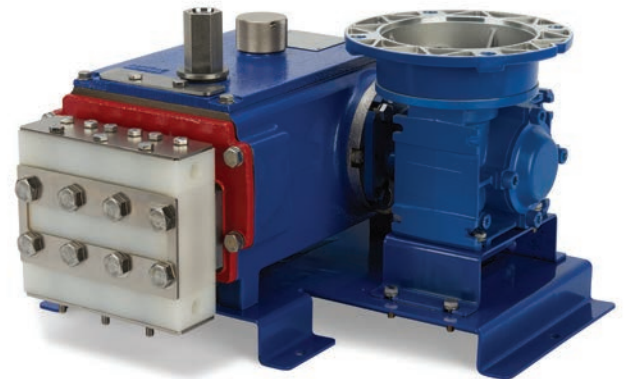

MT8 with PVDF pump head.

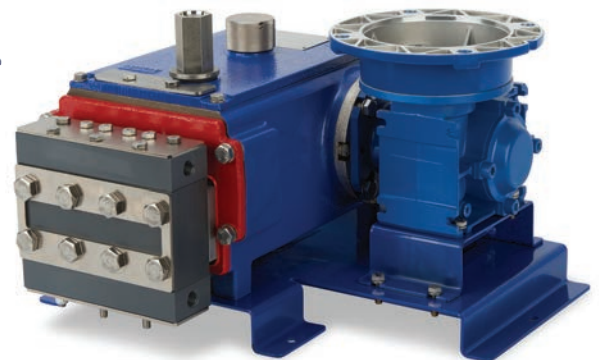

MT8 with PVC pump head.

## Pump Data

Diaphragms per Liquid End	3
Flow Control	Electronic variable speed drive
Maximum Discharge Pressure	
Metallic Heads:	3500 psi (241 bar)
Non-metallic Heads:	350 psi (24 bar)
Maximum Inlet Pressure	
Metallic Heads:	500 psi (34 bar)
Non-metallic Heads:	300 psi (20 bar)
Operating Temperatures (min./max.)	
Metallic Heads:	40 °F (4.4 °C) to 250 °F (121 °C)
Non-metallic Heads:	40 °F (4.4 °C) to 140 °F (60 °C)
<i>Consult factory for temperatures outside this range</i>	
Inlet Port	1/4 inch NPT or BSPT
Discharge Port	1/4 inch NPT or BSPT

Maximum Solids Size	200 microns
Shaft Rotation	Bi-directional
Oil Capacity	1.75 US quarts (1.7 liters)
Suction Lift Capability	20 feet (6.1 meters)
Weight (less motor)	
Metallic Heads:	100 lbs. (45 kg)
Non-metallic Heads:	75 lbs. (34 kg)
Dimensions (less motor)	
<i>For NEMA 56 motor frames only; see page 46 or consult factory for other motor frame sizes.</i>	
Metallic Heads:	15" W x 14.2" D x 9.88" H (381 mm W x 360.68 mm D x 250.95 mm H)
Non-Metallic Heads:	15" W x 14.2" D x 9.88" H (381 mm W x 360.68 mm D x 250.95 mm H)

# MT8 Pump Representative Drawings

## Metallic Pump Heads Inches (mm)

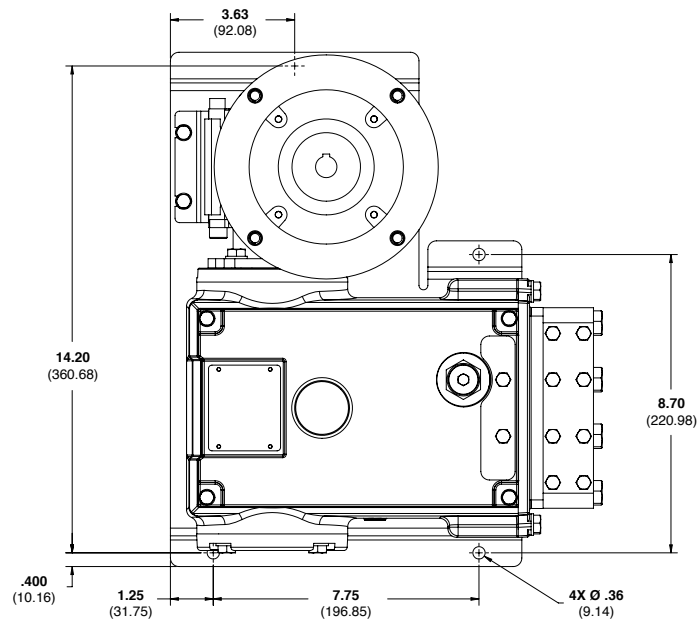

## Metallic Pump Heads with Manual Adjustment Inches (mm)

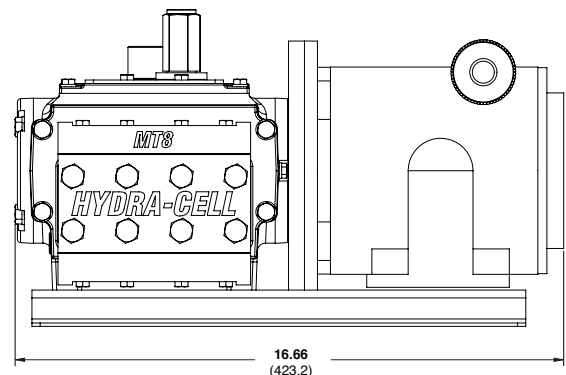
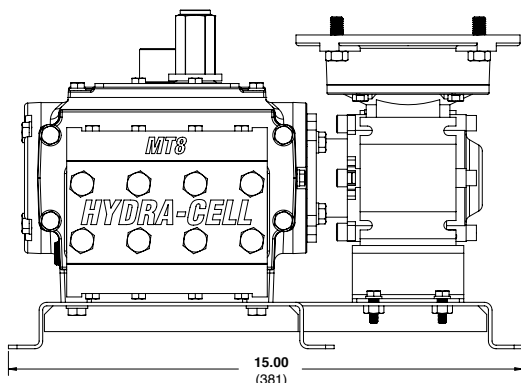
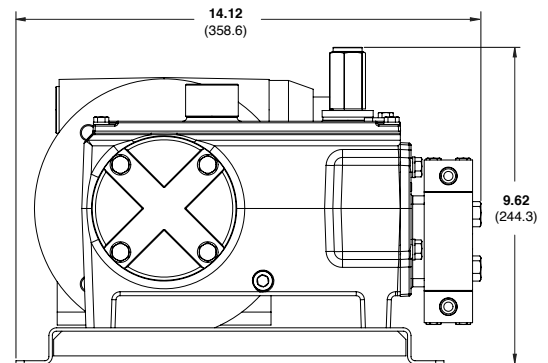
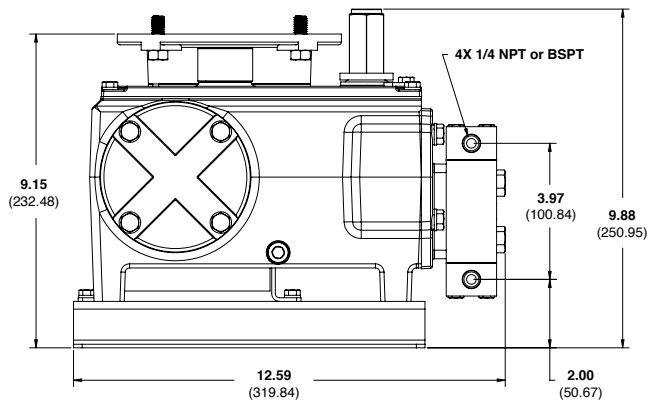
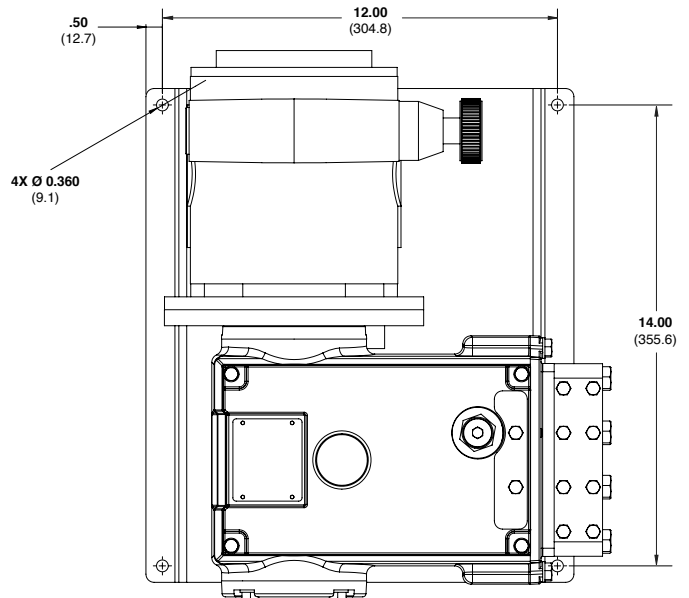

**Note:** Contact factory for additional drawings of specific models and configurations.

# MT8 Pump How to Order

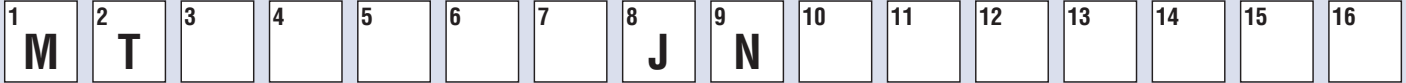

A complete pump order number contains 16 digits based on the specified pump materials listed below.

## Pump Model Size (Digits 1-2)

**MT** Triplex Metering Pumps

## Pump Capacity (Digits 3-4)

**08** 0.06 - 8.00 gph (0.227 - 30.28 lph)

**8D** MT8 Duplex 0.06 - 8.00 (2.227 - 30.28 lph) per pump

## Pump Version (Digit 5)

**N** NPT Ports

**M** BSPT Ports

## Pump Head (Digits 6-7)

**SN** 316 SST

**TN** Hastelloy C

**AN** Alloy 20

**VN** PVC

**MN** PVDF

## Diaphragm (Digit 8)

**J** PTFE

## Leak Detection Style (Digit 9)

**N** No leak detection

## CV Ball/Seat (Digits 10-11)

**SS** 316 SST / 316 SST

**TT** Hastelloy C / Hastelloy C

**AA** Alloy 20 / Alloy 20

## Hydraulic End Oil (Digit 12)

**G** 5W30 (Synthetic oil)

**K** Food-contact oil

## Motor Flange Size (Digit 13)

**A** NEMA 56C

**B** NEMA 143/145TC

**C** IEC 63 B5

**D** IEC 71 B5

**E** IEC 80 B5

**H** NEMA 56C (MA only)

**M** IEC 80 B14 (MA or MX only)

**X** No motor flange

## Gearbox Ratio (Digits 14-15)

**00** 100:1

**80** 80:1

**60** 60:1

**50** 50:1

**40** 40:1

**30** 30:1

**20** 20:1

**10** 10:1

**07** 7.5:1

**05** 5:1

**MA** Manual adjustment  
(specify H or M flange for this option)

**MX** Manual adjustment ATEX  
(specify M flange for this option)

**XX** No gearbox

## Baseplate (Digit 16)

**C** Carbon Steel (Epoxy painted)

**D** Carbon Steel (Epoxy painted) – for Duplex models

**E** SST – for Duplex models

**S** SST

**M** Carbon Steel (Epoxy painted) Manual adjustment

**T** SST Manual adjustment

**X** No baseplate

# Hydra-Cell® S Series Solenoid Metering Pumps

The S Series pumps provide an economical choice for chemical injection in metering applications.

Solenoid driven, the S pumps feature a wide discharge-volume range, extensive choice of liquid end materials, various control functions, and a wide voltage range.

Materials of construction choices and versatile design options result in pumps perfected for specific applications including general chemicals, high-pressure boiler, high-viscosity fluids, outgassing and more.

For complete specifications, performance features, accessories, chemical resistance guide, and other information, request the S Series catalog.

Flow Rate	SM Series Models	SP/ST/SA Series Models
30 ml/min*	SM030	SP/ST/SA-030
60 ml/min	SM060	SP/ST/SA-060
100 ml/min	SM100	SP/ST/SA-100
220 ml/min	N/A	SP/ST/SA-200
<b>With Relief Valve</b>		
30 ml/min*	SM03R	SP/ST/SA-03R
60 ml/min	SM06R	SP/ST/SA-06R
100 ml/min	SM10R	SP/ST/SA-10R

\* High-pressure models have maximum flow rates of either 25 or 28 ml/min. Consult the S Series catalog for more information.



SM030CAS manual control with stroke speed dial.



SP060HVS with pulse-input control and digital readout.



ST03RPES with pulse-input control and digital readout.



SA03RPES with pulse-input/analog-input and digital readout.



Spare parts kits to help extend service life.

S Series solution tanks are available in three sizes to provide compact systems for chemical injection.



30L (7.9 gal)



50L (13.2 gal)



120L (31.7 gal)

# Hydra-Cell® Bare Shaft Pumps for Metering

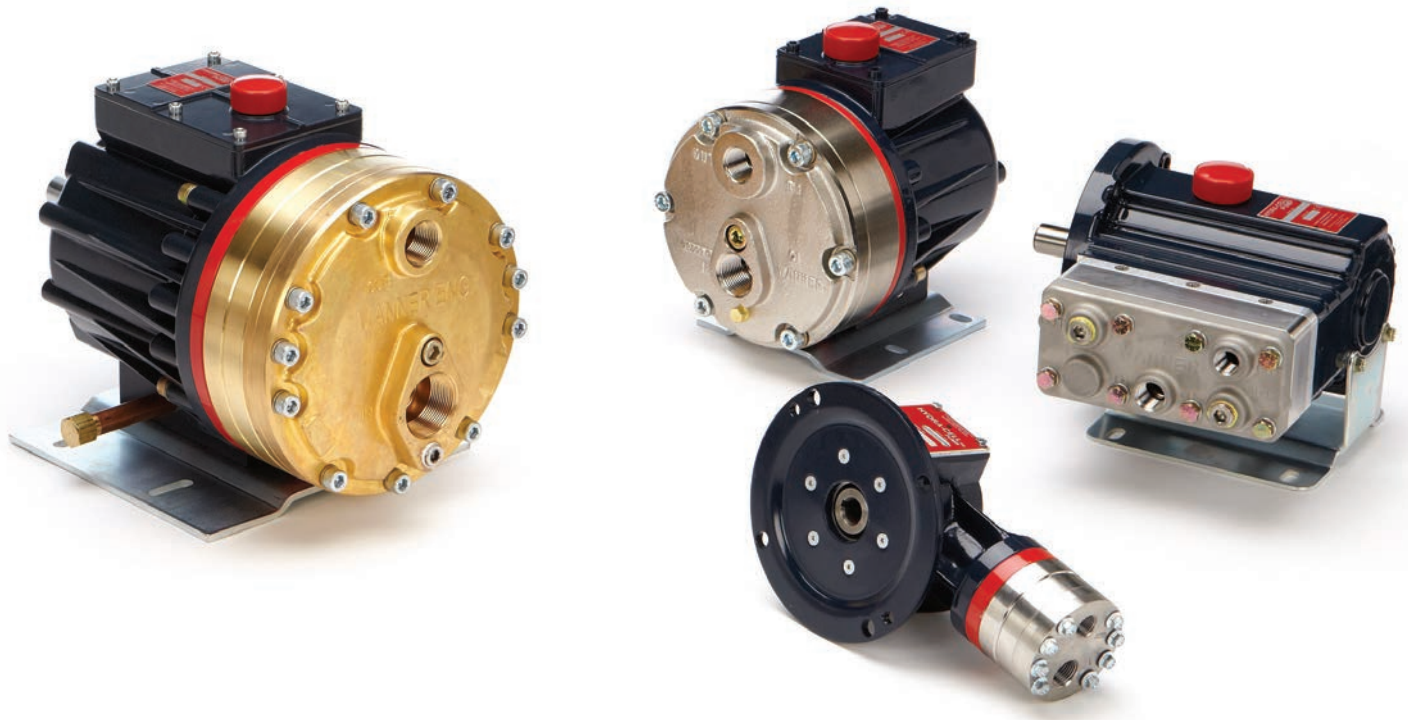

In certain less critical metering and injecting applications, Hydra-Cell Seal-less Pumps (without gearbox reducers) provide an alternative to Hydra-Cell Metering Solutions Pumps. They can meet API 675 performance standards for accuracy, linearity, and repeatability - a must for metering pumps.

Bare shaft pumps also provide linear, virtually pulse-free flow without the use of expensive pulsation dampeners. Hydra-Cell Seal-less Pumps can be used for metering when any of the following conditions apply:

- Flow capacities required exceed those of Hydra-Cell Metering Solutions pumps.
- Meeting API 675 performance standards is not critical to the application.
- Flow rates for the application do not need to be as precise as what Hydra-Cell Metering Solutions pumps deliver.
- Space limitations or application parameters dictate the use of a direct drive or belt drive.

Model <sup>1</sup>	Maximum Capacity gph (lph)	Maximum Discharge Pressure psi (bar)		Maximum Operating Temperature F (C) <sup>3</sup>		Maximum Inlet Pressure psi (bar)	Rated rpm for Metering <sup>4</sup>
		Non-metallic <sup>2</sup>	Metallic	Non-metallic	Metallic		
<b>F20/G20</b>	36.6 (138.5)	350 (24)	1500 (103)	140° (60°)	250° (121°)	250 (17)	1050
<b>D03/G03</b>	155.5 (588.6)	350 (24)	1000 (69)	140° (60°)	250° (121°)	250 (17)	1440
<b>D04/G04</b>	146.9 (556.1)	N/A	2500 (172)	N/A	250° (121°)	500 (34)	1440
<b>D10/G10</b>	483.8 (1831.4)	350 (24)	1000 (69)	140° (60°)	250° (121°)	250 (17)	1440
<b>D15/G15</b>	607.2 (2298.5)	N/A	2500 (172)	N/A	250° (121°)	500 (34)	1150
<b>D15/G15</b>	777.6 (2943.5)	N/A	2000 (138)	N/A	250° (121°)	500 (34)	1440
<b>H25/G25</b>	1197.0 (4531.1)	350 (24)	1000 (69)	140° (60°)	250° (121°)	250 (17)	1050
<b>D35/G35</b>	2186.1 (8275.3)	N/A	1200 (83)	N/A	250° (121°)	500 (34)	1050

1 Ratings are for X-cam design, which must be used for metering.

2 350 psi (24 bar) maximum with PVDF liquid end; 250 psi (17 bar) maximum with Polypropylene liquid end.

3 Consult factory for correct component selection for temperatures from 160°F (71°C) to 250°F (121°C).

4. Do not exceed speeds (rpm) shown.

# Hydra-Cell® Metering Accessories and Options

## System Illustration

Note: Applicable to all P Series pumps and the MT8 pump.

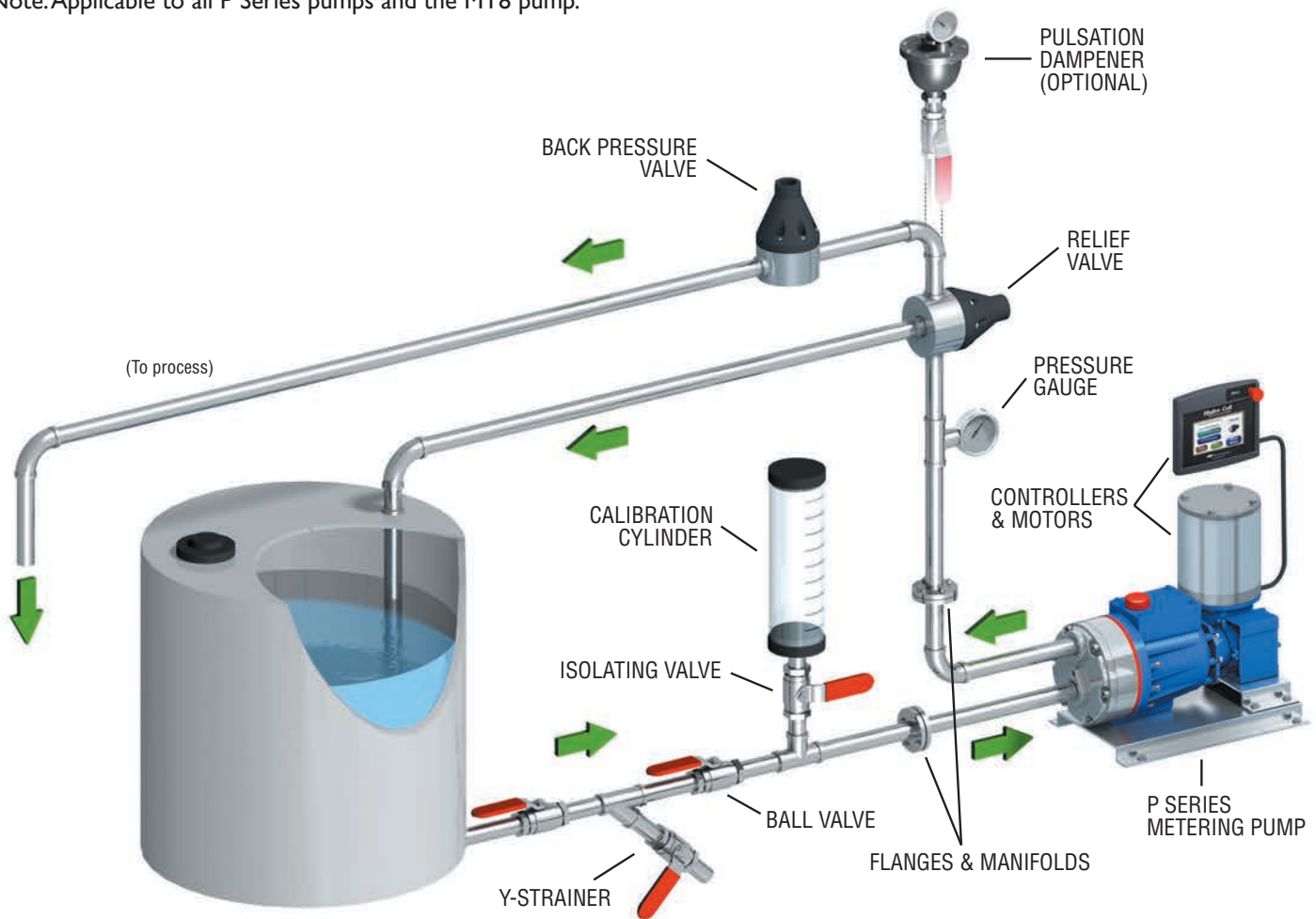

### Accessory/Option

### Page

Pump Configuration .....	53
Actuating Oils .....	53
Motors	
Selection Process .....	54
Motor Frame Guidelines .....	54
Motors/Standard .....	56
Motors/Explosion-proof .....	57
Controllers .....	58
Control Freak Touch-screen Metering Controller .....	59
Calibration Cylinders .....	61

### Accessory/Option

### Page

Pressure Valves	
Dimensions & Port Configurations .....	62
Back Pressure Valves .....	63
Pressure Relief Valves .....	64
Pulsation Dampeners .....	65
Other Services & Support	
Demonstration (Cutaway) Units .....	69
Testing .....	69
System Components, Kits, Plugs, Custom .....	69

## Pump Configuration

### Duplexing

Run two pumps with one gearbox and motor. Ideal for multiple feeds and different manifolds.

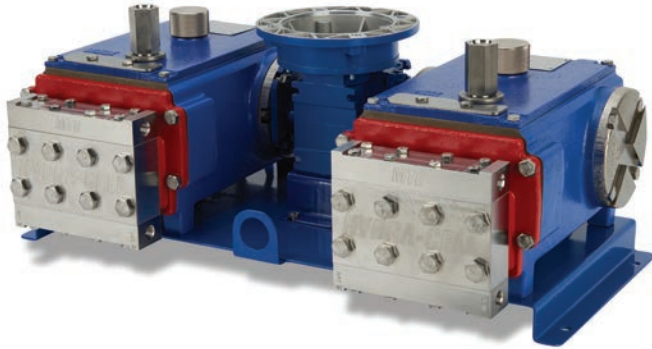

### SmartDrive Motor-Controller

Space-saving, integrated motor and variable speed drive. Eliminates remote mounting and provides convenient operation from one location. Available with NEMA or IEC frames. Optional keypad and network interface.



### Multiplexing Capability

Hydra-Cell Metering Solutions enables mixing ratios of multiple fluids in flexible, economical ways. Using only one motor and one gearbox, Hydra-Cell metering pumps can provide spare, double-flow, side-by-side systems, or pre-mixed ratios. (They need not be the same model Hydra-Cell pumps.)

Up to six different fluids can be metered using different manifold plates. With special manifolds, one P200 or P300 unit can feed up to three systems from one liquid end.



### Base Plates

Base plates are available in epoxy-painted Carbon Steel and (depending on model) 316L Stainless Steel.

### Manifolds and Flanges

Pumps can be fitted with interchangeable metallic or non-metallic pump heads. ANSI, SAE, and DIN flanges are also available.



### Gearbox Ratios

Hydra-Cell Metering Solutions pumps are fitted with interchangeable gearboxes with ratios from 60:1 to 5:1 (P Series) and 100:1 to 5:1 (MT8).



### Oil Systems and Kits

Oil cooler and filter system reduces oil operating temperature, extends oil life, and promotes longevity of pump components.

Oil level monitoring mounting kits detect changes in the oil level to minimize costly interruptions and avoid potential pump damage.

Oil reservoir sight bottles provide additional volume for oil expansion and allow for quick visual inspection of oil.

*For complete details about oil systems and kits, consult the Hydra-Cell Seal-less Pumps master catalog.*

## Actuating Oils

### Hydra-Oil

Formulated to maximize pump performance by reducing wear and maintaining consistent viscosity. See the Hydra-Cell Seal-less Pumps master catalog for details about standard grades, synthetic grades, food-contact grades, and EPDM-compatible grades to suit the process requirement (e.g. temperature, pressure).

### Mesamoll Oil

Mesamoll oil offers outstanding gelling capacity and high saponification resistance along with good dielectric properties and resistance to weathering and light. It is ideal for use with many types of polymers and in instances where it will come into contact with water or an alkali. Mesamoll I oil is a standard offering for P200 model pumps with Aflas diaphragms, PTFE O-rings, and FKM drive case elastomers.

# Motors and Controllers

## Motors

Motors provide the rotary action that operates the gear reducer on a Hydra-Cell Metering Solutions pump. A motor for a specific P Series or MT8 pump model is selected based on the horsepower (hp) or kilowatts (kW), revolutions-per-minute (rpm) and turndown ratio required for the application (performance criteria).

### Selection Process

- Locate the Maximum Estimated Flow (gph or lph) at Designated Pressure (psi or bar) for your application in the Performance table of your Hydra-Cell Metering Solutions pump on the page noted below:
  - P100..... Page 20
  - P200..... Page 24
  - P300..... Page 28
  - P400..... Page 32
  - P500..... Page 36
  - P600..... Page 40
  - MT8..... Pages 45 & 46
- This maximum flow rate corresponds to a color-coded rating of your Required Motor hp or kW.
- Make sure that the hp or kW match the frame and reducer per the chart at right (NEMA motors) or page 55 (IEC motors) for P Series pumps, or page 55 for MT8 pumps.
- Using the charts on pages 56 and 57, for either 1800 rpm or 3600 rpm, select the NEMA motor by matching the Required Motor hp with the correct turndown ratio of your pump.

**Note: for IEC motors, please consult factory.**

## P Series Motor Frame Guidelines (NEMA)

P100	HP	RPM	FRAME	REDUCER CODE
	up to 1	1800	NEMA 56C	0XX
	up to 1	3600	NEMA 56C	0XX
P200	HP	RPM	FRAME	REDUCER CODE
	up to 1	1800	NEMA 56C	0XX
	up to 1	3600	NEMA 56C	0XX
	up to 1-1/2	1800	NEMA 56C	0XX
	up to 1-1/2	3600	NEMA 143/5TC	AXX
P300	HP	RPM	FRAME	REDUCER CODE
	up to 1	1800	NEMA 56C	0XX
	up to 1	3600	NEMA 56C	0XX
	1-1/2 or 2	1800	NEMA 56C	0XX
	1-1/2 or 2	1800	NEMA 143/5TC	AXX
	1-1/2 or 2	3600	NEMA 143/5TC	AXX
	3	3600	NEMA 143/5TC	AXX
P400	HP	RPM	FRAME	REDUCER CODE
	up to 1	1800	NEMA 56C	0XX
	up to 1	3600	NEMA 143/5TC	AXX
	1-1/2 or 2	1800	NEMA 56C	0XX
	1-1/2 or 2	1800	NEMA 143/5TC	AXX
	1-1/2 or 2	3600	NEMA 143/5TC	AXX
	3	3600	NEMA 143/5TC	AXX
P500	HP	RPM	FRAME	REDUCER CODE
	up to 1	1800	NEMA 56C	0XX
	up to 1	3600	NEMA 56C	0XX
	1-1/2 or 2	1800	NEMA 143/5TC	AXX
	1-1/2 or 2	3600	NEMA 143/5TC	AXX
	3 or 5	1800	NEMA 182/4TC	BXX
	3 or 5	3600	NEMA 182/4TC	BXX
	7-1/2 or 10	1800	NEMA 213/5TC	CXX
	7-1/2 or 10	3600	NEMA 213/5TC	CXX
	15	3600	NEMA 254/6TC	DXX
P600	HP	RPM	FRAME	REDUCER CODE
	up to 1	1800	NEMA 56C	0XX
	up to 1	3600	NEMA 143/5TC	AXX
	1-1/2 or 2	1800	NEMA 143/5TC	AXX
	1-1/2 or 2	3600	NEMA 143/5TC	AXX
	3 or 5	1800	NEMA 182/4TC	BXX
	3 or 5	3600	NEMA 182/4TC	BXX
	7-1/2 or 10	1800	NEMA 213/5TC	CXX
	7-1/2 or 10	3600	NEMA 213/5TC	CXX
	15	3600	NEMA 254/6TC	DXX

## P Series Motor Frame Guidelines (IEC)

P100	KW	RPM	FRAME	REDUCER CODE
	up to 0.18	1500	IEC 63 B5	OXX
	up to 0.37	1500	IEC 71 B5	AXX
	up to 0.55	3000	IEC 71 B5	AXX
P200	KW	RPM	FRAME	REDUCER CODE
	up to 0.18	1500	IEC 63 B5	OXX
	up to 0.37	1500	IEC 71 B5	AXX
	up to 0.55	3000	IEC 71 B5	AXX
	up to 0.75	3000	IEC 80 B5	BXX
P300	KW	RPM	FRAME	REDUCER CODE
	up to 0.18	1500	IEC 63 B5	OXX
	up to 0.37	1500	IEC 71 B5	AXX
	up to 0.37	3000	IEC 71 B5	AXX
	up to 0.55	1500	IEC 80 B5	BXX
	up to 0.75	3000	IEC 80 B5	BXX
	up to 1.1	3000	IEC 80 B5	BXX
	up to 1.5	3000	IEC 90 B5	CXX
P400	KW	RPM	FRAME	REDUCER CODE
	up to 0.18	1500	IEC 63 B5	OXX
	up to 0.37	1500	IEC 71 B5	AXX
	up to 0.55	1500	IEC 80 B5	BXX
	up to 0.75	1500	IEC 80 B5	BXX
	up to 1.1	1500	IEC 90 B5	CXX
	up to 0.37	3000	IEC 71 B5	AXX
	up to 0.55	3000	IEC 71 B5	AXX
	up to 0.75	3000	IEC 80 B5	BXX
	up to 1.5	3000	IEC 90 B5	CXX
	up to 2.2	3000	IEC 90 B5	CXX
P500	KW	RPM	FRAME	REDUCER CODE
	up to 0.18	1500	IEC 63 B5	OXX
	up to 0.37	1500	IEC 71 B5	AXX
	up to 0.55	1500	IEC 80 B5	BXX
	up to 0.75	1500	IEC 80 B5	BXX
	up to 1.1	1500	IEC 90 B5	CXX
	up to 1.5	1500	IEC 90 B5	CXX
	up to 2.2	1500	IEC 100 B14	DXX
	up to 4	1500	IEC 112 B14	DXX
	up to 0.75	3000	IEC 80 B5	BXX
	up to 1.1	3000	IEC 80 B5	BXX
	up to 1.5	3000	IEC 90 B5	CXX
	up to 2.2	3000	IEC 90 B5	CXX
	up to 4	3000	IEC 112 B14	DXX
P600	KW	RPM	FRAME	REDUCER CODE
	up to 0.18	1500	IEC 63 B5	OXX
	up to 0.37	1500	IEC 71 B5	AXX
	up to 0.55	1500	IEC 80 B5	BXX
	up to 0.75	1500	IEC 80 B5	BXX
	up to 1.1	1500	IEC 90 B5	CXX
	up to 1.5	1500	IEC 90 B5	CXX
	up to 2.2	1500	IEC 100 B14	DXX
	up to 4	1500	IEC 112 B14	DXX
	up to 0.75	3000	IEC 80 B5	BXX
	up to 1.1	3000	IEC 80 B5	BXX
	up to 1.5	3000	IEC 90 B5	CXX
	up to 2.2	3000	IEC 90 B5	CXX
	up to 4	3000	IEC 112 B14	DXX

## MT8 Motor Frame Guidelines (NEMA)

MT8	HP	RPM	FRAME	REDUCER CODE
	up to 1/2	1800	NEMA 56C	XX
	up to 1/2	1800	NEMA 56C	MA
	up to 1/2	1800	NEMA 143/5TC	XX

## MT8 Motor Frame Guidelines (IEC)

MT8	KW	RPM	FRAME	REDUCER CODE
	up to 0.37	1500	IEC 63 B5	XX
	up to 0.37	1500	IEC 71 B5	XX
	up to 0.37	1500	IEC 80 B5	XX
	up to 0.37	1500	IEC 80 B14	MA or MX

## Motors

### 1800 rpm Inverter Duty - 3 Phase

HP	Voltage	Turndown Ratio	Frame	Enclosure	Drip Cover	Part Number	Weight (lbs.)
1/4	230	1000:1	56C	TENV		M25TE18-3P56C	18
1/2	230/460	1000:1	56C	TENV		M50TE18-3P56C	20
1/2	230/460	10:1	56C	TEFC		M50TE18R3P56CA3	34
3/4	230/460	20:1	56C	TEFC		M75TE18R3P56CA4	21
1	230/460	10:1	143TC	TEFC	Yes	M100TE18R3P143TCA3	59
1	230/460	1000:1	143TC	TENV*		M100TN18R3P143TCA5	50
1-1/2	230/460	2:1	56C	TEFC		M150TE183P56CP	29
1-1/2	230/460	10:1	145TC	TEFC	Yes	M150TE18R3P145TCA3	38
1-1/2	230/460	1000:1	145TC	TENV*		M150TN18R3P145TCA5	48
2	230/460	4:1	56C	TEFC*		M200TE18R3P56CA2	41
2	230/460	10:1	145TC	TEFC	Yes	M200TE18R3P145TCA3	44
2	230/460	20:1	145TC	TEFC		M200TE18R3P145TCA4	51
3	230/460	10:1	182TC	TEFC	Yes	M300TE18R3P182TCA3	125
3	230/460	20:1	182TC	TEFC		M300TE18R3P182TCA4	86
5	230/460	10:1	184TC	TEFC	Yes	M500TE18R3P184TCA3	125
5	230/460	20:1	184TC	TEFC		M500TE18R3P184TCA4	88
7-1/2	230/460	10:1	213TC	TEFC	Yes	M750TE18R3P213TCA3	185
7-1/2	230/460	20:1	213TC	TEFC		M750TE18R3P213TCA4	98
10	230/460	10:1	215TC	TEFC	Yes	M1000TE18R3P215TCA3	185
10	230/460	20:1	215TC	TEFC		M1000TE18R3P215TCA4	125
15	230/460	10:1	254TC	TEFC	Yes	M1500TE18R3P254TCA3	310

\* With Removable Feet

Use washdown or motors with a drip cover for outside installations.

If operating under 6 HZ (greater than 10:1 turndown ratio) consult factory.

### 3600 rpm Inverter Duty - 3 Phase

HP	Voltage	Turndown Ratio	Frame	Enclosure	Drip Cover	Part Number	Weight (lbs.)
1	230/460	10:1	56C	TEFC		M100TE36R3P56CA3	34
1	230/460	10:1	143TC	TEFC	Yes	M100TE36R3P143TCA3	59
1-1/2	230/460	10:1	143TC	TEFC	Yes	M150TE36R3P143TCA3	59
2	230/460	10:1	145TC	TEFC	Yes	M200TE36R3P145TCA3	65
3	230/460	10:1	182TC	TEFC	Yes	M300TE36R3P182TCA3	100
5	230/460	10:1	184TC	TEFC	Yes	M500TE36R3P184TCA3	120
7-1/2	230/460	10:1	213TC	TEFC	Yes	M750TE36R3P213TCA3	175
10	230/460	10:1	215TC	TEFC	Yes	M1000TE36R3P215TCA3	198
15	230/460	10:1	254TC	TEFC	Yes	M1500TE36R3P254TCA3	310

Use washdown or motors with a drip cover for outside installations.

If operating under 6 HZ (greater than 10:1 turndown ratio) consult factory.

## Explosion-proof Motors

Consult the National Electric Code and your local regulations for proper selection of motors in hazardous locations.

### Hazardous-duty Location, NEMA 56C, Footed, 3 Phase

HP	RPM	Frame	Part Number	Turndown Ratio (CT)	Enclosure	Voltage/Hz	Weight (lbs.)
1/4	1800	56C	M25EX18F3P56CA5	1000:1	TENV	230-460/60	26
1/2	1800	56C	M50EX18F3P56CA5	1000:1	TENV	230-460/60	31
3/4	1800	56C	M75EX18F3P56CA5	1000:1	TENV	230-460/60	38
1	1800	56C	M100EX18F3P56CA5	1000:1	TENV	230-460/60	43

If operating under 6 HZ (greater than 10:1 turndown ratio) consult factory.

#### Standard Features:

- Class I and II, Groups C, D, F & G.
- CSA certified.
- UL listed.
- Continuous duty at 104°F (40°C) ambient.

### Hazardous-duty Location, No Feet, 3 Phase

HP	RPM	Frame	Part Number	Turndown Ratio (CT) <sup>(1)</sup>	Shipping Weight (lbs.)
1	1800	143TC	M100EX18R3P143TCA2	4:1	68
2	3600	145TC	M200EX36R3P145TCA2	4:1	110
2	1800	145TC	M200EX18R3P145TCA2	4:1	110
3	3600	182TC	M300EX36R3P182TCA2	4:1	150
3	1800	182TC	M300EX18R3P182TCA2	4:1	150
5	3600	184TC	M500EX36R3P184TCA2	4:1	170
5	1800	184TC	M500EX18R3P184TCA2	4:1	160
7.5	3600	213TC	M750EX36R3P213TCA2	4:1	230
7.5	1800	213TC	M750EX18R3P213TCA2	4:1	250
10	3600	215TC	M1000EX36R3P215TCA2	4:1	285
10	1800	215TC	M1000EX18R3P215TCA2	4:1	325

Consult factory if higher turndown ratios are required.

Consult factory if operating above 3,300 ft. (1,006 m) elevation.

#### Standard Features:

- Totally enclosed fan cooled - explosion proof (IP55), continuous-duty, 230/460 V, 60 Hz, 3 phase.
- 1.15 service factor (1.0 when operated with a VFD).
- UL and CSA listed for Class I, Division I, Group C & D and Class II, Groups E, F, G: Temp Code T3B.
- Cast-iron construction, premium efficiency.
- UL listed for inverter duty.
- Class "F" insulation with Class "B" rise.

Available with ATEX certification - consult factory.

## Variable Frequency Drives (VFD) and Controllers

Hydra-Cell Metering Solutions pumps feature VFD electronic controllers to regulate the motor speed and strokes-per-minute, providing a flow that is proportional to the motor speed. They are selected based on the motor hp and whether single-phase or three-phase voltage is required.

### Selection Process

1. Ensure that the phase and enclosure match your application.
2. Using the appropriate chart below, select the controller hp based on the hp of your motor.
3. Match the output voltage to the output voltage of your motor.
4. Match the input voltage to your electrical source.



### 1 Phase

HP	Type	Voltage (input/output)	Enclosure	Part Number	Weight (lbs.)
1/2	Sensorless Vector	230 volt / 230 volt	NEMA 1	C50N1-1P3P-230	2.2
1	Sensorless Vector	115 volt / 230 volt	IP-20	C100IP-1P3P-115	3.5
1	Micro AC Inverter	115 volt / 230 volt	NEMA 4	C100N4-1P3P-115	8.0
1	Sensorless Vector	230 volt / 230 volt	NEMA 1	C100N1-1P3P-230	2.2
1	Sensorless Vector	230 volt / 230 volt	NEMA 4	C100N4-1P3P-230	8.0
2	Sensorless Vector	230 volt / 230 volt	NEMA 1	C200N1-1P3P-230	4.4
3	Sensorless Vector	230 volt / 230 volt	NEMA 1	C300N1-1P3P-230	4.4

### 3 Phase

HP	Type	Voltage (input/output)	Enclosure	Part Number	Weight (lbs.)
1/2	Sensorless Vector	230 volt / 230 volt	NEMA 1	C50N1-3P3P-230	2.2
1	Sensorless Vector	230 volt / 230 volt	NEMA 1	C100N1-3P3P-230	2.2
2	Sensorless Vector	230 volt / 230 volt	NEMA 1	C200N1-3P3P-230	4.4
2	Micro AC Inverter	230 volt / 230 volt	NEMA 4	C200N4-3P3P-230	14.0
3	Sensorless Vector	230 volt / 230 volt	NEMA 1	C300N1-3P3P-230	4.4
5	Sensorless Vector	230 volt / 230 volt	NEMA 1	C500N1-3P3P-230	5.0
7-1/2	Sensorless Vector	230 volt / 230 volt	NEMA 1	C750N1-3P3P-230	13.0
10	Sensorless Vector	230 volt / 230 volt	NEMA 1	C1000N1-3P3P-230	13.0
1	Sensorless Vector	460 volt / 460 volt	NEMA 1	C100N1-3P3P-460	2.2
1	Micro AC Inverter	460 volt / 460 volt	NEMA 4	C100N4-3P3P-460	13.0
2	Sensorless Vector	460 volt / 460 volt	NEMA 1	C200N1-3P3P-460	2.2
2	Micro AC Inverter	460 volt / 460 volt	NEMA 4	C200N4-3P3P-460	14.0
3	Sensorless Vector	460 volt / 460 volt	NEMA 1	C300N1-3P3P-460	4.4
5	Sensorless Vector	460 volt / 460 volt	NEMA 1	C500N1-3P3P-460	4.4
7-1/2	Sensorless Vector	460 volt / 460 volt	NEMA 1	C750N1-3P3P-460	14.0
10	Sensorless Vector	460 volt / 460 volt	NEMA 1	C1000N1-3P3P-460	14.0
15	Sensorless Vector	460 volt / 460 volt	NEMA 1	C1500N1-3P3P-460	14.0
20	Sensorless Vector	460 volt / 460 volt	NEMA 1	C2000N1-3P3P-460	28.0
30	Sensorless Vector	460 volt / 460 volt	NEMA 1	C3000N1-3P3P-460	30.0

# Control Freak™ Touch-screen Metering Controller



Start-up menu options.

“Control Freak” is an exclusive new electronic controller that provides motor speed control for Hydra-Cell Metering Solutions pumps (or select Hydra-Cell bare shaft pumps) with an easy-to-use touch-screen display and built-in programming.

The user can enter the desired flow rate or volume in gallons or liters and system pressure in psi or bar; and the controller automatically runs the pump manually at desired flow rate or volume total/time, or in pre-set batches.

The versatile Control Freak enables programming for the flow rate or for totalization of the recent process application as well as the life of the pump.



Opening screen - touch to activate.



Sample menu for batch operation.

## Performance Features

- Features a Variable Frequency Drive (VFD) available in different hp (or kW) ratings
- Pre-set (with password protection) for Hydra-Cell pump performance algorithms - can also be field-calibrated for greater accuracy
- 7” color graphic touch-screen user interface in a NEMA-4X (or IP) enclosure - easy to operate and visible in low-light areas
- Safety features for emergency stop, loss of power and fault monitoring
- Pump-drive information screen
- Four configurable on-off relays
- Ten separate batch set-up screens
- Two user-configurable analog input displays
- Analog and digital I/O for interfacing with external devices
- One analog input dedicated to a pre-programmed closed loop feedback
- Includes real-time clock
- Versatile - enables programming for flow rate or totalization
- Can control up to six (6) pumps with one Hydra-Cell Control Freak screen - requires additional VFDs and I/O modules

## Options

- Ball-mount assembly for touch screen
- VFD enclosure
- Additional cables
- Oil temperature probe kit

## Control Freak Selection Process

Control Freak enables control of up to six pumps from one touch-screen. A complete Control Freak unit is comprised of Touch-screen Kit (Number 150-150) plus one or more VFD kits.

### Touch-screen Kit (required)

Kit Number	Contents
150-150	7" Touch-screen Assembly Cable, CAT5e, 7-ft.

#### Each VFD kit includes:

- Appropriate VFD model in chart below
- I/O Module, Single Pump
- Wiring, I/O Module
- Wiring, Motor, 22 ga., 1-ft., Red
- Wiring, Motor, 22 ga., 1-ft., White
- Cable, CAT5e, 1-ft.



### VFD Kits (order one VFD kit for each pump operated by the Control Freak)

Power	Type	Input Voltage/Phase	Output Voltage/Phase	Kit Number
1/2 hp (0.37 kW)	VFD	115 volt/1-phase	230 volt/3-phase	150-250
1/2 hp (0.37 kW)	VFD	230 volt/1-phase	230 volt/3-phase	150-251
1 hp (0.75 kW)	VFD	115 volt/1-phase	230 volt/3-phase	150-252
1 hp (0.75 kW)	VFD	230 volt/1-phase	230 volt/3-phase	150-253
2 hp (1.5 kW)	VFD	230 volt/1-phase	230 volt/3-phase	150-254
3 hp (2.2 kW)	VFD	230 volt/1-phase	230 volt/3-phase	150-255
1/2 hp (0.37 kW)	VFD	230 volt/3-phase	230 volt/3-phase	150-256
1 hp (0.75 kW)	VFD	230 volt/3-phase	230 volt/3-phase	150-257
2 hp (1.5 kW)	VFD	230 volt/3-phase	230 volt/3-phase	150-258
3 hp (2.2 kW)	VFD	230 volt/3-phase	230 volt/3-phase	150-259
1 hp (0.75 kW)	VFD	460 volt/3-phase	460 volt/3-phase	150-264
2 hp (1.5 kW)	VFD	460 volt/3-phase	460 volt/3-phase	150-265
3 hp (2.2 kW)	VFD	460 volt/3-phase	460 volt/3-phase	150-266

For higher hp or kW, please consult factory.

### Control Freak Accessories

Accessory	Description	Part Number
Enclosure (1)	VFD Enclosure for up to 1 hp (0.75 kW)	150-005
Probe Kit	Oil Temperature Sensor Probe with Oil Cap	150-006
Ball Mount Assembly	Bracket Ball, Ball Mount Hinge, Screw, Nut	150-030
Cabling	1-ft. CAT5e Cable	150-401
Cabling	3-ft. CAT5e Cable	150-403
Cabling	7-ft. CAT5e Cable	150-407
Cabling	10-ft. CAT5e Cable	150-410
Cabling	30-ft. CAT5e Cable	150-430

(1) Consult factory for larger VFDs and for pricing on equipment mounting in enclosure.



# Calibration Cylinders

The calibration cylinder verifies the flow rate of your Hydra-Cell metering pump, providing a visual indicator that your system is operating within the required parameters for performance and accuracy.

Available in PVC and glass, calibration cylinders are selected based on cylinder capacity needed (gph or lph) as determined by the maximum shaft rpm of your pump. Models are available for both NPT and BSPT ports.

## Selection Process

1. Size the appropriate model pump to the application (refer to pump specifications for complete information).
2. Use the application rpm to select the appropriate cylinder from the chart below.



Cylinder Size							
mL	30	200	300	1000	2000	10000	
Capacity							
gph	0.95	6.4	9.5	32	64	320	
lph	3.6	24	36	120	240	1200	
Pump Model*	Maximum Pump Shaft (rpm)						
MT8	36	250	360	-	-	-	
P100 (F20)	30	180	250	1000	1750	-	
P200 (M03)	-	60	90	300	600	1750	
P300 (D04)	-	60	90	300	600	1750	
P400 (D10)	-	30	40	110	210	1000	
P500 (D15/D17)	-	-	-	60	115	600	
P600 (H25)	-	-	-	30	60	275	

\*Corresponding Bare Shaft Pump model from page 51 shown in parentheses.

Port C	Cylinder Size (mL)	Part Number		Dimensions - in (mm)	
		NPT Ports	BSPT Ports	A	B
<b>PVC Cylinders</b>					
1/2"	200	111-001	111-001-B	19.0 (482.6)	1.5 (38.1)
1/2"	300	111-002	111-002-B	13.0 (330.2)	2.2 (55.9)
3/4"	1000	111-003	111-003-B	22.0 (558.8)	2.5 (63.5)
1"	2000	111-004	111-004-B	20.0 (508.0)	3.7 (94.0)
2"	10000	111-006	111-006-B	25.0 (635.0)	6.95 (176.5)
<b>Glass Cylinders</b>					
1/4"	30	111-010	111-010-B	14.0 (355.6)	1.4 (35.6)
1/2"	200	111-011	111-011-B	21.0 (533.4)	2.5 (63.5)
3/4"	1000	111-013	111-013-B	27.0 (685.8)	3.5 (88.9)
1"	2000	111-014	111-014-B	27.0 (685.8)	5.0 (127.0)

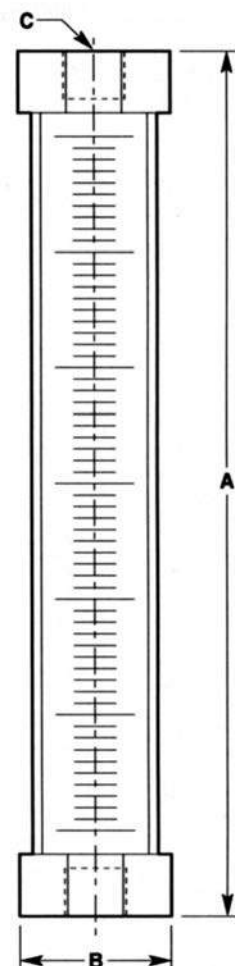

# Back Pressure and Pressure Relief Valves

Back pressure valves help ensure that your Hydra-Cell metering pump provides accurate and predictable flow. Pressure relief valves protect your pump and system from over-pressurized situations.

Available in a choice of wetted materials with PTFE diaphragms, pressure valves are selected according to the valve port size needed for the appropriate maximum flow (gph or lph) of your Hydra-Cell metering pump. Models are available for both NPT and BSPT ports.



## Dimensions and Port Configurations

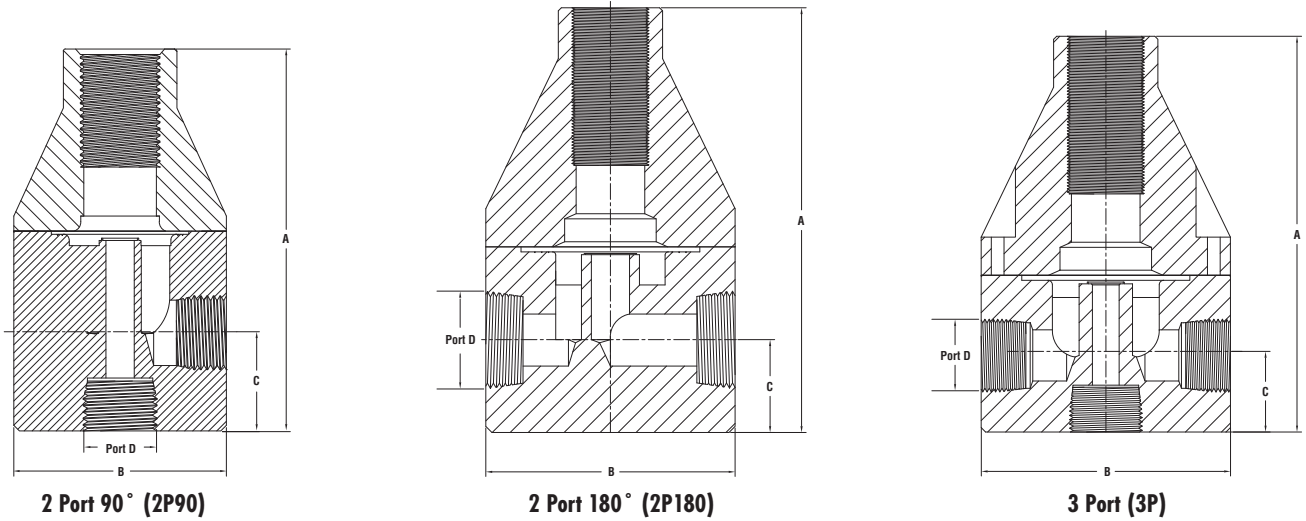

Material	Port D	A		B		C	
		in	mm	in	mm	in	mm
Polypropylene/PVDF	3/8" (DN 10) LoFlo	3.55	90.2	2.35	59.7	0.75	19.1
	1/2" (DN 15) LoFlo	4.25	108.0	2.35	59.7	1.08	27.4
	3/4" (DN 20)*	5.56	141.2	3.50	88.9	1.125	28.6
	1" (DN 25) StdFlo	5.86	148.8	3.50	88.9	1.25	31.8
	1" (DN 25) HiFlo	7.25	184.2	4.90	124.5	1.25	31.8
	2" (DN 50) StdFlo	8.90	226.1	4.90	124.5	2.15	54.6
316 SST	1/4" (DN 8) High Pressure	4.25	108.0	2.35	59.7	1.08	27.4
	1/4" (DN 8) Super High Pressure (HP)	4.72	119.9	2.375	60.3	1.08	27.4
	3/8" (DN 10) LoFlo	3.55	90.2	2.35	59.7	0.75	19.1
	3/8" (DN 10) High Pressure	4.25	108.0	2.35	59.7	1.08	27.4
	1/2" (DN 15) LoFlo	4.25	108.0	2.35	59.7	1.08	27.4
	1/2" (DN 15) High Pressure	4.25	108.0	2.35	59.7	1.08	27.4
	1/2" (DN 15) Super High Pressure (HP)	4.72	119.9	2.375	60.3	1.08	27.4
	3/4" (DN 20)*	5.56	141.2	3.50	88.9	1.125	28.6
	1" (DN 25) StdFlo	5.86	148.8	3.50	88.9	1.25	31.8
	1" (DN 25) HiFlo	7.25	184.2	4.90	124.5	1.25	31.8
	1" (DN 25) High Pressure	5.90	149.9	3.50	88.9	1.25	31.8
	2" (DN 50) StdFlo	8.90	226.1	4.90	124.5	2.15	54.6
Hastelloy C	1/4" (DN 8) High Pressure	4.25	108.0	2.35	59.7	1.08	27.4
	1/4" (DN 8) Super High Pressure (HP)	4.72	119.9	2.375	60.3	1.08	27.4
	3/8" (DN 10) LoFlo	3.55	90.2	2.35	59.7	0.75	19.1
	3/8" (DN 10) High Pressure	4.25	108.0	2.35	59.7	1.08	27.4
	1/2" (DN 15) LoFlo	4.25	108.0	2.35	59.7	1.08	27.4
	1/2" (DN 15) High Pressure	4.25	108.0	2.35	59.7	1.08	27.4
	1/2" (DN 15) Super High Pressure (HP)	4.72	119.9	2.375	60.3	1.08	27.4
	3/4" (DN 20)*	5.56	141.2	3.50	88.9	1.125	28.6
	1" (DN 25) StdFlo	5.86	148.8	3.50	88.9	1.25	31.8
	1" (DN 25) HiFlo	7.25	184.2	4.90	124.5	1.25	31.8
	1" (DN 25) High Pressure	5.90	149.9	3.50	88.9	1.25	31.8
	2" (DN 50) StdFlo	8.90	226.1	4.90	124.5	2.15	54.6

\* 3/4" (DN 20) dimensions apply to StdFlo, HiFlo, and High Pressure models.

# Back Pressure Valves

## Selection Process

1. Use the Valve Port Size “D” chart below to determine the valve port size with the appropriate maximum flow rate to match the Hydra-Cell pump selected; gpm and l/min are Continuous Flow; gph and lph are Pulsating Flow.

2. For Back Pressure Valves, use the chart on this page to select the appropriate valve. For Pressure Relief Valves, use the chart on the following page.

(Note: The maximum flow rates are guidelines. Consult factory for specific recommendations.)

## Valve Port Size “D”

		LoFlo		StdFlo			HiFlo		High Pressure		Super High Pressure
		3/8"	1/2"	3/4"	1"	2"	3/4"	1"	1/4"-3/8"-1/2"	3/4"-1"	1/4"-1/2"
<b>Maximum Flow</b>		<b>(DN 10)</b>	<b>(DN 15)</b>	<b>(DN 20)</b>	<b>(DN 25)</b>	<b>(DN 50)</b>	<b>(DN 20)</b>	<b>(DN 25)</b>	<b>(DN 8/DN 10/DN 15)</b>	<b>(DN 20/DN 25)</b>	<b>(DN 8/DN 10)</b>
Continuous	gpm	10	15	21	26	120	30	54	35	60	56
	l/min	37	57	80	98	454	114	204	132	227	212
Pulsating	gph	200	300	300	500	2350	600	1000	700	1200	1050
	lph	757	1135	1135	1890	8892	2271	3785	2650	4542	3975

Pulsating recommended for single-diaphragm P100.

Port “D”	Wetted Materials*	Pressure Adjustment Range		Maximum Temperature		Port Configuration	Part Number	
		psi	bar	°F	°C		NPT Ports	BSPT Ports
3/8" (DN 10)	Polypropylene	10 - 150	0.7 - 10.3	195	90	2P180	111-101	111-101-B
LoFlo	PVDF	10 - 150	0.7 - 10.3	300	149	2P180	111-103	111-103-B
	316 SST	10 - 150	0.7 - 10.3	300	149	2P180	111-106	111-106-B
	Hastelloy C	10 - 150	0.7 - 10.3	300	149	2P180	111-110	111-110-B
	316 SST	50 - 350	3.5 - 24	300	149	2P180	111-107	111-107-B
	Hastelloy C	50 - 350	3.5 - 24	300	149	2P180	111-111	111-111-B
1/2" (DN 15)	Polypropylene	10 - 150	0.7 - 10.3	195	90	2P180	111-121	111-121-B
LoFlo	PVDF	10 - 150	0.7 - 10.3	300	149	2P180	111-123	111-123-B
	316 SST	10 - 150	0.7 - 10.3	300	149	2P180	111-126	111-126-B
	Hastelloy C	10 - 150	0.7 - 10.3	300	149	2P180	111-130	111-130-B
	316 SST	50 - 350	3.5 - 24	300	149	2P180	111-127	111-127-B
	Hastelloy C	50 - 350	3.5 - 24	300	149	2P180	111-131	111-131-B
3/4" (DN 20)	Polypropylene	10 - 150	0.7 - 10.3	195	90	2P180	111-341	111-341-B
StdFlo	PVDF	10 - 150	0.7 - 10.3	300	149	2P180	111-343	111-343-B
	316 SST	10 - 150	0.7 - 10.3	300	149	2P180	111-346	111-346-B
	Hastelloy C	10 - 150	0.7 - 10.3	300	149	2P180	111-350	111-350-B
	316 SST	50 - 350	3.5 - 24	300	149	2P180	111-267	111-267-B
1" (DN 25)	Polypropylene	10 - 150	0.7 - 10.3	195	90	2P180	111-261	111-261-B
StdFlo	PVDF	10 - 150	0.7 - 10.3	300	149	2P180	111-263	111-263-B
	316 SST	10 - 150	0.7 - 10.3	300	149	2P180	111-266	111-266-B
	Hastelloy C	10 - 150	0.7 - 10.3	300	149	2P180	111-270	111-270-B
	316 SST	50 - 350	3.5 - 24	300	149	2P180	111-267	111-267-B
	Hastelloy C	50 - 350	3.5 - 24	300	149	2P180	111-271	111-271-B
	316 SST	50 - 350	3.5 - 24	300	149	2P180	111-287	111-287-B
1" (DN 25)	Polypropylene	10 - 150	0.7 - 10.3	195	90	2P180	111-361	111-361-B
HiFlo	PVDF	10 - 150	0.7 - 10.3	300	149	2P180	111-363	111-363-B
	316 SST	10 - 150	0.7 - 10.3	300	149	2P180	111-366	111-366-B
	Hastelloy C	10 - 150	0.7 - 10.3	300	149	2P180	111-370	111-370-B
2" (DN 50)	Polypropylene	10 - 150	0.7 - 10.3	195	90	2P180	111-281	111-281-B
StdFlo	PVDF	10 - 150	0.7 - 10.3	300	149	2P180	111-283	111-283-B
	316 SST	10 - 150	0.7 - 10.3	300	149	2P180	111-286	111-286-B
	Hastelloy C	10 - 150	0.7 - 10.3	300	149	2P180	111-290	111-290-B
	316 SST	50 - 350	3.5 - 24	300	149	2P180	111-287	111-287-B
	Hastelloy C	50 - 350	3.5 - 24	300	149	2P180	111-291	111-291-B

\* Diaphragm material is PTFE on all models. Other materials available on request.

## Pressure Relief Valves

Port "D"	Wetted Materials*	Pressure Adjustment Range		Maximum Temperature		Port Configuration	Part Number	
		psi	bar	°F	°C		NPT Ports	BSPT Ports
1/4" (DN 8)	316 SST	350 - 2500	24 - 172	300	149	2P90	111-800	111-800-B
High Pressure	Hastelloy C	350 - 2500	24 - 172	300	149	2P90	111-804	111-804-B
1/4" (DN 8)	316 SST	1000 - 4000	69 - 275	300	149	2P90	111-780	111-780-B
Super HP	Alloy 20	1000 - 4000	69 - 275	300	149	2P90	111-781	111-781-B
	Hastelloy C	1000 - 4000	69 - 275	300	149	2P90	111-782	111-782-B
3/8" (DN 10)	Polypropylene	10 - 150	0.7 - 10.3	195	90	3P	111-401	111-401-B
LoFlo	PVDF	10 - 150	0.7 - 10.3	300	149	3P	111-403	111-403-B
	316 SST	10 - 150	0.7 - 10.3	300	149	3P	111-406	111-406-B
	Hastelloy C	10 - 150	0.7 - 10.3	300	149	3P	111-410	111-410-B
	316 SST	50 - 350	3.5 - 24	300	149	3P	111-407	111-407-B
	Hastelloy C	50 - 350	3.5 - 24	300	149	3P	111-411	111-411-B
3/8" (DN 10)	316 SST	350 - 2500	24 - 172	300	149	2P90	111-706	111-706-B
High Pressure	Hastelloy C	350 - 2500	24 - 172	300	149	2P90	111-710	111-710-B
1/2" (DN 15)	Polypropylene	10 - 150	0.7 - 10.3	195	90	3P	111-421	111-421-B
LoFlo	PVDF	10 - 150	0.7 - 10.3	300	149	3P	111-423	111-423-B
	316 SST	10 - 150	0.7 - 10.3	300	149	3P	111-426	111-426-B
	Hastelloy C	10 - 150	0.7 - 10.3	300	149	3P	111-430	111-430-B
	316 SST	50 - 350	3.5 - 24	300	149	3P	111-427	111-427-B
	Hastelloy C	50 - 350	3.5 - 24	300	149	3P	111-431	111-431-B
1/2" (DN 15)	316 SST	350 - 2500	24 - 172	300	149	2P90	111-726	111-726-B
High Pressure	Hastelloy C	350 - 2500	24 - 172	300	149	2P90	111-730	111-730-B
1/2" (DN 15)								
Super HP	316 SST	1000 - 4000	69 - 275	300	149	2P90	111-783	111-783-B
3/4" (DN 20)	Polypropylene	10 - 150	0.7 - 10.3	195	90	3P	111-541	111-541-B
StdFlo	PVDF	10 - 150	0.7 - 10.3	300	149	3P	111-543	111-543-B
	316 SST	10 - 150	0.7 - 10.3	300	149	3P	111-546	111-546-B
	Hastelloy C	10 - 150	0.7 - 10.3	300	149	2P180	111-550	111-550-B
	316 SST	50 - 350	3.5 - 24	300	149	2P180	111-547	111-547-B
3/4" (DN 20)	Polypropylene	10 - 150	0.7 - 10.3	195	90	2P180	111-641	111-641-B
HiFlo	PVDF	10 - 150	0.7 - 10.3	300	149	2P180	111-643	111-643-B
	316 SST	10 - 150	0.7 - 10.3	300	149	2P180	111-646	111-646-B
	Hastelloy C	10 - 150	0.7 - 10.3	300	149	2P180	111-650	111-650-B
3/4" (DN 20)	316 SST	350 - 2500	24 - 172	300	149	2P90	111-746	111-746-B
High Pressure	Hastelloy C	350 - 2500	24 - 172	300	149	2P90	111-750	111-750-B
1" (DN 25)	Polypropylene	10 - 150	0.7 - 10.3	195	90	3P	111-561	111-561-B
StdFlo	PVDF	10 - 150	0.7 - 10.3	300	149	3P	111-563	111-563-B
	316 SST	10 - 150	0.7 - 10.3	300	149	3P	111-566	111-566-B
	Hastelloy C	10 - 150	0.7 - 10.3	300	149	2P180	111-570	111-570-B
	316 SST	50 - 350	3.5 - 24	300	149	3P	111-567	111-567-B
	Hastelloy C	50 - 350	3.5 - 24	300	149	2P180	111-571	111-571-B
1" (DN 25)	Polypropylene	10 - 150	0.7 - 10.3	195	90	2P180	111-661	111-661-B
HiFlo	PVDF	10 - 150	0.7 - 10.3	300	149	2P180	111-663	111-663-B
	316 SST	10 - 150	0.7 - 10.3	300	149	2P180	111-666	111-666-B
	Hastelloy C	10 - 150	0.7 - 10.3	300	149	2P180	111-670	111-670-B
1" (DN 25)	316 SST	350 - 2500	24 - 172	300	149	2P90	111-766	111-766-B
High Pressure	Hastelloy C	350 - 2500	24 - 172	300	149	2P90	111-770	111-770-B
2" (DN 50)	Polypropylene	10 - 150	0.7 - 10.3	195	90	2P90	111-581	111-581-B
StdFlo	PVDF	10 - 150	0.7 - 10.3	300	149	2P180	111-583	111-583-B
	316 SST	10 - 150	0.7 - 10.3	300	149	2P180	111-586	111-586-B
	Hastelloy C	10 - 150	0.7 - 10.3	300	149	2P180	111-590	111-590-B
	316 SST	50 - 350	3.5 - 24	300	149	2P180	111-587	111-587-B
	Hastelloy C	50 - 350	3.5 - 24	300	149	2P180	111-591	111-591-B

\* Diaphragm material is PTFE on all models. Other materials available on request.

# Pulsation Dampeners

Pulsation dampeners protect your pumping system and its components by removing virtually all hydraulic shock and vibration resulting from the reciprocating stroking action of a positive displacement pump.

Available in a variety of housing construction and bladder materials to cover different applications, pulsation dampeners are selected based on the size of the dampener (in cubic inches) needed to match your Hydra-Cell Metering Solutions pump model and discharge pulsation.

Since Hydra-Cell multiple-diaphragm model pumps provide smooth, linear, virtually pulse-free flow, pulsation dampeners are optional, except for the single-diaphragm P100 models, for which they are recommended.



## Selection Process

### Determine application

- Discharge pulsation <1000 psi or >1000 psi (<69 bar or >69 bar)
- Inlet stabilization:
  - For flooded suction, use “Chargeable.”
  - For suction lift, use “J Style.”

### Select dampener size (cu. in. volume)

Based on the Hydra-Cell Metering Solutions pump model and application, select the appropriate cubic inch size from the chart at right.

### Select dampener model

Use the appropriate dampener size chart on pages 66 to 68 to select the specific model with the desired housing materials, bladder material, and pressure and temperature performance. (Consult factory for special order units with other construction materials and temperature limits.)

Air Control Pump Model	Application			
	Discharge Pulsation		Inlet Stabilization	
	Chargeable <1000 psi <69 bar	Chargeable >1000 psi >69 bar	Chargeable Flooded Suction	J-Style Suction Lift
<b>MT8</b>	4 or 8 cu. in.	8 or 12 cu. in.	N/A	N/A
<b>P100 (F20)</b>	4 cu. in.	8 or 12 cu. in.	10 cu. in.	10 cu. in.
<b>P200 (M03)</b>	4 cu. in.	8 or 12 cu. in.	10 cu. in.	10 cu. in.
<b>P300 (D04)</b>	4 cu. in.	8 or 12 cu. in.	10 cu. in.	10 cu. in.
<b>P400 (D10)</b>	4 cu. in.	8 or 12 cu. in.	10 cu. in.	10 cu. in.
<b>P500 (D15/D17)</b>	4 cu. in.	8 or 12 cu. in.	10 cu. in.	10 cu. in.
<b>P600 (H25)</b>	36 cu. in.	N/A	36 cu. in.	85 cu. in.

#### Notes:

These are minimum size recommendations; a larger size can always be used. Pump Models in parentheses are for corresponding Bare Shaft Pumps shown on page 51.

## Bladder Options

Bladder Material	Application Recommendations
Buna-N	Good flex life; use with petroleum, solvents, and oil-based fluids
Neoprene	Good abrasion resistance and flex; use with moderate chemicals
EPDM	Good for extreme cold; good chemical resistance with ketones, caustics
FKM	Good for hot and aggressive fluids; use with aromatics, solvents, acids, and oils
PTFE	Bellows design, excellent flex life; use with highly aggressive fluids

#### 4 Cubic Inch Dampeners: Inlet 1/2" (female) Standard Models

Wetted	Bladder	Volume (Inch <sup>3</sup> )	Maximum Pressure		Part Number	
			psi	bar	NPT Ports	BSPT Ports
SST	Buna-N	4	1000	69	110-060	110-060-B
SST	Neoprene	4	1000	69	110-062	110-062-B
SST	EPDM	4	1000	69	110-063	110-063-B
SST	FKM	4	1000	69	110-065	110-065-B
SST	PTFE	4	600	41.4	110-068	110-068-B
Hastelloy C	Buna-N	4	1000	69	110-090	110-090-B
Hastelloy C	Neoprene	4	1000	69	110-092	110-092-B
Hastelloy C	EPDM	4	1000	69	110-093	110-093-B
Hastelloy C	FKM	4	1000	69	110-095	110-095-B
Hastelloy C	PTFE	4	600	41.4	110-098	110-098-B
Polypropylene	Buna-N	4	150	10.3	110-999	110-999-B
Polypropylene	Neoprene	4	150	10.3	110-101	110-101-B
Polypropylene	EPDM	4	150	10.3	110-104	110-104-B
Polypropylene	FKM	4	150	10.3	110-106	110-106-B
Polypropylene	PTFE	4	150	10.3	110-109	110-109-B
PVDF	Buna-N	4	150	10.3	110-020	110-020-B
PVDF	Neoprene	4	150	10.3	110-022	110-022-B
PVDF	EPDM	4	150	10.3	110-023	110-023-B
PVDF	FKM	4	150	10.3	110-026	110-026-B
PVDF	PTFE	4	150	10.3	110-028	110-028-B

#### 10 Cubic Inch Dampeners: Inlet 1/2" (female) Standard Models

Wetted	Bladder	Volume (Inch <sup>3</sup> )	Maximum Pressure		Part Number	
			psi	bar	NPT Ports	BSPT Ports
SST	Buna-N	10	1000	69	110-260	110-260-B
SST	Neoprene	10	1000	69	110-262	110-262-B
SST	EPDM	10	1000	69	110-263	110-263-B
SST	FKM	10	1000	69	110-265	110-265-B
SST	PTFE	10	150	10.3	110-268	110-268-B
Hastelloy C	Buna-N	10	1000	69	110-290	110-290-B
Hastelloy C	Neoprene	10	1000	69	110-292	110-292-B
Hastelloy C	EPDM	10	1000	69	110-293	110-293-B
Hastelloy C	FKM	10	1000	69	110-295	110-295-B
Hastelloy C	PTFE	10	150	10.3	110-298	110-298-B
Polypropylene	Buna-N	10	150	10.3	110-100	110-100-B
Polypropylene	Neoprene	10	150	10.3	110-232	110-232-B
Polypropylene	EPDM	10	150	10.3	110-233	110-233-B
Polypropylene	FKM	10	150	10.3	110-105	110-105-B
Polypropylene	PTFE	10	150	10.3	110-108	110-108-B
PVDF	Buna-N	10	150	10.3	110-220	110-220-B
PVDF	Neoprene	10	150	10.3	110-222	110-222-B
PVDF	EPDM	10	150	10.3	110-223	110-223-B
PVDF	FKM	10	150	10.3	110-225	110-225-B
PVDF	PTFE	10	150	10.3	110-228	110-228-B

### 36 Cubic Inch Dampeners: Inlet 1/2" (female) Standard Models

Wetted	Bladder	Volume (Inch <sup>3</sup> )	Maximum Pressure		Part Number	
			psi	bar	NPT Ports	BSPT Ports
SST	Buna-N	36	1000	69	110-660	110-660-B
SST	Neoprene	36	1000	69	110-662	110-662-B
SST	EPDM	36	1000	69	110-663	110-663-B
SST	FKM	36	1000	69	110-665	110-665-B
SST	PTFE	36	600	41.4	110-668	110-668-B
CS	Buna-N	36	1000	69	110-640	110-640-B
CS	Neoprene	36	1000	69	110-642	110-642-B
CS	EPDM	36	1000	69	110-643	110-643-B
CS	FKM	36	1000	69	110-645	110-645-B
CS	PTFE	36	600	41.4	110-648	110-648-B
Hastelloy C	Buna-N	36	1000	69	110-690	110-690-B
Hastelloy C	Neoprene	36	1000	69	110-692	110-692-B
Hastelloy C	EPDM	36	1000	69	110-693	110-693-B
Hastelloy C	FKM	36	1000	69	110-695	110-695-B
Hastelloy C	PTFE	36	600	41.4	110-698	110-698-B
Polypropylene	Buna-N	36	150	10.3	110-600	110-600-B
Polypropylene	Neoprene	36	150	10.3	110-602	110-602-B
Polypropylene	EPDM	36	150	10.3	110-603	110-603-B
Polypropylene	FKM	36	150	10.3	110-605	110-605-B
Polypropylene	PTFE	36	150	10.3	110-608	110-608-B
PVDF	Buna-N	36	150	10.3	110-620	110-620-B
PVDF	Neoprene	36	150	10.3	110-622	110-622-B
PVDF	EPDM	36	150	10.3	110-623	110-623-B
PVDF	FKM	36	150	10.3	110-625	110-625-B
PVDF	PTFE	36	150	10.3	110-628	110-628-B

### 85 Cubic Inch Dampeners: Inlet 1" (female) Standard Models

Wetted	Bladder	Volume (Inch <sup>3</sup> )	Maximum Pressure		Part Number	
			psi	bar	NPT Ports	BSPT Ports
SST	Buna-N	85	1000	69	110-760	110-760-B
SST	FKM	85	1000	69	110-765	110-765-B

### Pulsation Dampener Charging Kits

Part Number	Description
110-900	Pulsation Dampener Charging Kit to 999 psi (68.9 bar)
110-901	Pulsation Dampener Charging Kit 1000 to 5000 psi (69 to 345 bar)

### 8 Cubic Inch Dampeners: Inlet (female) High Pressure Models

Wetted	Bladder	Volume (Inch <sup>3</sup> )	Maximum Pressure		Part Number	
			psi	bar	NPT Ports	BSPT Ports
SST	PTFE	8	4000	(275)	110-049*	110-049-B*
SST	FKM	8	4000	(275)	110-050*	110-050-B*
SST	FKM	8	4000	(275)	110-051	110-051-B
SST	PTFE	8	4000	(275)	110-052	110-052-B

\*2-port, flow-through inlet design

### 12 Cubic Inch Dampeners: Inlet 1/2" (female) High Pressure Models

Wetted	Bladder	Volume (Inch <sup>3</sup> )	Maximum Pressure		Part Number	
			psi	bar	NPT Ports	BSPT Ports
SST	Buna-N	12	4000	(275)	110-370	110-370-B
SST	EPDM	12	4000	(275)	110-373	110-373-B
SST	FKM	12	4000	(275)	110-375	110-375-B
SST	PTFE	12	2000	(138)	110-368	110-368-B
SST	PTFE	12	4000	(275)	110-378	110-378-B
SST	FKM	12	4000	(275)	110-379*	110-379-B*
SST	PTFE	12	4000	(275)	110-380*	110-380-B*

\*2-port, flow-through inlet design

### 10 Cubic Inch Inlet Stabilizers with J-Style Control: Inlet 1/2" (female)

Wetted	Bladder	Volume (Inch <sup>3</sup> )	Maximum Pressure		Part Number	
			psi	bar	NPT Ports	BSPT Ports
CPVC	Buna-N	10	30	2	110-210-J	110-210-J-B
CPVC	Neoprene	10	30	2	110-212-J	110-212-J-B
CPVC	EPDM	10	30	2	110-213-J	110-213-J-B
CPVC	FKM	10	30	2	110-215-J	110-215-J-B
CPVC	PTFE	10	30	2	110-218-J	110-218-J-B

### 85 Cubic Inch Inlet Stabilizers with J-Style Control: Inlet 1" (female)

Wetted	Bladder	Volume (Inch <sup>3</sup> )	Maximum Pressure		Part Number	
			psi	bar	NPT Ports	BSPT Ports
PVC	Buna-N	85	30	2	110-710-J	110-710-J-B
PVC	Neoprene	85	30	2	110-712-J	110-712-J-B
PVC	EPDM	85	30	2	110-713-J	110-713-J-B
PVC	FKM	85	30	2	110-715-J	110-715-J-B
PVC	PTFE	85	30	2	110-718-J	110-718-J-B

# Other Services and Support

## Demonstration (Cutaway) Units

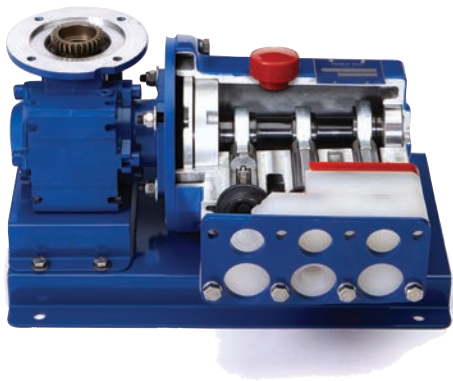

Description	Part Number
P200 Cutaway Demo with Rolling Carry Case	CUTAWAY-P200WCASE
P200 Cutaway Demo without Case	CUTAWAY-P200
Cutaway Demo Rolling Case Only	CUTAWAY-CASE

## Testing

Part Number	Description	Notes
TEST-STDPROD	Standard Production Tests	Rated Flow, Rated Pressure, & Steady State Accuracy
TEST-STDPRODWIT	Witnessed Standard Production Tests	Rated Flow, Rated Pressure, & Steady State Accuracy
TEST-HYDRO	Hydrostatic Test & Certificate	Includes Standard Production Tests
TEST-HYDROWIT	Witnessed Hydrostatic Test & Certificate	Includes Standard Production Tests
TEST-STDLIN	API 675 Linearity Test (5-point curve)	Includes Standard Production Tests
TEST-STDLINWIT	Witnessed API 675 Linearity Test (5-point curve)	Includes Standard Production Tests
TEST-STDLINREP	API 675 Repeatability Test (10-point curve)	Includes Standard Production Tests & API 675 Linearity Test
TEST-STDLINREPWIT	Witnessed API 675 Repeatability Test (10-point curve)	Includes Standard Production Tests & API 675 Linearity Test
TEST-STDHYDAPI	API 675 Test Package	Standard Production Tests, Linearity, Repeatability, & Hydrostatic
TEST-STDHYDAPIWIT	Witnessed API 675 Test Package	Standard Production Tests, Linearity, Repeatability, & Hydrostatic

## System Components

If needed, we can also deliver your Hydra-Cell Metering Solutions pumping system with all necessary strainers, suction accumulators, gauges, and other components.

## Priming Kits and Plugs

A vacuum priming kit is available for use after diaphragm replacement, and PVC priming plugs are used for priming the hydraulic cells in Hydra-Cell pumps equipped with patented Kel-Cell Diaphragm Position Control technology (models P400 and P600).

## Replacement Parts Kits and Tool Kits

Replacement Parts Kits are available for each P Series metering pump model, MT8 pumps, and Hydra-Cell bare shaft pumps for metering. Complete tool kits are also available customized to the specific pump model.

## Factory Services

OEM paint and nameplate customization, drawing packages, and other special services are available.

# Hydra-Cell® Glossary of Terms

**Absolute Pressure (PSIA):** The total force per unit area exerted by a fluid. It is the sum of Atmospheric Pressure and Gauge Pressure.

**Accuracy:** The degree of precision, usually expressed in terms of error, as a percentage of the specified value, or as a percentage of a range. (See separate definition for Steady-state Accuracy, per API 675 Standard, on the following page.)

**API 674 Standard:** This standard covers the minimum requirements for reciprocating positive displacement pumps for service in the petroleum, chemical, and gas industries. Both direct-acting and power-frame types are included. There are no test requirements defined within API 674 Standard for Steady-state Accuracy, Flow Repeatability, or Linearity.

**API 675 Standard:** This standard covers the minimum requirements for controlled volume positive displacement pumps for service in the petroleum, chemical, and gas industries. Both packed-plunger and diaphragm types are included. Diaphragm pumps that use direct mechanical actuation are excluded. Hydra-Cell pumps meet and exceed the performance test requirements of API 675 Standard for Steady-state Accuracy, Flow Repeatability, and Linearity (as defined in section 4.3.3); however, they do not meet all design requirements defined in section 2 of the standard.

## Atmospheric Pressure:

The force exerted on a unit area by the weight of the atmosphere; the higher the elevation above sea level, the lower the atmospheric pressure,  $P_{atm}$ . (See graph on right.)

**Cavitation:** Process in which small bubbles are formed and implode violently; occurs instantaneously when  $NPSH_a < NPSH_r$ .

**Fluids:** Include liquids, gases, and mixtures of liquids, solids and gases. In this catalog, the terms fluid and liquid are both used to mean a pure liquid or a liquid mixed with gases or solids that act essentially like a liquid in pumping applications.

**Fluid Slip:** Commonly used to describe the migration of liquid around the internal moving parts of a pump. It is the volumetric difference between physical component displacement and liquid throughput of a pump system.

**Fluid Slip Loss:** Refers to the liquid that passes through the clearance space, ( $\sim .00005''$ ) between the piston and the cylinder wall. The clearance between the piston and cylinder wall must be optimized for the liquid being pumped in order to minimize the loss due to fluid slip.

**Head:** A measure of pressure expressed in feet of head for centrifugal pumps; indicates the height of a column of water being moved by the pump (without friction losses).

**Metering Linearity:** The degree to which performance or response approaches the condition of being linear; the maximum deviation from the ideal straight line that can be drawn through plotted calibration test points describing how flow varies with capacity setting. It is expressed as percent ( $\pm$ ) of the Rated Capacity of the pump. API 675 Standard stipulates that Linearity must remain within  $\pm 3\%$ . Linearity of  $\pm 3\%$  or better can be achieved with Hydra-Cell pumps; it is a function of rated speed, Turndown Ratio, and system operating temperature and pressure ranges.

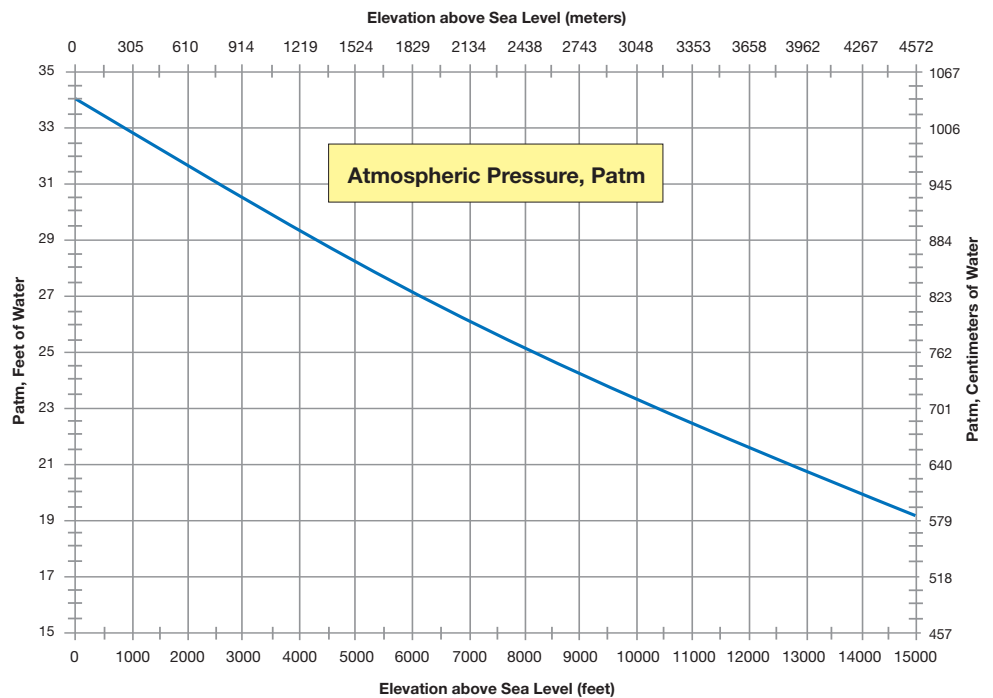

# Hydra-Cell® Glossary of Terms

**Metering Repeatability:** Describes the reproducibility of pump flow rate under a given set of conditions when the capacity setting is varied and then returned to the set point being tested; expressed as a percent ( $\pm$ ) of rated capacity. API 675 Standard stipulates that repeatability must remain within  $\pm 3\%$ . Flow Repeatability of  $\pm 3\%$  or better can be achieved with Hydra-Cell pumps; it is a function of rated speed, turndown ratio, and system operating temperature and pressure ranges.

**Metering Steady-state Accuracy:** Flow variation expressed as a percentage of mean delivered flow under fixed system conditions; applies over the Turndown Ratio. API 675 Standard stipulates that Steady-state Accuracy must remain within  $\pm 1\%$ . Steady-state Accuracy of  $\pm 1\%$  for Hydra-Cell P Series metering pumps reflects continuous run, injection-mode metering.

See pages 14 and 15 for graphs depicting Hydra-Cell performance pertaining to API 675 Standard for Accuracy, Linearity, and Repeatability.

## **Net Positive Suction Head Available (NPSHa):**

The total suction head (in feet or meters absolute) present at the pump suction connection, less the vapor pressure of the pumped liquid (in feet or meters absolute). NPSHa is a function of the system in which the pump operates everything on the suction side of the pump up to the suction port. The formula below is commonly used to determine system NPSHa.

$$\text{NPSHa} = P_t + H_z - H_f - H_a - P_{vp}$$

$P_t$ : Atmospheric pressure

$H_z$ : Vertical distance from surface liquid to pump centerline (if liquid is below pump centerline, then  $H_z$  is negative)

$H_f$ : Friction loss in suction pumping

$H_a$ : Acceleration head at pump suction

$P_{vp}$ : Absolute vapor pressure of liquid at pumping temperature

*Note: It is important to correct for the specific gravity of the liquid and to convert all terms to units of “feet absolute” or “meters absolute” when using this formula.*

**Net Positive Suction Head Required (NPSHr):** The positive pressure (in feet absolute) required at the pump suction port to overcome pressure losses that occur as the fluid travels from the suction port to the point(s) inside the pump where the pressure starts to increase. NPSHr is a function of the pump

design, size (capacity), and operating speed. It is measured at the suction port of the pump and typically provided by the pump manufacturer in the form of a curve or set of curves.

*Note: Testing in water is standard practice; therefore, NPSHr data is generally provided in units of “feet of water.” This must be taken into consideration and converted to “feet of pumped liquid” when comparing to the calculated value of NPSHa.*

**Prime:** Charge of liquid required to begin pumping action when the liquid source is lower than the pump; held in pump by a foot valve on the intake line or by a valve or chamber within the pump.

**Rated Capacity:** The quantity of fluid actually delivered per unit of time at the maximum operating speed. This quantity can be expressed in units of volume or mass; it includes liquid and any dissolved or entrained gases or solids, and is based on suction conditions.

**Specific Gravity:** The ratio of the weight of a given volume of liquid to pure water. Pumping heavy liquids (specific gravity greater than 1.0) will require more drive horsepower.

**Static Discharge Head:** Maximum vertical distance (in feet) from pump to point of discharge with no flow.

**Total Head:** Sum of discharge head, suction lift, and friction loss.

**Turndown Ratio:** The Rated Capacity divided by the minimum capacity that can be obtained while maintaining specified Steady-state Accuracy, Flow Repeatability, and Linearity. A 10:1 Turndown Ratio capability is industry standard for metering applications. Use of sophisticated motor controls allows speed Turndown Ratios of 1000:1 and greater if required. The mechanical response of the metering pump over these extremely high Turndown Ratios may or may not meet API 675 Standard testing requirements.

**Viscosity:** The resistance of a fluid to flow when subjected to shear stress (the “thickness” of a liquid). Most liquids decrease in viscosity and flow more easily as they get warmer. Absolute viscosity is measured in centipoises. Kinematic viscosity includes the influence of the specific gravity of the fluid and is measured in centistokes.

# Other Wanner Engineering Pumps



[www.Hydra-Cell.com](http://www.Hydra-Cell.com)

## F/M/D/H & G Series Pumps

The original line of versatile, reliable Hydra-Cell Seal-less pumps. Maximum flow rates range from 1.0 to 65.7 gpm (3.8 to 248.7 l/min) depending on model. Maximum discharge pressure ratings range from 700 to 2500 psi (48 to 172 bar) for metallic pump heads and 250 to 350 psi (17 to 24 bar) for non-metallic pump heads.



## T & Q Series Pumps

Designed to meet applications requiring larger capacities. Hydra-Cell Seal-less Pumps in the T & Q Series offer various models with maximum flow rates from 26 to 157 gpm (98 to 595 l/min) and maximum discharge pressures from 1500 to 5000 psi (103 to 345 bar).



# Non-metallic ANSI Centrifugal Pumps

## STAN-COR

- Solid PVDF pump head for chemical compatibility and excellent abrasion resistance.
- Operates with a smooth, full-curve performance.
- Concentric casing design for better flow patterns than other centrifugal pumps - less turbulence, longer seal life, and reduced shaft deflection.
- Handles high operating temperatures.
- Compact design features including heavy-duty drive shaft, adjustable bearing supports, and large-capacity oil bath ensure low maintenance as well as durable performance for the toughest fluid applications.
- Back pull-out design for easy servicing.
- Handles solid sizes up to 9/16" maximum.



*Designed to handle difficult process fluids, Stan-Cor pumps offer total dynamic head to 350 feet and flow rate capacities to 700 gpm (2650 l/min).*

# Peristaltic Pumps that Isolate the Pumped Fluid

## VECTOR

- Dry pump cavity.
- Self-priming operation.
- Runs dry without damage to the pump.
- Complete isolation of the fluid being pumped from contact with mechanical parts for the fluid transport system.
- Heavy-duty roller bearings.
- Wide range of pump configurations and flow rates.
- No cups, packing, or dynamic seals to leak or replace or come in direct contact with the pumped fluid.
- Low maintenance.
- Reversible flow.

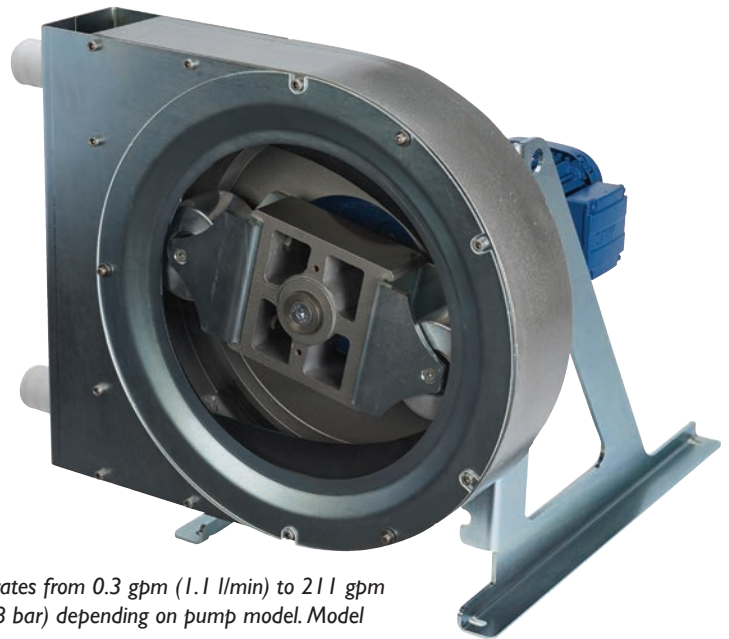

*Nine 2000 Series Vector pump models (2006 shown) offer maximum flow rates from 0.3 gpm (1.1 l/min) to 211 gpm (798.7 l/min) and discharge pressures from 30 psig (2.1 bar) to 116 psig (8 bar) depending on pump model. Model 3005 provides up to 9.2 gpm (34.8 l/min) at 200 psig (13.8 bar).*

*Seven 4000 Series Vector pump models offer maximum flow rates from 0.79 gpm to 154.1 gpm and discharge pressures of 110 psig or 218 psig depending on pump model.*



## Hydra-Cell® Limited Warranty

Wanner Engineering, Inc. (WEI) warrants that, for a period of one (1) year from the date of purchase, equipment supplied or manufactured by WEI shall be free of defects in materials and workmanship under normal use and service, and provided the equipment is installed, operated and maintained in accordance with instructions supplied by WEI.

Notwithstanding anything to the contrary, this limited warranty does not cover:

1. Normal wear and/or damage caused by or related to abrasion, corrosion, abuse, negligence, accident, faulty installation, or tampering which impairs normal operation of the equipment.
2. Electric motors (if applicable) not manufactured by WEI. The warranties, if any, on such equipment are assigned to the Purchaser by WEI (without recourse) at the time of purchase.
3. Transportation costs.

Purchaser's sole and exclusive remedy and WEI's sole liability, whether based upon warranty, contract or tort, including negligence, is limited to WEI's repair or replacement of the defective part, at WEI's sole option.

Any claim regarding breach of warranty must be received by WEI before the expiration of the warranty period and by written notice from Purchaser of such defect within thirty (30) days from the discovery thereof. WEI requires the return to a designated WEI location, of the defective part, transportation prepaid, to establish Purchaser's claim. No allowance will be made for repairs undertaken without WEI's written consent or approval.

**WEI's warranty obligations and Purchaser's remedies thereunder are solely and exclusively as stated herein.**

**There are no other warranties, whether oral, written, express, implied or statutory, including, but not limited to, implied warranties of merchantability and fitness for a particular purpose, warranties of non-infringement, warranties arising from course of dealing or usage of trade or any other matter.**

Any descriptions of the equipment drawings, specifications, and any samples, models, bulletins, or similar material used in connection with the sale of equipment are for the sole purpose of identifying the equipment and are not to be construed as an express warranty that the equipment will conform to such description. Any field advisory or installation support is advisory only.

Every form of liability for direct, special, incidental or consequential damages or loss is expressly excluded and denied. All liability of WEI shall terminate one (1) year from the date of purchase of the equipment.

# Hydra-Cell® Worldwide Sales and Service



Hydra-Cell pumps are sold and serviced worldwide by a comprehensive network of factory-trained pump distributors. As specialists in pump technologies, our distributor organizations offer you a vital local resource for technical expertise, product training, sales and service.

Hydra-Cell distributors are located in more than 70 countries worldwide. In North America specifically, there are more than 100 Hydra-Cell distributor locations to provide local availability for every major commercial, institutional, industrial, and municipal marketplace.

## World Headquarters & Manufacturing

★ Minneapolis, Minnesota, USA

## Business Units

- ☀ Wichita Falls, Texas, USA
- ☀ Hampshire, United Kingdom
- ☀ Kowloon, Hong Kong
- ☀ Shanghai, China
- ☀ São Paulo, Brazil

**MJ** MJ Systems, LLC  
HydraCell / CheckPoint Distributors  
TX - Off (281) 842-7600  
LA - Off (504) 264-7744  
**SYSTEMS** www.mjsusa.com • sales@mjsusa.com