

HUB-40EX HAZARDOUS AREA RATED FLOW SENSOR

Ideal for any industry or flow measurement application where an explosion-proof sensor is required, such as in chemical injection, hydraulic fracturing, or industrial paint spray booths.



FEATURES

- Choose from Hazardous area certification options including: cCSAus or ATEX/IECEX
- Square wave output signal has a duty cycle of approximately 50%.
- For use with all AW-Lake EX flow meters.



TECHNICAL SPECIFICATIONS

Supply Voltage
10-24 VDC

Supply Current

- 8 mA @ 12 VDC
- 12 mA @ 24 VDC
- 65 mA Maximum

Sensor/Monitor Frequency Output
Flow dependent, 0.5 Hz minimum

Output Amplitude

- $V_{HIGH} = V_{SUPPLY} - 0.7$ Volts
- $V_{LOW} = 0$ Volts

Duty Signal
50% ± 15%

Connections

- Terminal block, 1/2" female NPT conduit entrance
- Cable with 1/2" male NPT

Enclosure Rating
TYPE 4X

cCSAus Certification

- Class I, Div. I, Groups C, D
- Class II, Div. I, Groups E, F, G
- Class III

ATEX Certification
II 2 G, Ex d IIB+H₂ T5 Gb,
Ta = -40°C to +60°C

IECEX Certification
Ex d IIB+H₂ T5 Gb
Ta = -40°C to +60°C

Temperature Ratings

- -20 to 60°C (-4 to 140°F)
- 85°C (185°F) maximum fluid temperature

BENEFITS

Up and Running in Minutes

Easy thread-in installation. A quick setup procedure allows you to have the sensor working with just a few simple installation steps.

Flexible Mounting

Because of the integral swivel union, the HUB-40EX unit can be rotated 360° for easy wiring. Options available to fit any AW Gear Meter or Turbine Meter.

Weather-Proof Enclosure

NEMA 4X enclosure provides environmental protection from moisture and debris.

Built-In Protection

The signal outputs are protected by a self-resetting fuse with a 50 mA nominal trip point.

PART NUMBER:

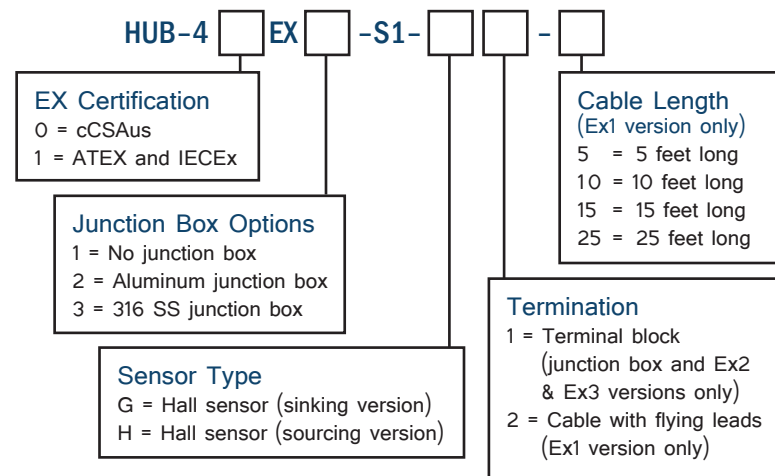

HUB-40EX HAZARDOUS AREA RATED FLOW SENSOR

Ideal for any industry or flow measurement application where an explosion-proof sensor is required, such as in chemical injection, hydraulic fracturing, or industrial paint spray booths.

HUB-40EX DIMMENSIONS (ALUMINUM HOUSING)

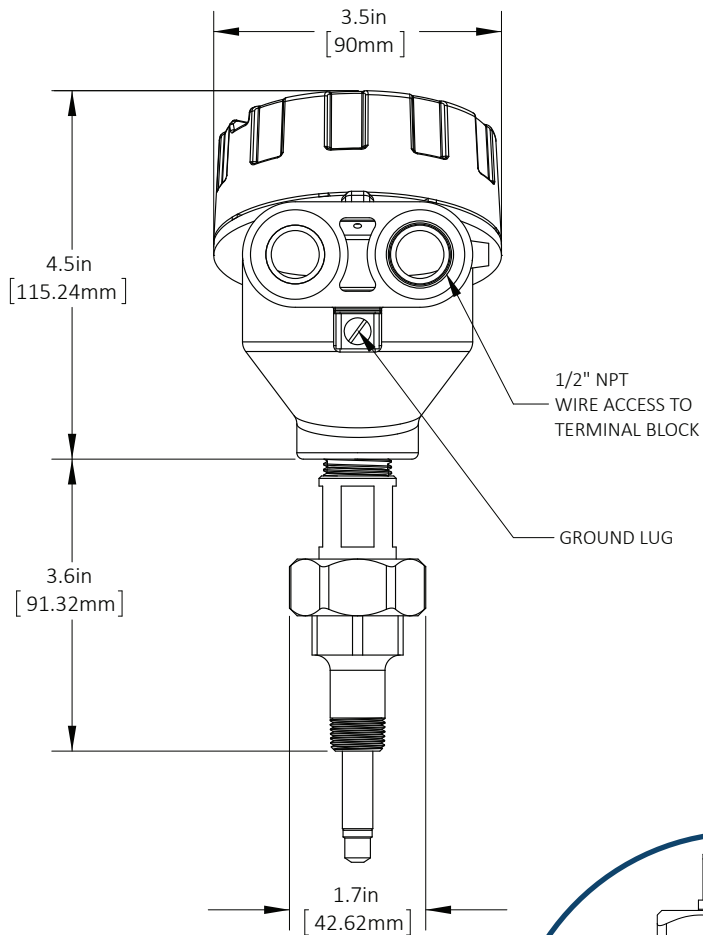

HUB-40EX DIMMENSIONS (STAINLESS STEEL HOUSING)

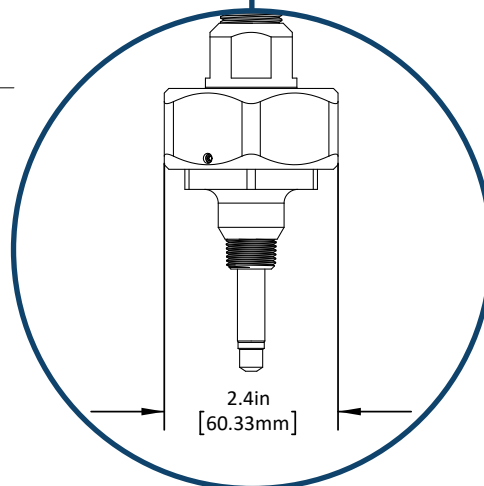
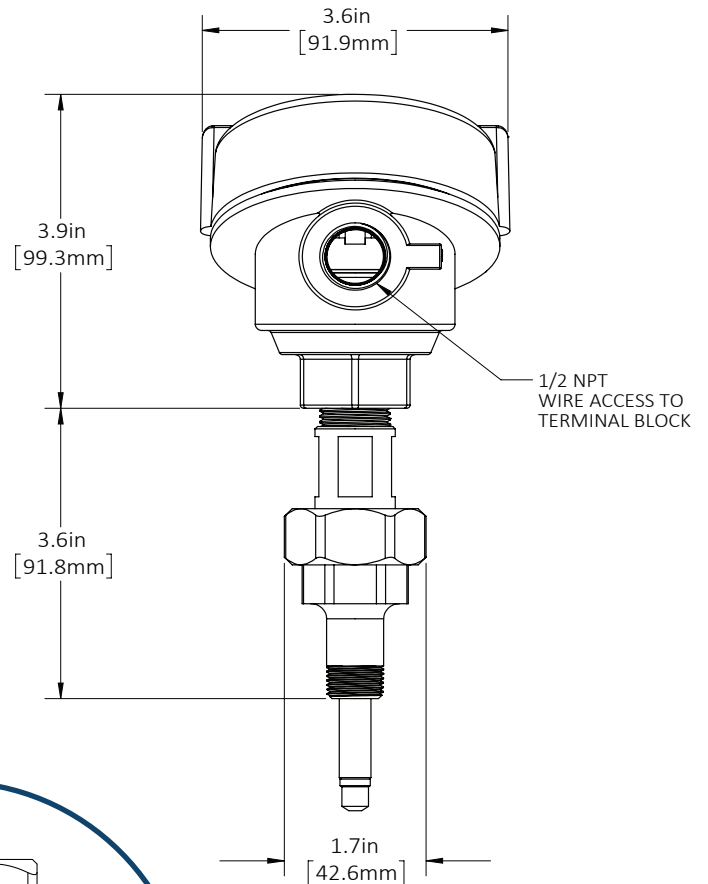

HUB-41EX SENSOR (ATEX & IECEX)

Products may be subject to change without notice - Contact factory for the most up-to-date product information.