

NOVAPLEX Vector

PROCESS DIAPHRAGM PUMPS



For more than 80 years, Bran+Luebbe - now SPX Flow Technology – has been providing customers with high quality metering, processing and analyzing equipment. As part of the global SPX Corporation, we are one of the world's most reputable manufacturers of metering and process pumps, process systems as well as analyzing technologies. Our engineers have comprehensive process and applications knowledge across a wide range of markets. This has resulted in product innovations and developments which harness the latest technology while meeting the highest quality standards.

Based in Charlotte, North Carolina, SPX Corporation (NYSE: SPW) is a global Fortune 500 multi-industry manufacturing leader with over \$5 billion in annual revenue, operations in more than 35 countries and over 15,000 employees. The company's highly-specialized, engineered products and technologies are concentrated in Flow Technology and energy infrastructure. Many of SPX's innovative solutions are playing a role in helping to meet rising global demand for electricity and processed foods and beverages, particularly in emerging markets. The company's products include food processing systems for the food and beverage industry, power transformers for utility companies, and cooling systems for power plants. For more information, please visit www.spx.com.

NOVAPLEX Vector

The Process Diaphragm Pump NOVAPLEX Vector combines a unique new gearbox design with well-proven diaphragm pump head technology and is ideally suited for applications in the oil & gas industry (onshore, offshore) as well in the chemical industry, offering a number of benefits, such as:

- Light weight
- Small footprint
- Easy maintenance due to reduced number of parts
- Less downtime
- Lower operation costs

PERFORMANCE DATA

- **Volume/capacity:** 2 - 70 m³/hr (9-308 gpm)
- **Pressure:** up to 400 bar (PTFE) (5800 psig)
up to 1000 bar (Metal) (14,500 psig)
- **Fluid temperature range:** -40° C to +150° C (-40° F to 300° F)
(special solutions upon request)
- **Ambient temperature range:** -40° C to +60° C (-40° F to 140° F)
(special solutions upon request)
- **Hazardous area:** up to Zone 1 IIC T4
(Zone 22 upon request)
- **Adjustable capacity (VFD)**

ADDITIONAL FEATURES

- Diaphragm position control for maximum operating security
- Safe dry-run capabilities
- High volumetric efficiency
- Hermetically sealed by two diaphragm layers
- Diaphragm condition monitoring
- NOVALINK_CSM 2 Diagnosis interface as standard

PERFORMANCE

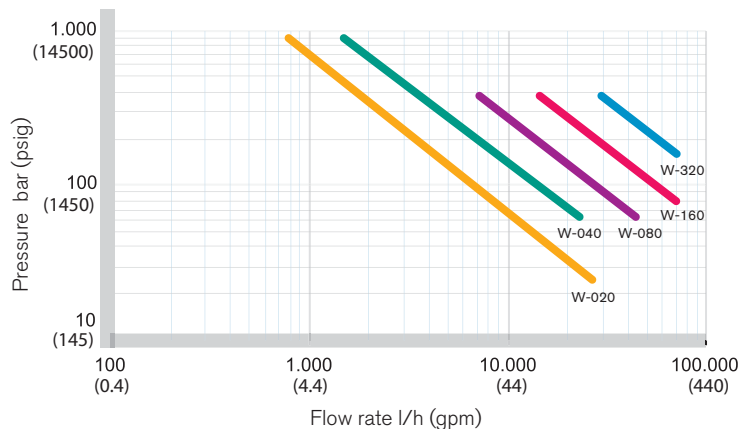

TYPICAL MARKETS WITH APPLICATIONS

Oil & Gas

- Methanol Injection
- Polymer Injection (Enhanced Oil Recovery)
- Hydrocarbon transfer
- and many more

Chemical Processing Industry

- Reactor Feed
- and many more

Mining

- Autoclave Feed

FLUIDS PUMPED

- Ammonia
- Liquefied CO₂
- Hydrocarbon Condensate
- Methanol, Glycol, Biocides
- LPG (Liquefied Petroleum Gas)
- Propionic Acid
- Raney Nickel suspensions
- Vinyl Chloride Monomer
- Vinyl Acetate Copolymer



COMPACT GEAR DESIGN

- Small footprint
- Reduced weight
- Reduced maintenance effort

ESTABLISHED PUMP HEAD TECHNOLOGY

- A pressure relief valve within the hydraulic system of the pump head protects not only the pump head but also the pump gear from overload due to excessive pressure
- Increased diaphragm life compared to non-positive control systems
- Diaphragm protection even under critical operating conditions
- Dry running capabilities
- Double-diaphragm pumps with diaphragm condition monitoring offer higher operation security than single diaphragm pump heads

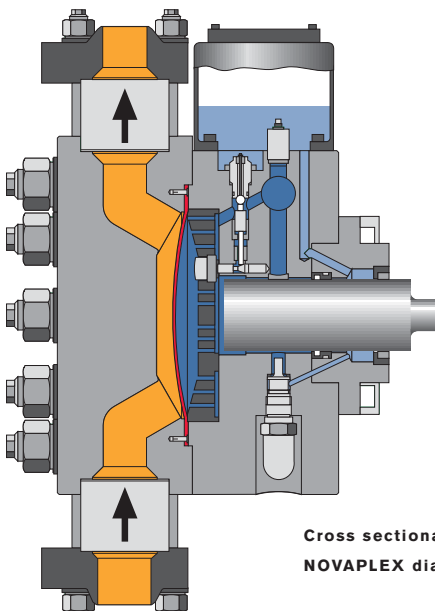

Cross sectional drawing of a
NOVAPLEX diaphragm pump head

SPX[>]FLOW



NOVAPLEX Classic



NOVAPLEX Integral

Alternatively to the NOVAPLEX Vector pumps the NOVAPLEX Classic with externally mounted gear reducer, enabling an extended number of pump heads and the NOVAPLEX Integral with integrated gear reducer for minimized foot print are available for special projects.

Global locations

USA

SPX GLOBAL HEADQUARTERS

13320 Ballantyne Corporate Place
Charlotte, NC 28277
United States of America
Phone: +1 704 752 4400

EMEA

SPX FLOW TECHNOLOGY

Werkstraße 4
D-22844 Norderstedt
Phone: +49 (0) 40 - 522 02 -0
Fax: +49 (0) 40 - 522 02 -444

SPX FLOW TECHNOLOGY

Ironstone Way
Brixworth, Northants, NN69UD
Phone: +44 (0) 1604 881751
Fax: +44 (0) 1604 880145

APAC

SPX FLOW TECHNOLOGY

25 International Business Park
#03-03/12, German Centre,
Singapore 609916
Phone: +65 6568 1568
Fax: +65 6265 9133
E-Mail: asia.pacific@spx.com

SPX FLOW TECHNOLOGY

611 Sugar Creek Road
Delavan, WI 53115
P: (800) 252-5200 or +1 (262) 728-1900
F: (262) 728-4904
E: branluebbe@spx.com • www.spx.com



MJ Systems, LLC
SPX Flow>Bran+Luebbe Representatives
TX - Off (281) 842-7600
LA - Off (504) 264-7744
www.mjsusa.com • sales@mjsusa.com

SPX reserves the right to incorporate our latest design and material changes without notice or obligation.

Design features, materials of construction and dimensional data, as described in this bulletin, are provided for your information only and should not be relied upon unless confirmed in writing. Please contact your local sales representative for product availability in your region. For more information visit www.spx.com.

The green ">" is a trademark of SPX Corporation, Inc.