

NOVADOS Metering Pumps

METERING PUMP WITH DOUBLE-ACTING DIAPHRAGM PUMP HEAD

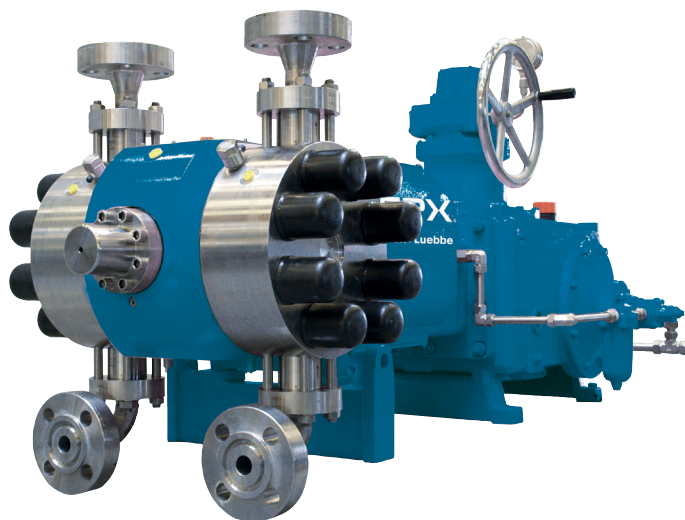

Part of SPX Corporation (NYSE: SPW), the Flow Technology segment designs, manufactures, installs and services highly engineered solutions used to process, blend, meter and transport fluids, in addition to air and gas filtration and dehydration. The segment supports the food and beverage, dairy, pharmaceutical, oil and gas, energy, and industrial markets worldwide.

Based in Charlotte, North Carolina, SPX Corporation (NYSE: SPW) is a global Fortune 500 multi-industry manufacturing leader with over \$5 billion in annual revenue, operations in more than 35 countries and over 15,000 employees. The company's highly-specialized, engineered products and technologies are concentrated in Flow Technology and energy infrastructure. Many of SPX's innovative solutions are playing a role in helping to meet rising global demand for electricity and processed foods and beverages, particularly in emerging markets. The company's products include food processing systems for the food and beverage industry, power transformers for utility companies, and cooling systems for power plants. For more information, please visit www.spx.com.

For more than 75 years, Bran+Luebbe - now SPX Flow Technology – has been providing customers with high quality metering, processing and analysing equipment.

As part of the global SPX Corporation, we are one of the world's most reputable manufacturers of metering and process pumps, process systems as well as analyzing technologies. Our engineers have comprehensive process and applications knowledge across a wide range of markets. This has resulted in product innovations and developments which harness the latest technology whilst meeting the highest quality standards.

Direct comparison of a methanol pump

Product: Methanol
Required flow: 2.500 l/h
Operating pressure: 335 bar

Pump with **double-acting** diaphragm pump head
 2.470 kg - 3,66 m²

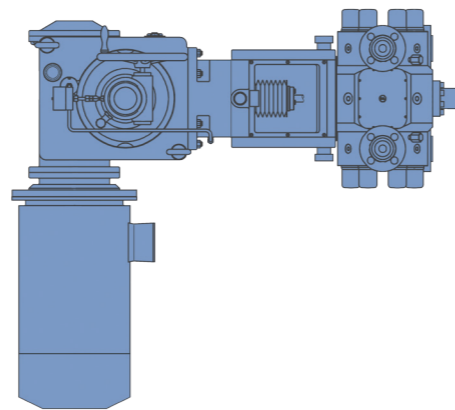
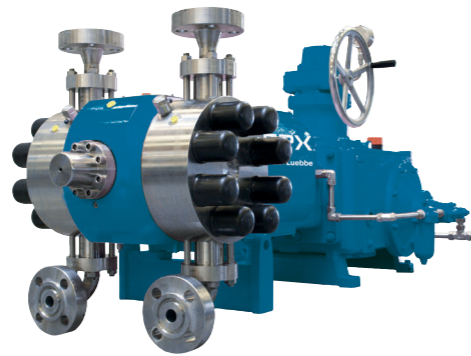

Pump with two conventional **single-acting** diaphragm pump head
 3.170 kg - 4,41 m²

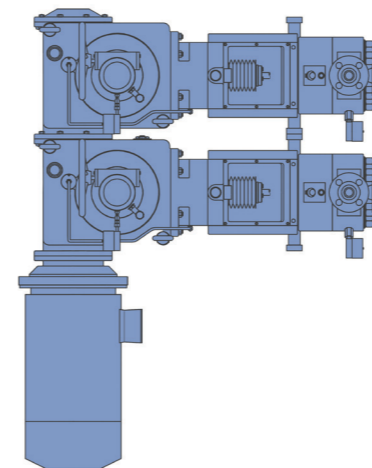

Advantages

- Smaller footprint
- Lower weight
- Low maintenance costs

Applications

Examples of liquids

- Liquid ammonia
- Hydrocarbons
- Latex emulsions
- Liquid carbon dioxide
- LPG
- Methanol
- Naphta
- Raney nickel suspensions
- Sulphuric acid
- Toluene
- Water



Markets served

- Oil & Gas
- Petrochemical industry
- Chemical industry



FLOW RATE TABLE (FOR SINGLE MODULE) ¹⁾

max. operating pressure bar	GEAR SIZE			
	H4	H5	H6	B
	max. flow rate l/h			
500	-	-	-	2920
400	-	-	1250	-
360	-	-	-	4220
315	-	-	-	4910
250	-	-	1730	5960
160	-	-	2930	9350
130	-	-	3540	11730
100	-	2930	4550	15520
80	-	-	5420	-
63	-	-	7160	-
40	-	7160	11350	-
10	11350	-	-	-

¹⁾ The table shows an excerpt of all possibilities and serves as an initial guideline. Pumps will be sized for the specific requirements.

- Flow rates at 100% volumetric efficiency. Please allow for transmission losses
- Stroke frequency 200 min⁻¹ for H4 - H6 and 212 min⁻¹ for B
- Metering accuracy: as good as ±0.5 %
- Different stroke frequencies available

SPXFLOW

METERING PUMPS

THE PRODUCT RANGE: MORE EXAMPLES OF BRAN+LUEBBE PRODUCTS WITH HIGH QUALITY STANDARD, INNOVATION AND KNOW-HOW.



Metering pumps
for universal applications
in the low to medium
requirement range
ProCam
ProCam Smart
ProCam Hygienic



Process pumps
for large flow rates and
high operating pressures
NOVAPLEX
MEGANIZER
High pressure homogenizer



Dynamic in-line mixer
for gentle but intensive
mixing
PENTAX
PENTAX Hygienic



Process systems
as a complete solution for
increased productivity and
quality
AutoBlend
Metering and mixing systems



Oil & Gas systems
to aid oil & gas recovery
onshore and offshore
Solar Panel Packages
Chemical Injection Systems
Flow Control Device Panels



On-line analyzers
for use in water
and effluent treatment
PowerMon
PowerMon S
PowerMon Compact

Global locations

EMEA

SPX FLOW TECHNOLOGY

Werkstraße 4
D-22844 Norderstedt
Phone: +49 (0) 40 - 522 02 -0
Fax: +49 (0) 40 - 522 02 -444
E-Mail: branluebbe@spx.com

SPX FLOW TECHNOLOGY

Ironstone Way
Brixworth, Northants, NN6 9UD
Phone: +44 (0) 1604 880751
Fax: +44 (0) 1604 880145
E-Mail: ft.brixworth.sales@spx.com

AMERICAS

SPX FLOW TECHNOLOGY

611 Sugar Creek Road
Delavan, WI 53115 USA
Phone: +1 (800) 252-5200 or
+1 (262) 728-1900
Fax: +1 (262) 728-4904
E-Mail: branluebbe.americas@spx.com

APAC

SPX FLOW TECHNOLOGY

25 International Business Park
#03-03/12, German Centre,
Singapore 609916
Phone: +65 6568 1568
Fax: +65 6265 9133
E-Mail: asia.pacific@spx.com

SPX FLOW TECHNOLOGY NORDERSTEDT GMBH

Werkstraße 4
D-22844 Norderstedt
Phone: +49 (0) 40 - 522 02 -0
Fax: +49 (0) 40 - 522 02 -444
E-Mail: branluebbe@spx.com



MJ Systems, LLC
SPX Flow > Bran+Luebbe Representatives
TX - Off (281) 842-7600
LA - Off (504) 504-7744
www.mjsusa.com • sales@mjsusa.com

SPX reserves the right to incorporate our latest design and material changes without notice or obligation.

Design features, materials of construction and dimensional data, as described in this bulletin, are provided for your information only and should not be relied upon unless confirmed in writing. Please contact your local sales representative for product availability in your region. For more information visit www.spx.com.

"The green ">" is a trademark of SPX Corporation, Inc."