

➤ Waukesha Cherry-Burrell®



UNIVERSAL INDUSTRIAL SERIES

5000 Series

Rotary Positive Displacement ECP Pumps



MJ Systems, LLC - Representatives
SPX Flow>Waukesha Cherry-Burrell
TX - Off (281) 842-7600
LA - Off (504)-264-7744
www.mjsusa.com • sales@mjsusa.com



SPXFLOW®

LONG-LIFE ENGINEERING FEATURES. HIGH VOLUMETRIC EFFICIENCY, LOW SHEAR AND REDUCED OPERATIONAL AND MAINTENANCE COSTS.

Product Features and Benefits

- 316L stainless steel body & cover and 316 stainless steel shafts.
- Non-galling Waukesha "88" alloy rotors standard, permits running at tighter clearances and pumping a wide range of viscosities.
- Very low shear, product not damaged during pumping.
- Wide selection of commercial seals, packing, and triple lip seals including cartridge seals.
- Requires less horsepower than Progressing Cavity Pumps.
- Bidirectional flow.
- Upper or lower shaft positions.
- Pumps filled with most settled slurries will start without damaging pump or seals.
- Expanded fluid cavities can pump liquids with large solids without jamming or knocking rotors out of timing.
- Unique timing gear arrangement reduces troublesome maintenance issues, as experienced on conventional lobe pumps.
- No cross contamination of lubricating oil or grease into product zone, due to unique gear case design.
- Pumps are energy efficient, and when needed easily maintained, and repaired.
- Versatile 3-way mounting of gear case, including vertical alignment of ports.



Long-life Features

- 200 psi (13.8 bar) pressure capability.
- Heavy duty Cast Iron bearing frame.
- No internal rotor contact.
- Double tapered roller bearings on all models.
- Grease lubricated bearings for positive lubrication to all bearings over entire speed, temperature and pressure range.
- Body retaining screws for maintaining mechanical seal loading and body position during inspection.
- Steel-It Paint.
- Remanufacturing Program to extend life and reduce costs.
- Carbon cover bushings to minimize shaft deflection and wear.

Available Options

- High strength 17-4 PH shafts for severe duty applications.
- 300 lb & DIN flanges, and NPT port connections.
- Stainless steel bearing retainers.
- Bearing isolators protect bearings from contamination.
- Jacketed or internal by-pass relief valve covers.
- Waukesha (ISR) Integral Speed Reducers, eliminates coupling alignment and saves space.
- 316L SS rotors. Review with factory for when to apply
- External over-pressure relief valves for full flow relief
- Tru-Fit® integral gear to motor drive.
- Armoloy® coating for abrasive service.
- Optional port sizes on 5040 thru 5060 models.
- Side mount pedestals for vertical porting.
- Hot and front face rotor clearances, for high temperature fluids.
- Alloy 88 & Rulon cover bushings.
- Ceramic coated packing sleeves.

TYPICAL PRODUCT APPLICATIONS



SOLVENTS:

Acetone, Carbon "Tet",
Spirits, M.E.K. Turpentine



OIL & LUBRICANTS:

Crude Oil, Diesel #2 Oil,
Bunker Oil, Lubricant Oil,
Fuel Oils, Greases, Oil
Additives



OTHER:

Acids, Adhesives, Alkalies,
Animal Fats, Ammonium
Nitrate, Defoamers, Glue,
Latex, Lacquer, Melamine,
Paper Coatings, Polymers,
Polyvinyl Alcohol, Printing
Ink, Resins, Silicone
Emulsions, Soaps, Sludges,
Starches, Urea

OPTIONS

Installation Flexibility

- Bi-directional flow. Rotors, locked in place, rotate securely in either direction. No flow direction/shaft position specifications.
- Versatile 3-Way mounting of gearcase, including vertical alignment of ports.
- Upper or lower shaft position. Upper shaft position is standard.
- Side mount pedestals with left hand shaft position as standard. Right hand shaft position is optional.

Drive Options

- Standard is direct connected gear motor with coupling & SS guard mounted on base.
- WCB ISR Integral Speed Reducer Sizes 49, 79 and 239.
- Mechanical and Electronic Variable Speed Drives.
- Hydraulic Motor Drives.
- Close coupled Tru-Fit® gear motors mounted.

Bases

- Channel Steel with steel-it paint is standard.
- T B Woods Coupling with SS coupling Guard is standard.
- Fabricated Steel epoxy painted
- 304 SS unpolished flat plate
- Portable Base with rubber wheels

Tru-Fit Version

- No shaft alignment necessary. No coupling guard required.
- Reduces overall length of complete unit by an average of 20-25%
- NEMA or IEC frame motors available.
- ½ through 60 horsepower drive options available.

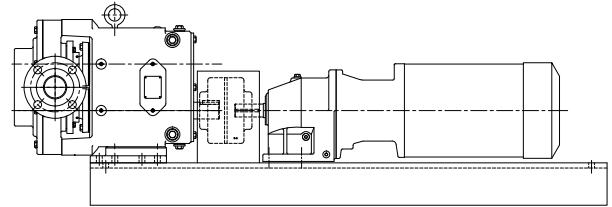

STANDARD CHANNEL STEEL BASE

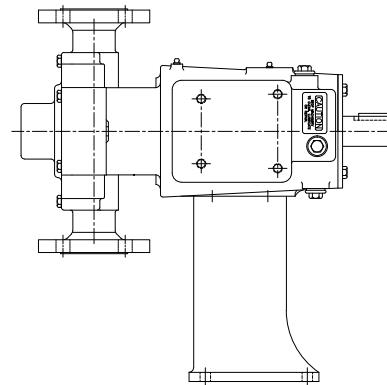

VERTICAL PORTED UNIT

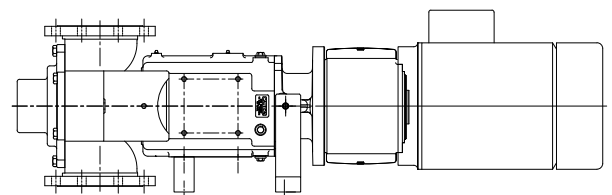

VERTICAL PORTED UNIT SHOWN
(STANDARD HORIZONTAL PORTS AVAILABLE)

TIME-TESTED WCB ROTARY PUMP; ECP OPERATING PRINCIPLE

Theory of Operation

In the WCB design, arc-shaped “pistons” (rotor wings) travel in annular shaped cylinders machined in the pump body; the resulting long sealing path reduces slippage and produces a smooth flow of product without destructive pulses or pressure peaks and without valves or complex parts.

For Low Viscosity Fluids

Rotors, made of exclusive Waukesha Alloy 88, can be run with close clearance to the 316 stainless steel fluid head, without galling or seizing should inadvertent pressure surges cause contact. The close clearances combined with the rotor geometry, which gives a long sealing path between the pump inlet and outlet, means low slip operation. As a result, you achieve: high volumetric efficiency and good flow control.

For High Viscosity Fluids

The large fluid cavities of the rotors plus the large, easy entry anti-cavitation ports, allow efficient pumping of high viscosity fluids, slurries or even liquids with large chunks or particles.

For Non-Lubricating and Abrasive Fluids

The unique WCB design has no bearings in the fluid being pumped, no sliding or rolling contact and no rotor-to-rotor contact. This produces **MAXIMUM SERVICE LIFE** even under severe operating conditions.

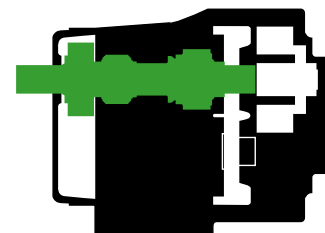
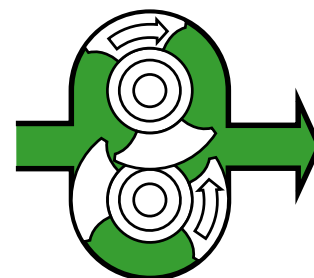
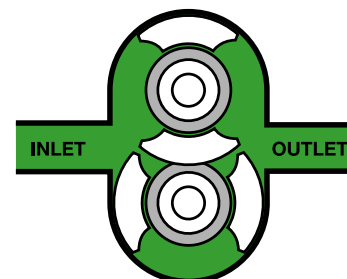
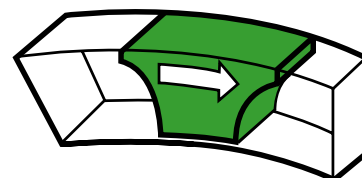

The Waukesha Cherry-Burrell Universal Industrial 5000 Series gives you . . .

High pressure capability: 200 psi/13.8 bar*.

Long service life: High capacity components for long trouble-free service.

Metal rotor: Waukesha "88" non-galling alloy, for close running clearance.

*For higher pressures and temperatures consult the factory.

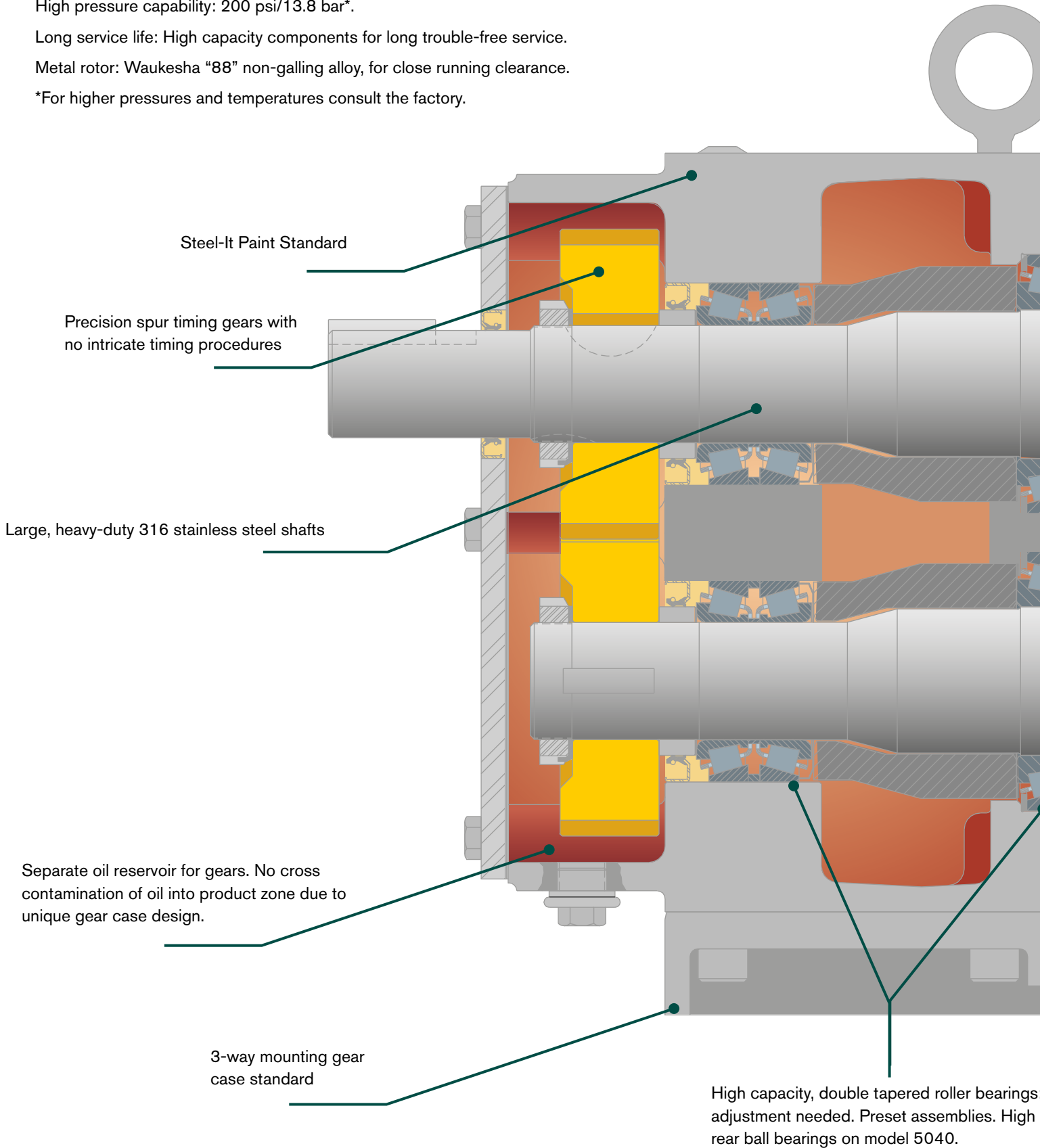

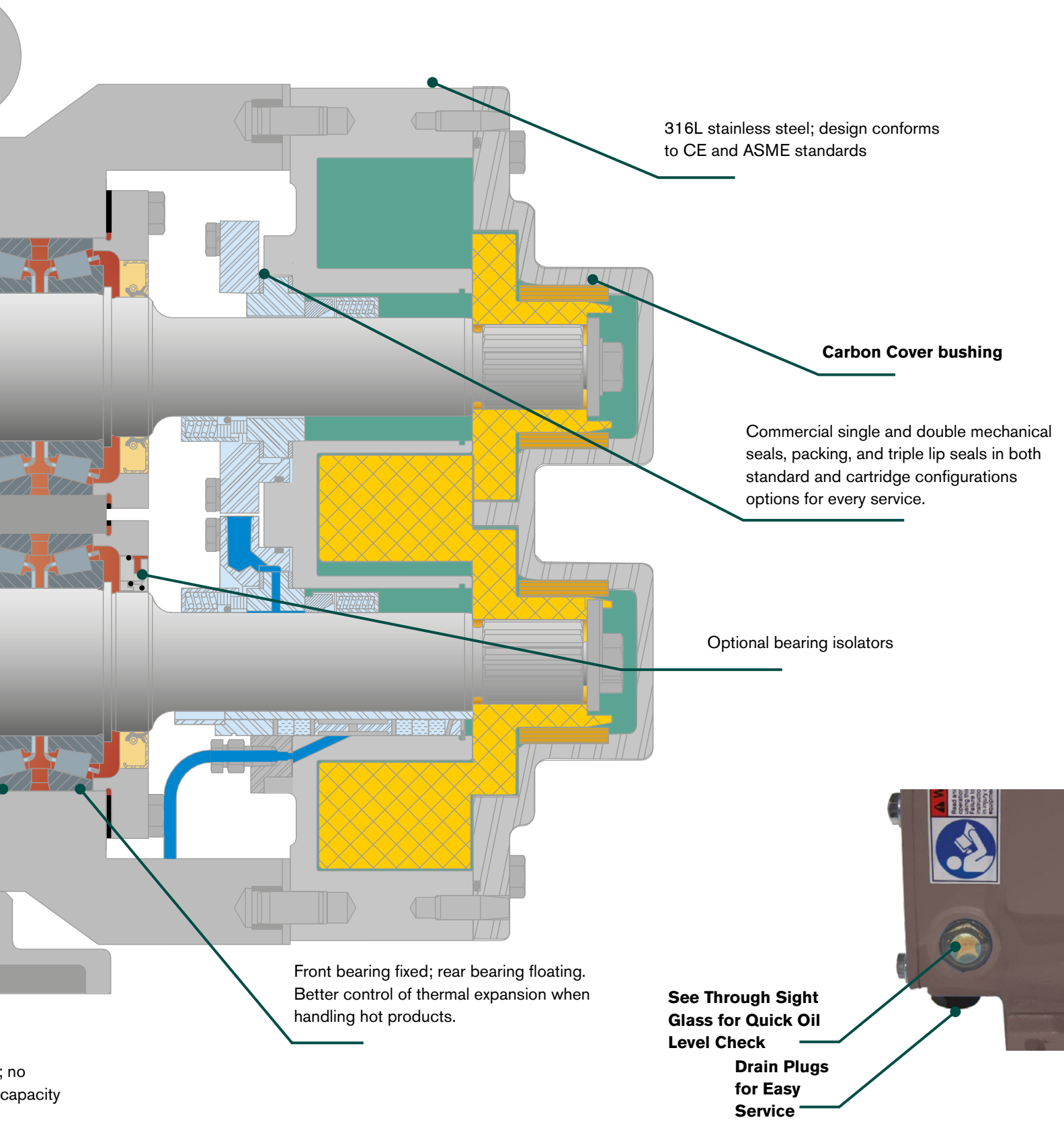

; no
capacity

SEAL OPTIONS

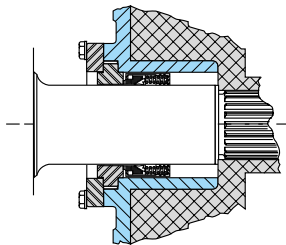

Single Inner Mechanical Seal

J. Crane Type 9 with carbon and ceramic seal faces standard. Narrow face seal with TC and SC seal faces as option. Consult factory.

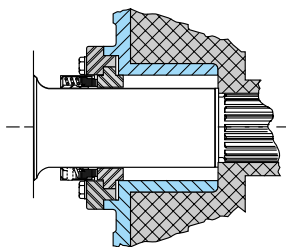

Single Outer Mechanical Seal

J. Crane Type 8B2 with carbon and ceramic seal faces standard.

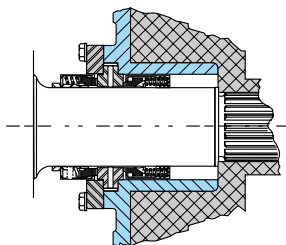

Double Mechanical Seal

Used with flushing fluid to cool, lubricate, flush away residue. Best arrangement for severe service. Combines above single inner and outer seals.

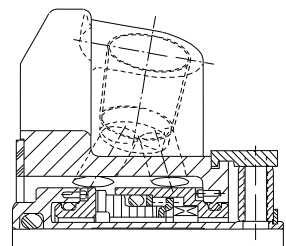

Cartridge Seals

Consult factory for availability. See instruction manual 95-03012 for stuffing box dimensions.

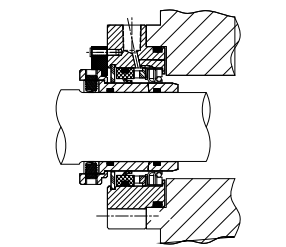

Triple Lip Seal

Available in Cartridge design. Consult factory.

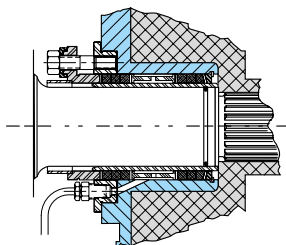

Packing

J. Crane Style 1335 TFE impregnated braided acrylic with stainless steel sleeve standard.

Elastomer choices for "O" rings: Buna-N, Fluoroelastomer (FKM), EPDM, Silicone, Perfluoroelastomer (FFKM), PTFE Encapsulated

Mechanical seal material options: Carbon, Ceramic, Silicon Carbide, Tungsten Carbide

DIMENSIONAL DATA

Universal 5000 Industrial Series

***NOTE:** CP3 is the maximum dimension for all vented and jacketed cover options. Dimensions are for guidance purposes only. Contact your SPX FLOW Representative if more detailed measurements are needed.

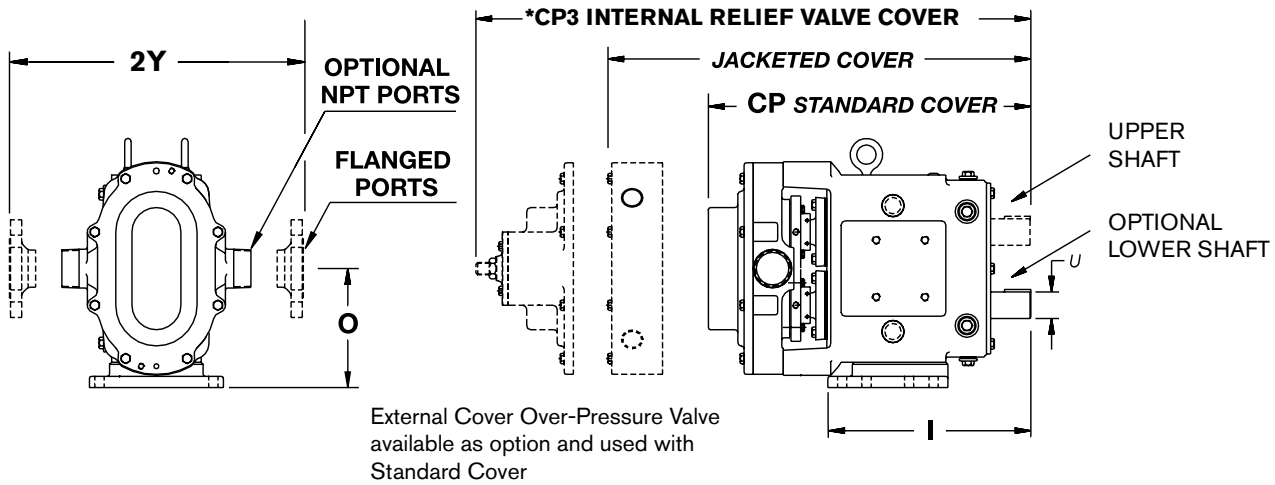

MODEL		CP	CP3*	I	O	PORT SIZE	U +.000 -.001	2Y	APPLICABLE WEIGHTS	
									LBS	KGS
5040	in	16.52	18.64	8.83	5.21	1 1/2"-11 1/2 NPT	1.25	11.91	100	45
	mm	419	473	224	132	--	31.75	303		
5050	in	19.83	23.08	12.49	7.31	2"-11 1/2 NPT	1.625	13.25	240	109
	mm	504	586	317	186	--	41.28	337		
5060	in	20.78	24.03	12.49	7.31	2 1/2"- 8 NPT	1.625	13.50	245	111
	mm	528	610	317	186	--	41.28	343		
5070	in	26.31	28.50	15.29	9.38	4"-150# FLANGE	2.00	14.75	475	215
	mm	668	724	388	238	--	50.80	375		
5080	in	30.17	34.05	17.80	10.38	6"-150# FLANGE	2.375	16.00	810	367
	mm	766	865	462	264	--	60.33	406		

MODEL	DISPLACEMENT PER REVOLUTION		NORMAL CAPACITY TO		INLET/OUTLET		OPTIONAL INLET/OUTLET		PRESSURE RANGE**		MAXIMUM RPM***	TEMP RANGE*
	GAL.	LITER	GPM	M ³ /HR	IN	MM	IN	MM	PSI	BAR		
5040	.060	0.227	36	8.2	1.5"	38	2"	51	200	13.8	600	Std. Rotors: -40°F (-40°C) to 200°F (93°F)
5050	.153	0.579	90	20.4	2"	51	2.5"	64	200	13.8	600	
5060	.254	0.961	150	34.1	2.5"	64	3"	76	200	13.8	600	Hot Clearance Rotors: 180°F (82°C) to 300°F (149°C)
5070	.440	1.666	260	59.1	4"	102	--	--	200	13.8	600	
5080	.754	2.854	450	102	6"	152	--	--	200	13.8	600	

NOTE: Consult factory for available rectangular flange inlets. Dimensions are for guidance purposes only. Contact your SPX FLOW Representative if more detailed measurements are needed.

* For capacities above 450 GPM (102.2 m³/hr) see bulletin FH-1725 for 6" and 8" 420/520 UHC (ECP rotors). For Lobe rotors up to 525 GPM (119.2 m³/hr see bulletin FH-1733 for UL (Lobe rotors) Series of pumps. **Contact application engineering for higher pressure or higher temperature applications.

Tru-Fit™ Universal 5000 Industrial Series

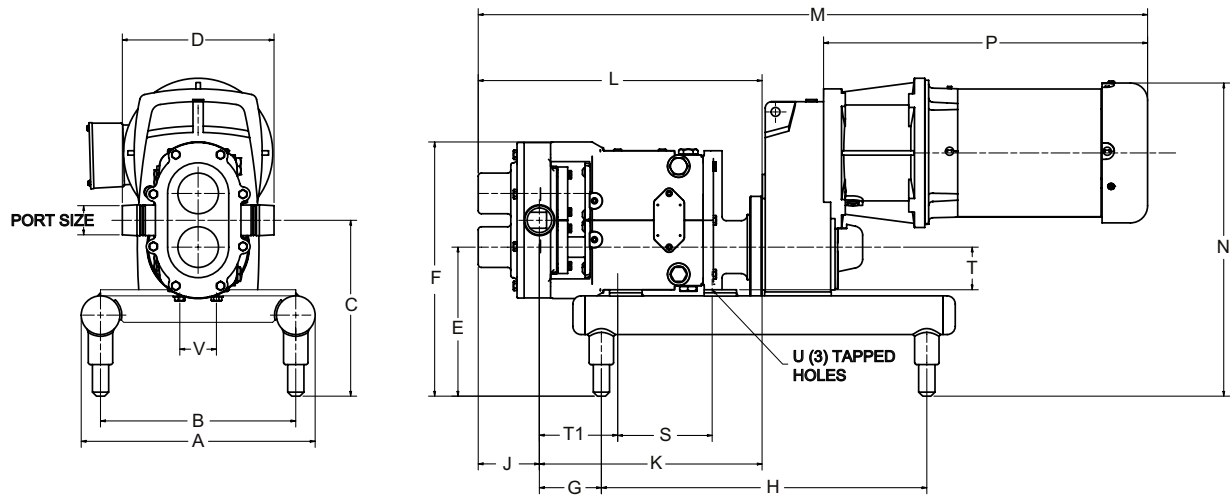

MODEL		A	B	C	D (NPT)	D (150# FLANGE)	E	F	G	H	J	K
5040	in	14.38	12	10.81	9.37	11.91	9.16	15.62	3.81	20	3.76	13.69
	mm	365	305	275	238	303	233	397	97	508	96	348
5050	in	18.38	16	12.48	11.62	13.25	10.23	19.04	3.71	28	4.12	18.09
	mm	467	406	317	295	337	260	484	94	711	105	459
5060	in	18.38	16	12.48	11.63	13.5	10.23	19.04	4.47	28	4.31	18.85
	mm	467	406	317	295	343	260	484	114	711	109	479
5070	in	20.88	18	14.51	--	14.75	11.51	23.19	4.57	36	6.75	20.82
	mm	530	457	369	--	375	292	589	116	914	171	529
5080	in	26.88	24	16.07	--	16	12.57	25.82	--	48	8.31	18.5
	mm	683	610	408	--	406	319	656	--	1219	211	470

MODEL		L	M	N	P	S	T	T1	PORT SIZE	U	V
5040	in	17.44	41.14	19.25	19.91	5.81	2.62	4.81	1½" - 11½" NPT	3/8" - 16 X 0.62	2.25
	mm	443	1045	489	506	148	67	122			57
5050	in	22.21	57.51	24.46	29.31	8.13	3.50	5.71	2" - 11½" NPT	½" - 13 X 0.88	3.50
	mm	564	1461	621	744	207	89	145			89
5060	in	23.16	58.46	24.46	29.31	8.13	3.50	6.47	2½" - 8 NPT	½" - 13 X 0.88	3.50
	mm	588	1485	621	744	207	89	164			89
5070	in	27.57	66.78	29.05	32.67	10	4.50	7.07	4" - 150# FLANGE	½" - 13.X 1.0	5.375
	mm	700	1696	738	830	254	114	180			137
5080	in	30.68	82.13	33.49	42.47	10.01	5.06	8.49	6" - 150# FLANGE	½" - 13.X 1.0	5.375
	mm	779	2086	851	1079	254	129	216			137

BEHIND EVERY WAUKESHA UNIVERSAL PUMP

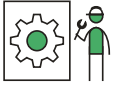

Engineering

Research, design and application engineers at SPX FLOW possess extensive backgrounds in their respective fields. You can draw on this experience to solve pumping problems or to counsel on process systems design. The imagination and resourcefulness of our engineers have often helped improve our customers' profits through production efficiencies.



Testing

Ideas do not remain abstract long at SPX FLOW. Application of our products to our customer's specific needs often requires practical testing using real-world parameters. We have a fully equipped and staffed facility for this purpose. For example, the Rheology Laboratory tests applications involving highly viscous fluids.



Sales & Service Network

SPX FLOW's trained sales and application engineers are always available for personal consultation to help solve any installation or operational problem. A large number of fully trained SPX FLOW stocking distributors throughout the country and around the world provide quality Waukesha Universal replacement parts and service.



Quality Control

To maintain the product line's reputation for quality and to assure that every unit is shipped "ready to install," each Waukesha pump is thoroughly inspected at every stage of manufacturing and assembly and then tested for design specification.



Metallurgical Control

SPX FLOW's reputation for pump reliability under severe operating conditions is directly related to carefully controlled casting production and consistency of metallurgical properties. It is this control that assures castings of uniform analysis that will perform dependably under all operating conditions.

WHEN IT IS TIME TO REPAIR

Factory Remanufacturing Program

- No need to return your pump until you receive your new remanufactured pump.
- Substantial savings over new pump.
- Only OEM genuine parts are used in the remanufacturing process and you receive a guaranteed warranty and quality certificate with each pump.
- New pumps eligible for Remanufacturing Program twice.

SPX FLOW Certified Pump Repair Centers

- Local distributors with factory trained and certified service technicians.
- Quick local response.
- Genuine WCB parts.
- Flexible repair programs to meet your needs.
- Local warranty.

SPX FLOW Warranty

Seller warrants its products to be free from defects in materials and workmanship for a period of one (1) year from the date of shipment. This warranty shall not apply to products which require repair or replacement due to normal wear and tear or to products which are subjected to accident, misuse or improper maintenance. This warranty extends only to the original buyer. Products manufactured by others but furnished by seller are exempted from this warranty and are limited to the original manufacturer's warranty.

Waukesha Cherry-Burrell®

PRODUCT INFORMATION AT YOUR FINGERTIPS

eXpress App

With the new eXpress app, accessing information on a SPX FLOW product is quick and easy.

Simply scan a serial number or QR code and:

- Watch product videos
- Download manuals and drawings
- Receive faster responses to inquiries
- Quick access to where to buy
- Register customer equipment

Scan and Download the
eXpress App today

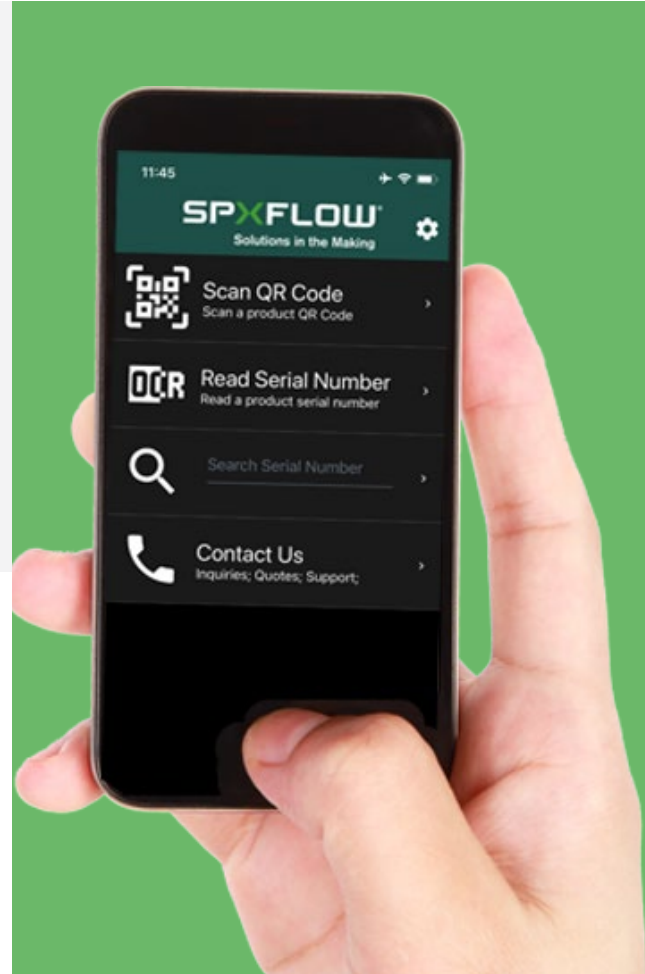

SPXFLOW®

SPX FLOW, Inc. reserves the right to incorporate our latest design and material changes without notice or obligation. Design features, materials of construction and dimensional data, as described in this bulletin, are provided for your information only and should not be relied upon unless confirmed in writing. Please contact your local sales representative for product availability in your region. The green ">" is a trademark of SPX FLOW, Inc.

For more information, visit www.spxflow.com.