

G-Chem Chemical Injection Pump

3A5028G

EN

Electric pump for injecting chemicals at well sites. For professional use only.

Not approved for use in explosive atmospheres. See pages 3 and 4 for motor approvals, including hazardous location motors.

See page 3 for model information, including maximum working pressure.



Important Safety Instructions

Read all warnings and instructions in this manual before using the equipment. Save all instructions.

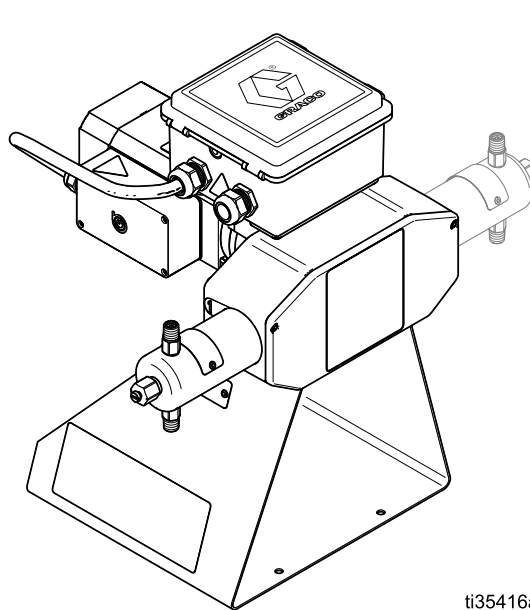

ti35416a

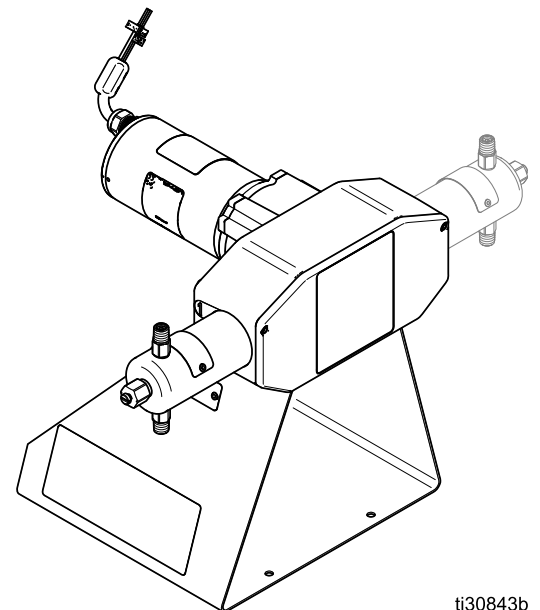

ti30843b

Contents



Related Manuals	2	Operation	18
Models and Approvals	3	Pressure Relief Procedure	18
G-Chem Fixed Speed Pumps	3	Flush the Equipment	18
G-Chem Variable Speed Pumps	4	Prime the Pump	19
Fluid Modules	5	Calibrate Chemical Dosage	19
Drive Modules	5	Preventive Maintenance Schedule	21
Configuration Number Matrix	6	Tighten Threaded Connections	21
G-Chem Assembly Configuration Code	6	Tighten Packings	21
Drive Module Configuration Code	7	Storage	21
Fluid Module Configuration Code	8	Troubleshooting	22
Warnings	9	Repair	23
Component Identification	11	Pump Repair	23
Installation	12	Parts	26
Grounding	12	G-Chem Fixed Speed Drive Module	26
Accessories	12	G-Chem Variable Speed Drive Module	28
Flush Before Using Equipment	12	G-Chem Fluid Module	30
Typical Installation	13	Kits and Accessories	32
Choosing an Installation Location	15	Dimensions	33
Fluid Connections	15	G-Chem Fixed Speed Pump	33
Motor Electrical Connections	15	G-Chem Pump with Harrier AC	34
Second Pump Add-On	16	G-Chem Variable Speed Pump	35
		Mounting Holes	36
		Performance Charts	37
		Technical Specifications	39
		Graco Standard Warranty	40

Related Manuals

Manual No.	Description
3A4700	Harrier™ EZ Chemical Injection Controller
3A4047	Harrier® AC Chemical Injection Controller

Models and Approvals

G-Chem Fixed Speed Pumps

Models	Configuration Number	Plunger Size	Number of Pumps	Seal Material	Maximum Working Pressure psi (MPa, bar)	Voltage	Motor Approval
A23101	CI-12E-2XF-000-0	1/4 in.	Simplex	FKM	2500 (17.2, 172)	12 VDC	 Not approved for use in European Explosive atmosphere or Hazardous Location.
A23102	CI-12E-3XF-000-0	3/8 in.	Simplex	FKM	1500 (10.3, 103)	12 VDC	
A23103	CI-12E-5XF-000-0	1/2 in.	Simplex	FKM	800 (5.5, 55)	12 VDC	
A23107	CI-12E-2XG-000-0	1/4 in.	Simplex	HNBR	2500 (17.2, 172)	12 VDC	
A23108	CI-12E-3XG-000-0	3/8 in.	Simplex	HNBR	1500 (10.3, 103)	12 VDC	
A23109	CI-12E-5XG-000-0	1/2 in.	Simplex	HNBR	800 (5.5, 55)	12 VDC	
A23113	CI-12E-2XH-000-0	1/4 in.	Simplex	TFE/P	2500 (17.2, 172)	12 VDC	
A23114	CI-12E-3XH-000-0	3/8 in.	Simplex	TFE/P	1500 (10.3, 103)	12 VDC	
A23115	CI-12E-5XH-000-0	1/2 in.	Simplex	TFE/P	800 (5.5, 55)	12 VDC	
A23151	CI-12E-2XF-2XF-0	1/4 in.	Duplex	FKM	2500 (17.2, 172)	12 VDC	
A23152	CI-12E-3XF-3XF-0	3/8 in.	Duplex	FKM	1500 (10.3, 103)	12 VDC	
A23153	CI-12E-5XF-5XF-0	1/2 in.	Duplex	FKM	800 (5.5, 55)	12 VDC	
A23157	CI-12E-2XG-2XG-0	1/4 in.	Duplex	HNBR	2500 (17.2, 172)	12 VDC	
A23158	CI-12E-3XG-3XG-0	3/8 in.	Duplex	HNBR	1500 (10.3, 103)	12 VDC	
A23159	CI-12E-5XG-5XG-0	1/2 in.	Duplex	HNBR	800 (5.5, 55)	12 VDC	
A23163	CI-12E-2XH-2XH-0	1/4 in.	Duplex	TFE/P	2500 (17.2, 172)	12 VDC	
A23164	CI-12E-3XH-3XH-0	3/8 in.	Duplex	TFE/P	1500 (10.3, 103)	12 VDC	
A32165	CI-12E-5XH-5XH-0	1/2 in.	Duplex	TFE/P	800 (5.5, 55)	12 VDC	
A23501	CI-1AE-2XF-000-0	1/4 in.	Simplex	FKM	2500 (17.2, 172)	115 VAC	 Not approved for use in European Explosive atmosphere or Hazardous Location.
A23502	CI-1AE-3XF-000-0	3/8 in.	Simplex	FKM	1500 (10.3, 103)	115 VAC	
A23503	CI-1AE-5XF-000-0	1/2 in.	Simplex	FKM	800 (5.5, 55)	115 VAC	
A23507	CI-1AE-2XG-000-0	1/4 in.	Simplex	HNBR	2500 (17.2, 172)	115 VAC	
A23508	CI-1AE-3XG-000-0	3/8 in.	Simplex	HNBR	1500 (10.3, 103)	115 VAC	
A23509	CI-1AE-5XG-000-0	1/2 in.	Simplex	HNBR	800 (5.5, 55)	115 VAC	
A23513	CI-1AE-2XH-000-0	1/4 in.	Simplex	TFE/P	2500 (17.2, 172)	115 VAC	
A23514	CI-1AE-3XH-000-0	3/8 in.	Simplex	TFE/P	1500 (10.3, 103)	115 VAC	
A23515	CI-1AE-5XH-000-0	1/2 in.	Simplex	TFE/P	800 (5.5, 55)	115 VAC	
A23551	CI-1AE-2XF-2XF-0	1/4 in.	Duplex	FKM	2500 (17.2, 172)	115 VAC	
A23552	CI-1AE-3XF-3XF-0	3/8 in.	Duplex	FKM	1500 (10.3, 103)	115 VAC	
A23553	CI-1AE-5XF-5XF-0	1/2 in.	Duplex	FKM	800 (5.5, 55)	115 VAC	
A23557	CI-1AE-2XG-2XG-0	1/4 in.	Duplex	HNBR	2500 (17.2, 172)	115 VAC	
A23558	CI-1AE-3XG-3XG-0	3/8 in.	Duplex	HNBR	1500 (10.3, 103)	115 VAC	
A23559	CI-1AE-5XG-5XG-0	1/2 in.	Duplex	HNBR	800 (5.5, 55)	115 VAC	
A23563	CI-1AE-2XH-2XH-0	1/4 in.	Duplex	TFE/P	2500 (17.2, 172)	115 VAC	
A23564	CI-1AE-3XH-3XH-0	3/8 in.	Duplex	TFE/P	1500 (10.3, 103)	115 VAC	
A23564	CI-1AE-5XH-5XH-0	1/2 in.	Duplex	TFE/P	800 (5.5, 55)	115 VAC	

G-Chem Variable Speed Pumps

Models	Configuration Number	Plunger Size	Number of Pumps	Seal Material	Maximum Working Pressure psi (MPa, bar)	Voltage	Motor Approvals
A23201	CI-12F-2XF-000-0	1/4 in.	Simplex	FKM	2500 (17.2, 172)	12 VDC	 Class I Division 2 Groups A,B,C,D
A23202	CI-12F-3XF-000-0	3/8 in.	Simplex	FKM	1500 (10.3, 103)	12 VDC	
A23203	CI-12F-5XF-000-0	1/2 in.	Simplex	FKM	800 (5.5, 55)	12 VDC	
A23207	CI-12F-2XG-000-0	1/4 in.	Simplex	HNBR	2500 (17.2, 172)	12 VDC	
A23208	CI-12F-3XG-000-0	3/8 in.	Simplex	HNBR	1500 (10.3, 103)	12 VDC	
A23209	CI-12F-5XG-000-0	1/2 in.	Simplex	HNBR	800 (5.5, 55)	12 VDC	
A23213	CI-12F-2XH-000-0	1/4 in.	Simplex	TFE/P	2500 (17.2, 172)	12 VDC	
A23214	CI-12F-3XH-000-0	3/8 in.	Simplex	TFE/P	1500 (10.3, 103)	12 VDC	
A23215	CI-12F-5XH-000-0	1/2 in.	Simplex	TFE/P	800 (5.5, 55)	12 VDC	
A23251	CI-12F-2XF-2XF-0	1/4 in.	Duplex	FKM	2500 (17.2, 172)	12 VDC	
A23252	CI-12F-3XF-3XF-0	3/8 in.	Duplex	FKM	1500 (10.3, 103)	12 VDC	
A23253	CI-12F-5XF-5XF-0	1/2 in.	Duplex	FKM	800 (5.5, 55)	12 VDC	
A23257	CI-12F-2XG-2XG-0	1/4 in.	Duplex	HNBR	2500 (17.2, 172)	12 VDC	
A23258	CI-12F-3XG-3XG-0	3/8 in.	Duplex	HNBR	1500 (10.3, 103)	12 VDC	
A23259	CI-12F-5XG-5XG-0	1/2 in.	Duplex	HNBR	800 (5.5, 55)	12 VDC	
A23263	CI-12F-2XH-2XH-0	1/4 in.	Duplex	TFE/P	2500 (17.2, 172)	12 VDC	
A23264	CI-12F-3XH-3XH-0	3/8 in.	Duplex	TFE/P	1500 (10.3, 103)	12 VDC	
A23265	CI-12F-5XH-5XH-0	1/2 in.	Duplex	TFE/P	800 (5.5, 55)	12 VDC	
A23601	CI-1AG-2XF-000-0	1/4 in.	Simplex	FKM	2500 (17.2, 172)	115 VAC	
A23602	CI-1AG-3XF-000-0	3/8 in.	Simplex	FKM	1500 (10.3, 103)	115 VAC	
A23603	CI-1AG-5XF-000-0	1/2 in.	Simplex	FKM	800 (5.5, 55)	115 VAC	
A23607	CI-1AG-2XG-000-0	1/4 in.	Simplex	HNBR	2500 (17.2, 172)	115 VAC	
A23608	CI-1AG-3XG-000-0	3/8 in.	Simplex	HNBR	1500 (10.3, 103)	115 VAC	
A23609	CI-1AG-5XG-000-0	1/2 in.	Simplex	HNBR	800 (5.5, 55)	115 VAC	
A23613	CI-1AG-2XH-000-0	1/4 in.	Simplex	TFE/P	2500 (17.2, 172)	115 VAC	
A23614	CI-1AG-3XH-000-0	3/8 in.	Simplex	TFE/P	1500 (10.3, 103)	115 VAC	
A23615	CI-1AG-5XH-000-0	1/2 in.	Simplex	TFE/P	800 (5.5, 55)	115 VAC	
A23651	CI-1AG-2XF-2XF-0	1/4 in.	Duplex	FKM	2500 (17.2, 172)	115 VAC	
A23652	CI-1AG-3XF-3XF-0	3/8 in.	Duplex	FKM	1500 (10.3, 103)	115 VAC	
A23653	CI-1AG-5XF-5XF-0	1/2 in.	Duplex	FKM	800 (5.5, 55)	115 VAC	
A23657	CI-1AG-2XG-2XG-0	1/4 in.	Duplex	HNBR	2500 (17.2, 172)	115 VAC	
A23658	CI-1AG-3XG-3XG-0	3/8 in.	Duplex	HNBR	1500 (10.3, 103)	115 VAC	
A23659	CI-1AG-5XG-5XG-0	1/2 in.	Duplex	HNBR	800 (5.5, 55)	115 VAC	
A23663	CI-1AG-2XH-2XH-0	1/4 in.	Duplex	TFE/P	2500 (17.2, 172)	115 VAC	
A23664	CI-1AG-3XH-3XH-0	3/8 in.	Duplex	TFE/P	1500 (10.3, 103)	115 VAC	
A23665	CI-1AG-5XH-5XH-0	1/2 in.	Duplex	TFE/P	800 (5.5, 55)	115 VAC	

Fluid Modules

Plunger Size	Maximum Working Pressure psi (MPa, bar)
1/4 in.	2500 (17.2, 172)
3/8 in.	1500 (10.3, 103)
1/2 in.	800 (5.5, 55)

Drive Modules

Drive Configuration	Voltage	Motor
CI-12E-5x-0	12 VDC	fixed speed
CI-1AE-5x-x	115 VDC	fixed speed
CI-12F-5x-0	12 VDC	variable speed brushless
CI-1AG-5x-0	115 VAC	variable speed

Configuration Number Matrix

Check the identification plate (ID) for the 12-digit Configuration Number of your pump. Use the following matrix to define the components of your pump.

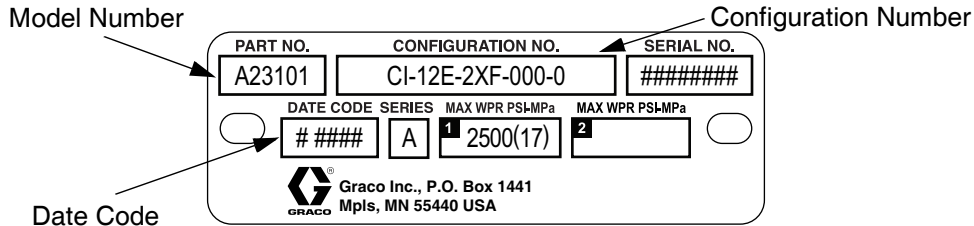

FIG. 1 Example of the G-Chem Assembly Identification Plate

G-Chem Assembly Configuration Code

Sample Configuration Number: CI-12E-2XF-000-0

			Side 1			Side 2			
CI	12	E	2	X	F	0	0	0	0
Chemical Injection	Voltage	Motor	Plunger Size	Plunger Coating	Seal Material	Plunger Size	Plunger Coating	Seal Material	Qualifier

Voltage		Motor		Side 1			Side 2			Qualifier	
				Plunger Size	Plunger Coating	Seal Material	Plunger Size	Plunger Coating	Seal Material		
12	12 VDC	E	Fixed Speed	2 1/4"	X Chromex	F FKM	0 None	0 None	0 None	0	None
1A	115 VAC	F	Continuous Injection Variable Speed, Brushless, C1D2	3 3/8"		G HNBR	2 1/4"	X Chromex	F FKM		
		G	Variable Speed, AC	5 1/2"		H TFE/P	3 3/8"		G HNBR		
							5 1/2"		H TFE/P		

NOTE: Not all combinations are possible.

NOTE: Approvals information is found on page 3. Models can be identified using the Voltage and Motor configuration codes and columns.

NOTE: Variable speed AC motor configurations are not rated for continuous duty applications.

Drive Module Configuration Code

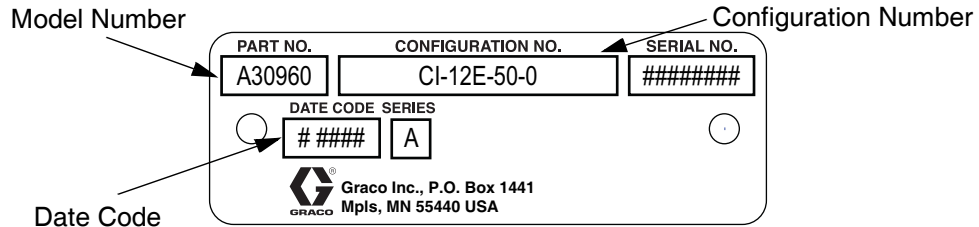

FIG. 2 Example of the Drive Module Identification Plate

Sample Configuration Number: CI-12E-50-0

CI	12	E	5	0	0
Chemical Injection	Voltage	Motor	Drive Side 1	Drive Side 2	Qualifier

Voltage		Motor		Drive Side 1		Drive Side 2		Qualifier	
12	12 VDC	E	Fixed Speed	5	Fluid Section Sizes 25 : 38 : 50	0	Simplex	0	None
1A	115 VAC	F	Continuous Injection Variable Speed, Brushless, C1D2			5	Fluid Section Sizes 25 : 38 : 50	A	Without Stand
		G	Variable Speed, AC					B	With Harrier AC Controller and Stand

NOTE: Not all combinations are possible.

NOTE: Variable speed AC motor configurations are not rated for continuous duty applications.

Fluid Module Configuration Code

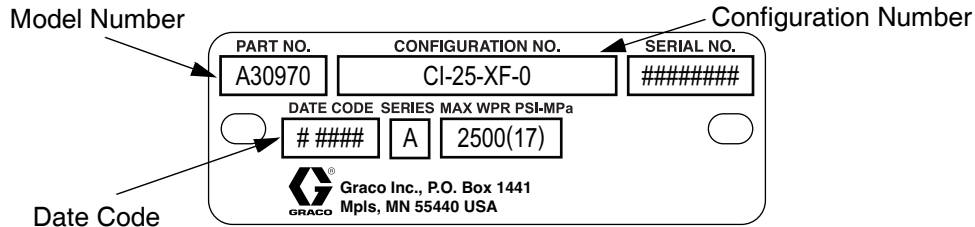

FIG. 3 Example of the Fluid Module Identification Plate

Sample Configuration Number: CI-25-XF-0

CI	25	X	F	0
Chemical Injection	Plunger Size	Plunger Coating	Seal Material	Qualifier











Plunger Size		Plunger Coating		Seal Material		Qualifier	
25	1/4"	X	Chromex	F	FKM	0	None
38	3/8"			G	HNBR		
50	1/2"			H	TFE/P		

NOTE: See **Second Pump Add-On**, page 16, for fluid section installation instructions.







NOTE: Fluid module pressure information is found on page 5.

Warnings

The following warnings are for the setup, use, grounding, maintenance, and repair of this equipment. The exclamation point symbol alerts you to a general warning and the hazard symbols refer to procedure-specific risks. When these symbols appear in the body of this manual or on warning labels, refer back to these Warnings. Product-specific hazard symbols and warnings not covered in this section may appear throughout the body of this manual where applicable.

 <h1 style="margin: 0;">WARNING</h1>	
 	<p>FIRE AND EXPLOSION HAZARD</p> <p>When flammable fluids are present in the work area be aware that flammable fumes can ignite or explode. To help prevent fire and explosion:</p> <ul style="list-style-type: none"> • Use equipment only in well ventilated area. • Eliminate all ignition sources, such as cigarettes and portable electric lamps. • Ground all equipment in the work area. • Keep work area free of debris, including rags and spilled or open containers of solvent. • Do not plug or unplug power cords or turn lights on or off when flammable fumes are present. • Use only grounded hoses. • Stop operation immediately if static sparking occurs or you feel a shock. Do not use equipment until you identify and correct the problem. • Keep a working fire extinguisher in the work area.
    	<p>SKIN INJECTION HAZARD</p> <p>High-pressure fluid from dispensing device, hose leaks, or ruptured components will pierce skin. This may look like just a cut, but it is a serious injury that can result in amputation. Get immediate surgical treatment.</p> <ul style="list-style-type: none"> • Do not put your hand over the fluid outlet. • Do not stop or deflect leaks with your hand, body, glove, or rag. • Follow the Pressure Relief Procedure when you stop dispensing and before cleaning, checking, or servicing equipment. • Tighten all fluid connections before operating the equipment. • Check hoses and couplings before each use. Replace worn or damaged parts immediately.
 	<p>ELECTRIC SHOCK HAZARD</p> <p>This equipment must be grounded. Improper grounding, setup, or usage of the system can cause electric shock.</p> <ul style="list-style-type: none"> • Turn off and disconnect power at main switch before disconnecting any cables and before servicing or installing equipment. • Connect only to grounded power source. • All electrical wiring must be done by a qualified electrician and comply with all local codes and regulations.

⚠️ WARNING

 	<p>MOVING PARTS HAZARD</p> <p>Moving parts can pinch, cut or amputate fingers and other body parts.</p> <ul style="list-style-type: none"> • Keep clear of moving parts. • Do not operate equipment with protective guards or covers removed. • Pressurized equipment can start without warning. Before checking, moving, or servicing equipment, follow the Pressure Relief Procedure and disconnect all power sources.
	<p>TOXIC FLUID OR FUMES HAZARD</p> <p>Toxic fluids or fumes can cause serious injury or death if splashed in the eyes or on skin, inhaled, or swallowed.</p> <ul style="list-style-type: none"> • Read Safety Data Sheet (SDS) to know the specific hazards of the fluids you are using. • Store hazardous fluids in approved containers, and dispose of it according to applicable guidelines.
	<p>PERSONAL PROTECTIVE EQUIPMENT</p> <p>Wear appropriate protective equipment when in the work area to help prevent serious injury, including eye injury, hearing loss, inhalation of toxic fumes, and burns. Protective equipment includes but is not limited to:</p> <ul style="list-style-type: none"> • Protective eyewear, and hearing protection. • Respirators, protective clothing, and gloves as recommended by the fluid and solvent manufacturers.
 	<p>EQUIPMENT MISUSE HAZARD</p> <p>Misuse can cause death or serious injury.</p> <ul style="list-style-type: none"> • Do not operate the unit when fatigued or under the influence of drugs or alcohol. • Do not exceed the maximum working pressure or temperature rating of the lowest rated system component. See Technical Specifications in all equipment manuals. • Use fluids and solvents that are compatible with equipment wetted parts. See Technical Specifications in all equipment manuals. Read fluid and solvent manufacturers' warnings. For complete information about your material, request Safety Data Sheet (SDS) from material supplier or retailer. • Turn off all equipment and follow the Pressure Relief Procedure when equipment is not in use. • Check equipment regularly. Repair or replace worn or damaged parts immediately with genuine manufacturer's replacement parts only. • Do not alter or modify equipment. Alterations or modifications may void agency approvals and create safety hazards. • Make sure all equipment is rated and approved for the environment in which you are using it. • Use equipment only for its intended purpose. Call your distributor for information. • Route hoses and cables away from traffic areas, sharp edges, moving parts, and hot surfaces. • Do not kink or over bend hoses or use hoses to pull equipment. • Keep children and animals away from work area. • Comply with all applicable safety regulations.

Component Identification

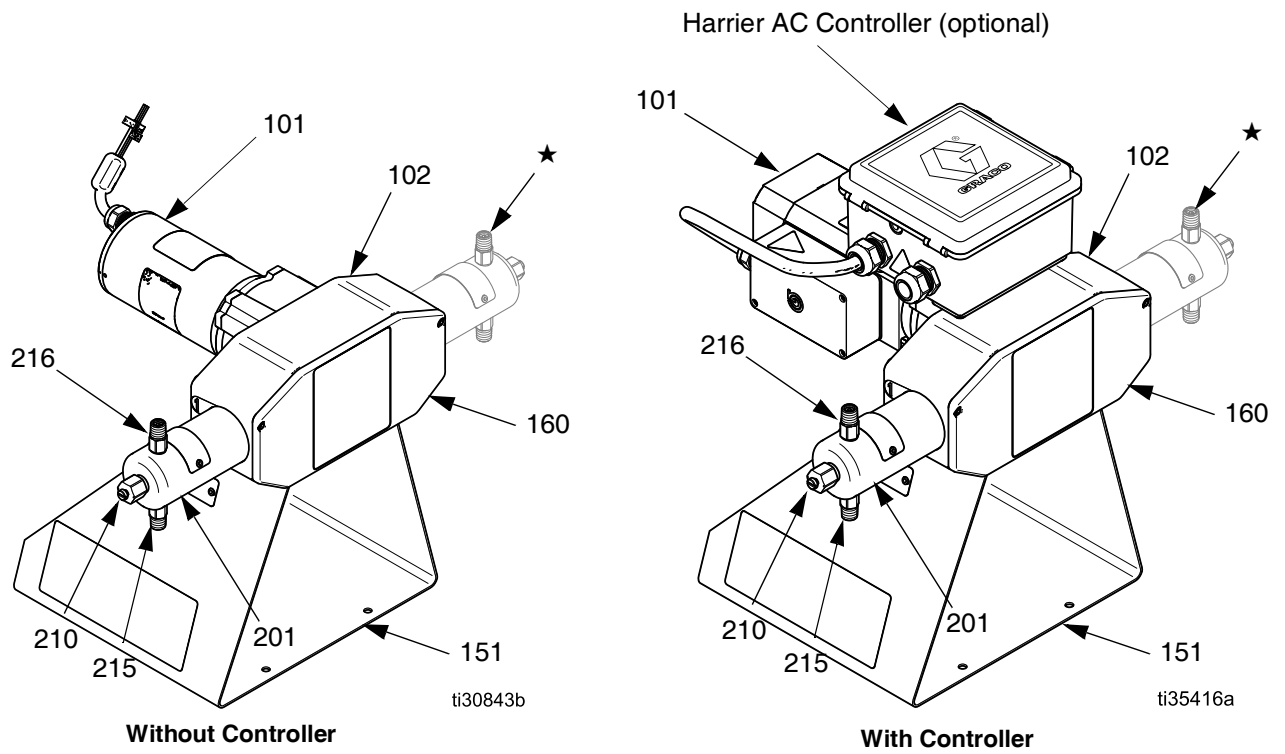

FIG. 4 G-Chem Pump Components

Key:

- 101 Motor
- 102 Drive Housing
- 151 Stand
- 160 Drive Guard
- 201 Pump Cylinder
- 210 Bleed Valve
- 215 Inlet Check Valve
- 216 Outlet Check Valve
- ★ Optional Second Pump

Installation

Grounding



The equipment must be grounded to reduce the risk of static sparking and electric shock. Electric or static sparking can cause fumes to ignite or explode. Improper grounding can cause electric shock. Grounding provides an escape wire for the electric current.

Pump: grounded through **Motor Electrical Connections** on page 15.

Fluid lines: use only electrically conductive lines.

Fluid supply container: follow local codes and regulations.

Controller: grounded through **Motor Electrical Connections** on page 15.

Accessories

Install the following required accessories in the order shown in **Typical Installation**, pages 13 and 14, using adapters as necessary. These required accessories must be supplied and installed by the customer before use.

- **Fluid filter (Y-Strainer) (included in K):** with a 60 mesh (250 micron) stainless steel element to filter particles from the fluid before it reaches the pump.
- **Fluid shutoff valves (L):** shuts off fluid flow.
- **Pressure relief valve (D):** overload protection.

Flush Before Using Equipment

The equipment was tested with lightweight oil, which is left in the fluid passages to protect parts. To avoid contaminating your fluid with oil, flush the equipment with a compatible solvent before using the equipment. See **Flush the Equipment**, page 18.

Typical Installation

Ordinary Location

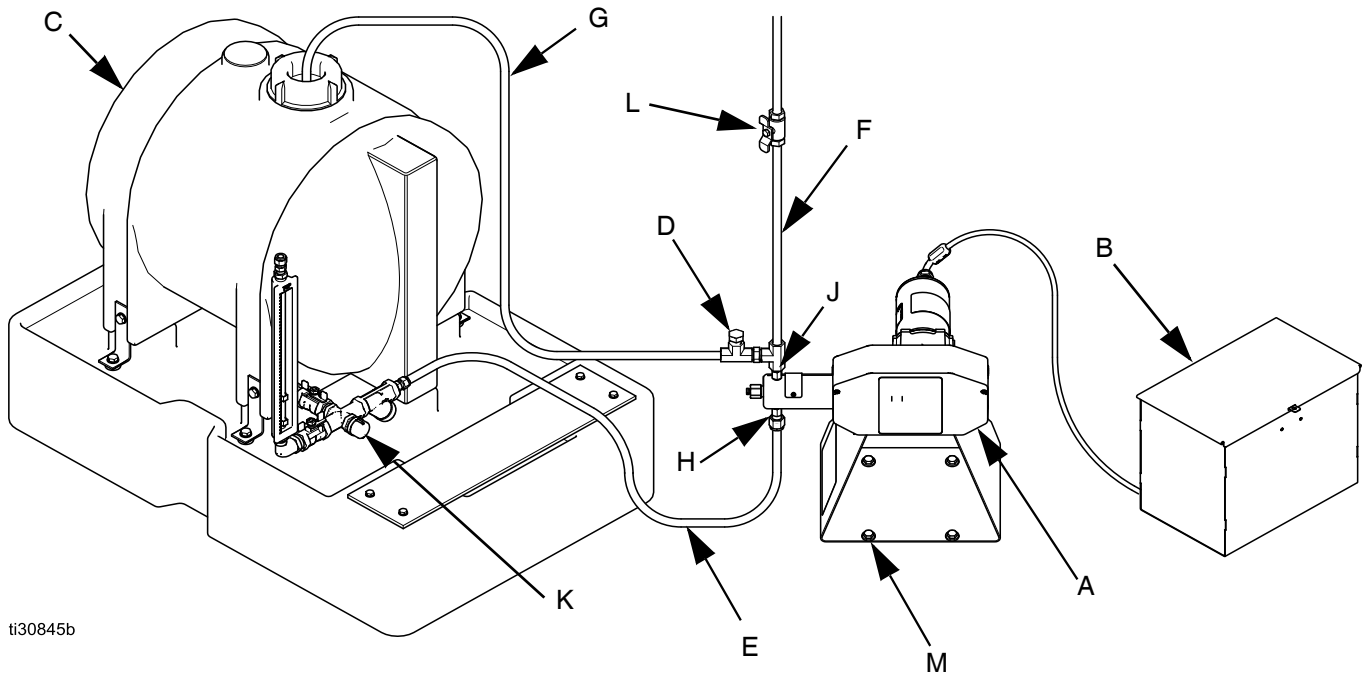

FIG. 5 Typical Installation in Ordinary Location with Generic Power Source

FIG. 5 is an example of an installation with a G-Chem chemical injection pump. Your installation may differ from what is shown here. (See **Accessories** on page 12.) The G-Chem pump (A) is the only component in FIG. 5 supplied by Graco. All other components are supplied by customer.

Key:

- A Chemical Injection Pump
- B Power Source
- C Tank
- D Pressure Relief Valve (Required)
- E Inlet Line
- F Outlet Line
- G Pressure Relief Line
- H Inlet Port
- J Outlet Port
- K Manifold Assembly (includes y-strainer and fluid shutoff valve (L))
- L Fluid Shutoff Valve (inlet & outlet) (Required)
- M Mounting Fasteners (Required)

Hazardous Location (C1D2)

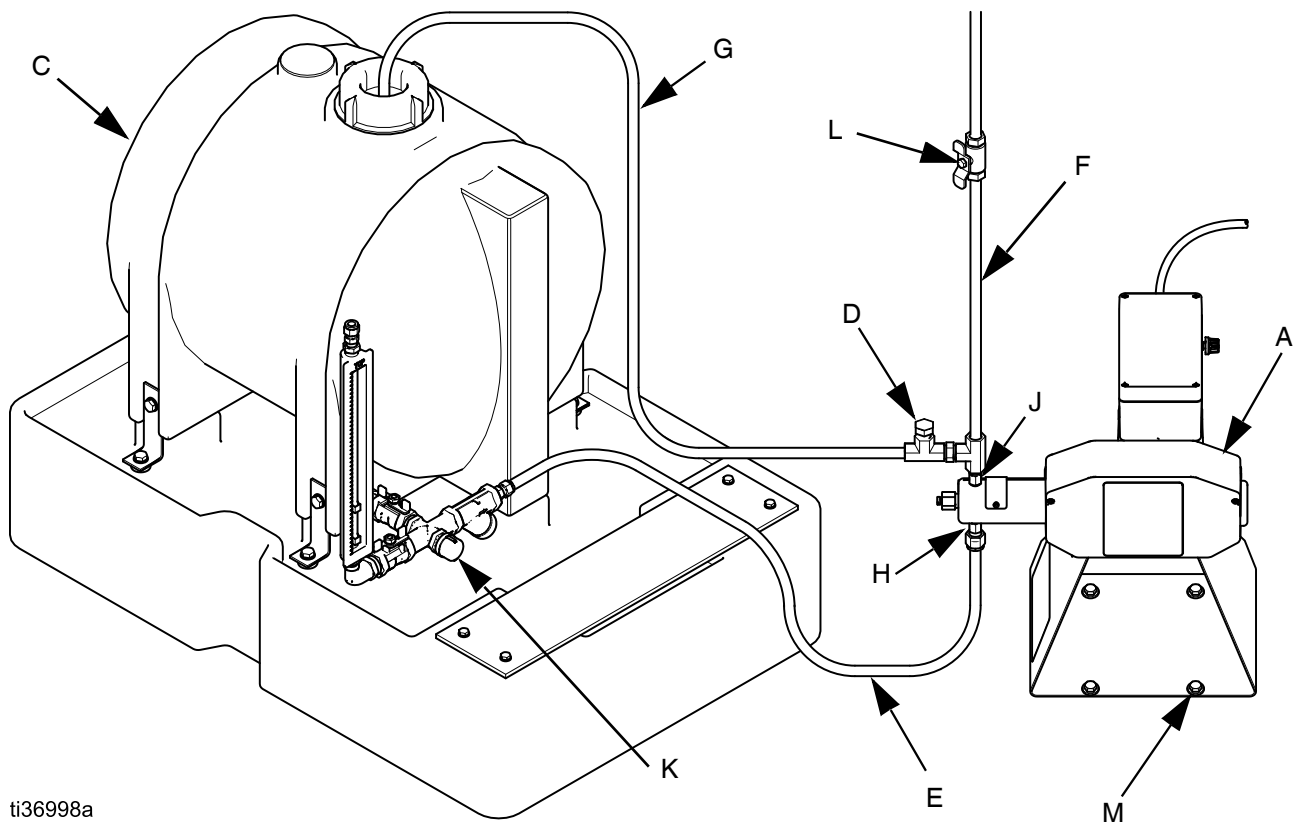

ti36998a

FIG. 6 Typical Installation in Hazardous Location

FIG. 6 is an example of an installation with a G-Chem chemical injection pump. Your installation may differ from what is shown here. (See **Accessories** on page 12.) The G-Chem pump (A) is the only component in FIG. 6 supplied by Graco. All other components are supplied by customer.

Key:

- A Chemical Injection Pump
- C Tank
- D Pressure Relief Valve (Required)
- E Inlet Line
- F Outlet Line
- G Pressure Relief Line
- H Inlet Port
- J Outlet Port
- K Manifold Assembly (includes y-strainer and fluid shutoff valve (L))
- L Fluid Shutoff Valve (inlet & outlet) (Required)
- M Mounting Fasteners (Required)

Choosing an Installation Location

1. Select a location that will adequately support the weight of the pump, as well as all plumbing and electrical connections.
2. Mount the pump using the mounting holes on the base of the stand (151) provided, with the mounting holes facing down. See **Mounting Holes** on page 36.
3. If you have a mounting configuration that requires installation in a manner different than depicted in FIG. 5, please contact your Graco distributor for assistance.

Fluid Connections

1. Remove and discard caps on check valves (215 and 216). See FIG. 4 on page 11.
2. Connect a 1/4 npt(f) fluid line from the fluid source to the inlet check valve (215).
3. Install a pressure relief valve (D) on the outlet side of the pump. See FIG. 5 on page 13.

NOTE: A pressure relief valve is available from Graco and can be connected back to the tank or directly to the outlet side of the pump. See **Kits and Accessories** on page 32.



In the event of an injection line blockage, to reduce the risk of skin injection and damage to the pump, ensure the pressure relief valve is set at or below the maximum working pressure of the pump.

4. Set the pressure relief valve at or below the maximum working pressure of the pump.
5. Connect a 1/4 npt(f) fluid line from the outlet check valve (J) to the injection point.

Motor Electrical Connections



To reduce the risk of electrical shock;

- All electrical wiring must be done by a qualified electrician and comply with all local codes and regulations.
- Install the pump with a dedicated means to disconnect the main power to the pump.

NOTICE

Branch circuit protection (user supplied) is required on all models. To avoid equipment damage:

- Never operate the pump without branch circuit protection installed.
- Branch circuit protection of the correct voltage and amperage must be installed in line with the power entry to the system.
- Branch circuit protection should be UL248 approved.
- See table below for branch circuit protection rating.

Configuration	Minimum Voltage	Branch Circuit Protection Rating
CI-12E-xx-x	12 VDC	15 A
CI-1AE-xx-x	115 VAC	3 A
CI-12F-xx-x	12 VDC	20A
CI-1AG-xx-x	115 VDC	4A

NOTICE

To avoid potential damage to equipment, verify that all system valves are open before connecting power to the pumps.

For Fixed Speed Pump

The pump assembly has 10 feet (3 m) of 1/2-inch, flexible cord connected to the motor with 10 in. (25.4 cm) motor leads.

1. Connect the green motor wire to a ground location.
2. Connect the white motor wire to the positive (+) output of the power source.
3. Connect the black motor wire to the negative (-) output of the power source.

For Variable Speed DC (model CI-12F-xx-x)

Refer to the motor manual included for wiring instructions and motor operation.

For Variable Speed AC (models CI-1AG-xx-x)

The pump assembly has 12 feet (3.7 m) of 1/2-inch, flexible cord connect to the motor with 18 in. (45.7 cm) motor leads.

1. Connect the green motor wire to a ground location.
2. Connect the white motor wire to the neutral output of the power source.
3. Connect the black motor wire to the line output of the power source.

Second Pump Add-On



1. Follow **Pressure Relief Procedure**, page 18.

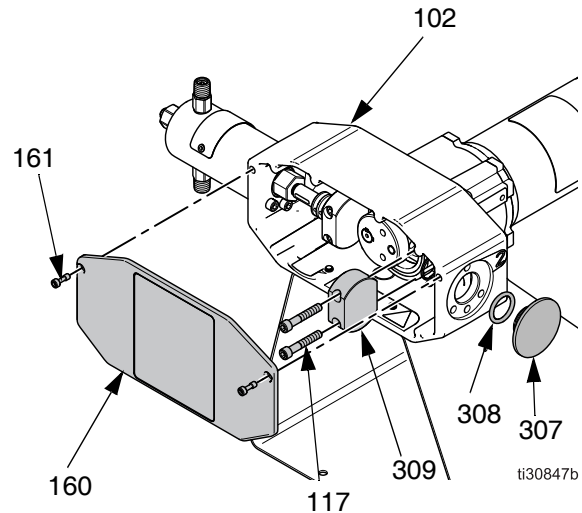
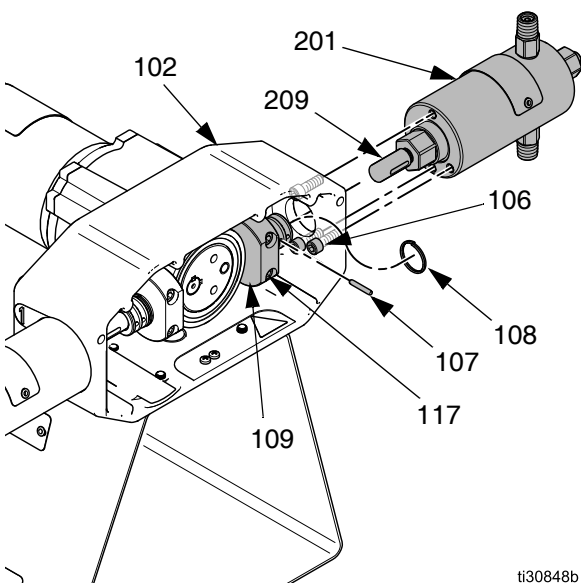

FIG. 7 Remove drive guard and plunger return block

2. Remove the drive guard (160). The fasteners (161) are captive and will remain with the drive guard (160).
3. Remove the plug (307) on the side of the housing (102) opposite of the existing pump. The plug (307) is held in place by an o-ring (308).
4. Remove the two screws (117), and then remove the plunger return block (309).



ti30848b

FIG. 8 Install second fluid module

5. Apply medium-strength Loctite (user-supplied) to the screws (117) and use them to secure the stroke adjuster (109). Tighten to 70-75 in-lbs.
6. Insert the plunger (209) into the stroke adjuster (109).
7. Apply medium-strength Loctite (user-supplied) to the screws (106) and use them to secure the fluid cylinder (201) to the housing (102). Tighten to 80-90 in-lbs.
8. Insert pin (107) to the desired stroke length and slide the split ring (108) to the slot to cover the pin. (See **Stroke Adjustment** on page 20.)
9. Replace drive guard (160).

Operation

Pressure Relief Procedure

 Follow the Pressure Relief Procedure whenever you see this symbol.



This equipment stays pressurized until pressure is manually relieved. To help prevent serious injury from pressurized fluid, such as skin injection and splashing fluid, follow the **Pressure Relief Procedure** when you stop dispensing and before cleaning, checking, or servicing the equipment.

NOTE: Always discharge fluid into an approved container or location.

1. Disconnect main power from pump.
2. Shut off the inlet and outlet lines using shutoff valves (L). See FIG. 5 on page 13.
3. Slowly loosen the fitting connected to the outlet check valve (216) to relieve downstream fluid pressure. See FIG. 4 on page 11.
4. Open the pipe plug (210) on the end of the pump cylinder (201) to relieve internal pump pressure.
5. Disconnect and cap inlet (E) and outlet (F) fluid lines.

Flush the Equipment

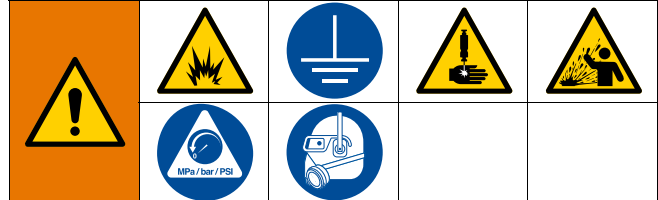

To avoid fire and explosion, always ground equipment and waste container. To avoid static sparking and injury from splashing, always flush at the lowest possible pressure.

- Check fittings for leaks and tighten as necessary.
 - Flush with a fluid that is compatible with the fluid being dispensed and the equipment's wetted parts.
1. Follow the **Pressure Relief Procedure**.
 2. Connect the inlet check valve (215) to the supply source of the flushing fluid. See FIG. 4 on page 11.
 3. Connect the outlet check valve (216) to a waste reservoir.
 4. Run the pump until the dispensed fluid is predominantly flushing fluid.

NOTE: If using a Harrier EZ controller, refer to the "Prime Mode" section in the Harrier EZ controller manual. If using a Harrier AC controller, refer to the "Priming the Lines" section of the Harrier AC controller manual. (See **Related Manuals** on page 2.)

5. Follow the **Pressure Relief Procedure**.

Prime the Pump



NOTICE

To avoid potential damage to equipment, verify that all system valves are open before priming the pump.

1. Verify all system valves are open.
2. Verify all connections and fluid lines are tight.
3. In order to prime the pump, slowly loosen the outlet fitting.
4. Turn the pump on and begin cycling.

NOTE: If using a Harrier EZ controller, refer to the “Prime Mode” section in the Harrier EZ controller manual. If using a Harrier AC controller, refer to the “Priming the Lines” section of the Harrier AC controller manual. (See **Related Manuals** on page 2.)

5. The pump is primed when discharge has transitioned from air, to bubbly liquid chemical, to pure liquid chemical.
6. Tighten outlet fitting and verify that fluid has stopped draining from the port.

Calibrate Chemical Dosage



1. Begin the process by setting the cycle rate and/or stroke adjustment of the pump to an estimated setting for a desired flow rate. See **Baseline Chemical Dosage Settings**, page 20, for tables of cycles per minute (CPM), and corresponding gallons per day (GPD) and liters per day (LPD).
2. Follow the instructions provided with your calibration gauge in conjunction with the **Baseline Chemical Dosage Settings**, page 20.
3. Adjust the cycle rate and/or stroke adjustment accordingly after the test is performed. Increasing the cycle rate and/or stroke adjustment of the pump will increase the pump flow rate, while decreasing it will decrease the flow rate.
4. Repeat the instructions provided with your calibration gauge to verify changes.
5. Repeat steps 3 and 4, as necessary, until the desired flow rate is achieved.

Stroke Adjustment



This pump has three defined stroke adjustment positions.

1. Disconnect main power from pump.
2. Expose the drive shaft by loosening the fasteners (161) and removing the drive guard (160). The fasteners are captive and will remain with the drive guard.
3. Push the split ring (108) left or right to expose the dowel pin (107) in one of the stroke holes.
4. Push out the pin (107) using a screwdriver or punch.
5. Align the desired stroke hole (1/2, 3/4, or Full) with hole in the fluid plunger (209). Use a screwdriver to push in the pin (107).

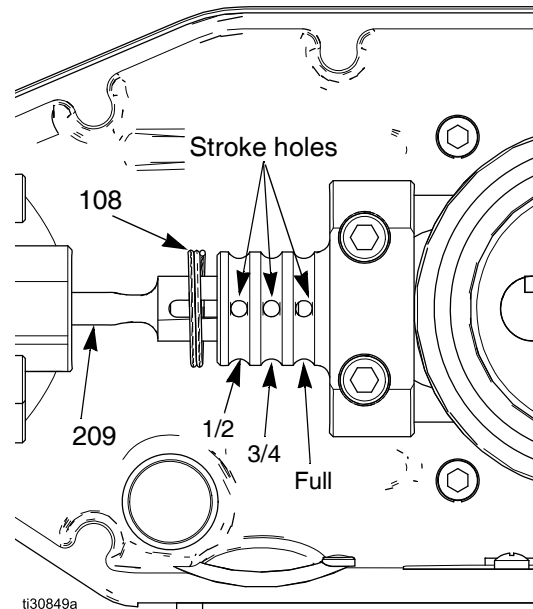

FIG. 9 Stroke adjustment positions

6. Push the split ring (108) into place to cover the pin.
7. Replace the drive guard (160) and tighten the fasteners (161).

Baseline Chemical Dosage Settings

See **Stroke Adjustment**, page 20, for stroke adjust settings. CPM (cycles per minute) is determined by controller settings for On/Off Time, or Cycles if using a Harrier-family chemical injection controller or variable speed motor. Adjust the controller settings to change the CPM. Motor speed, which affects CPM, is also affected by voltage and back pressure. To use these charts, find the flow rate above the desired injection rate for the correct-sized plunger. Adjust the stroke and controller settings accordingly for the corresponding CPM.

NOTE: Double values in the charts below for configurations with two pumps.

NOTE: CI-1AE pumps have a maximum CPM of 75. CI-12E pumps have a maximum CPM of 60.

CPM	1/4 in. Fluid Plunger Pumps			3/8 in. Fluid Plunger Pumps			1/2 in. Fluid Plunger Pumps		
	GPD (LPD)			GPD (LPD)			GPD (LPD)		
	Full Stroke	3/4 Stroke	1/2 Stroke	Full Stroke	3/4 Stroke	1/2 Stroke	Full Stroke	3/4 Stroke	1/2 Stroke
5	1.5 (5.8)	1.1 (4.3)	0.8 (2.9)	2.8 (10.4)	2.1 (7.8)	1.4 (5.2)	5.2 (19.7)	3.9 (14.8)	2.6 (9.8)
10	3.1 (11.6)	2.3 (8.7)	1.5 (5.8)	5.5 (20.8)	4.1 (15.6)	2.8 (10.4)	10.4 (39.4)	7.8 (29.5)	5.2 (19.7)
15	4.6 (17.4)	3.4 (13.0)	2.3 (8.7)	8.3 (31.3)	6.2 (23.5)	4.1 (15.6)	15.6 (59.1)	11.7 (44.3)	7.8 (29.5)
20	6.1 (23.2)	4.6 (17.4)	3.1 (11.6)	11.0 (41.7)	8.3 (31.3)	5.5 (20.8)	20.8 (78.8)	15.6 (59.1)	10.4 (39.4)
25	7.6 (29.0)	5.7 (21.7)	3.8 (14.5)	13.8 (52.1)	10.3 (39.1)	6.9 (26.1)	26.0 (98.5)	19.5 (73.8)	13.0 (49.2)
30	9.2 (34.7)	6.9 (26.1)	4.6 (17.4)	16.5 (62.5)	12.4 (46.9)	8.3 (31.3)	31.2 (118.1)	23.4 (88.6)	15.6 (59.1)
35	10.7 (40.5)	8.0 (30.4)	5.4 (20.3)	19.3 (73.0)	14.5 (54.7)	9.6 (36.5)	36.4 (137.8)	27.3 (103.4)	18.2 (68.9)
40	12.2 (46.3)	9.2 (34.7)	6.1 (23.2)	22.0 (83.4)	16.5 (62.5)	11.0 (41.7)	41.6 (157.5)	31.2 (118.1)	20.8 (78.8)
45	13.8 (52.1)	10.3 (39.1)	6.9 (26.1)	24.8 (93.8)	18.6 (70.4)	12.4 (46.9)	46.8 (177.2)	35.1 (132.9)	23.4 (88.6)
50	15.3 (57.9)	11.5 (43.4)	7.6 (29.0)	27.5 (104.2)	20.7 (78.2)	13.8 (52.1)	52.0 (196.9)	39.0 (147.7)	26.0 (98.5)
55	16.8 (63.7)	12.6 (47.8)	8.4 (31.9)	30.3 (114.7)	22.7 (86.0)	15.1 (57.3)	57.2 (216.6)	42.9 (162.5)	28.6 (108.3)

CPM	1/4 in. Fluid Plunger Pumps			3/8 in. Fluid Plunger Pumps			1/2 in. Fluid Plunger Pumps		
	GPD (LPD)			GPD (LPD)			GPD (LPD)		
	Full Stroke	3/4 Stroke	1/2 Stroke	Full Stroke	3/4 Stroke	1/2 Stroke	Full Stroke	3/4 Stroke	1/2 Stroke
60	18.4 (69.5)	13.8 (52.1)	9.2 (34.7)	33.0 (125.1)	24.8 (93.8)	16.5 (62.5)	62.4 (236.3)	46.8 (177.2)	31.2 (118.1)
65	19.9 (75.3)	15.0 (56.4)	10.0 (37.6)	35.8 (135.5)	26.9 (101.6)	17.9 (67.9)	67.6 (256.0)	50.7 (192.0)	33.8 (127.9)
70	21.5 (81.1)	16.1 (60.8)	10.7 (40.5)	38.5 (146.0)	28.9 (109.4)	19.3 (72.9)	92.8 (275.9)	54.6 (206.7)	36.4 (137.8)
75	23.0 (86.9)	17.3 (65.1)	11.5 (43.4)	41.3 (156.4)	31.0 (117.3)	20.6 (78.1)	78.0 (295.4)	58.5 (221.5)	39.0 (147.6)

Maintenance

Preventive Maintenance Schedule

The operating conditions of your particular pump determines how often maintenance is required. Establish a preventive maintenance schedule by recording when and what kind of maintenance is needed, and then determine a regular schedule for checking your pump.

Tighten Threaded Connections

Check that all threaded connections are tight at routine intervals.

Tighten Packings

The packings included in your pump have the ability to be adjusted to stop leaks that develop when the seals are worn. If a leak develops in the pump’s fluid section, tighten the packing nut clockwise by 1/16th of a turn, or lower, until the leak is eliminated. The life of the packing can be affected by over-tightening the packings. If the packing nut needs to be tightened repeatedly after short intervals, replace the packing.

Storage

If the pump is going to be stored for long periods, it is recommended that the pump be flushed with a light-weight oil or rust prohibiter to protect pump components. Store the pump with protective fluid inside whenever possible.

Troubleshooting

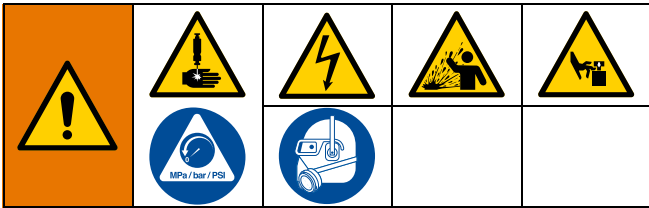

1. Follow **Pressure Relief Procedure**, page 18, before checking or repairing the pump.
2. Check all possible problems and causes before disassembling the pump.

Problem	Cause	Solution
Air bubbles in fluid	Suction line is loose	Tighten
Fluid leaking	Loose fittings	Tighten fittings
	Worn or damaged seals and/or packing	Adjust or tighten seals and/or packing. If leak persists, replace seals and/or packing.
Motor running but no fluid moving	Pump stalled	Check pump for contamination
	Air in pump	Prime pump
	Worn or damaged check valve seals	Replace inlet and outlet check valves
Motor not running	Electrical	Check electrical connectors
	Blown fuse	Replace fuse
	Packings too tight	Loosen or replace packing
Blown fuse	System valves are closed	Ensure all system valves are open.
Fluid leaking from weep hole on fluid head	Packing nut too loose	Tighten packing nut
	Worn or damaged packing	Replace packing

Repair



Pump Repair

1. Follow the **Pressure Relief Procedure** on page 18.
2. Expose the drive shaft by loosening the fasteners (161) and removing the guard (160). The fasteners are captive and will remain with the guard.

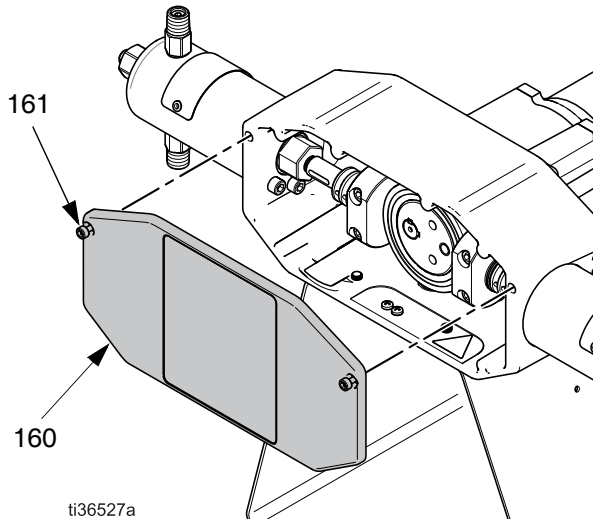

FIG. 10 Exposing the drive shaft

3. Remove the screws (106) and slide the fluid cylinder (201) away from the drive housing (102).

NOTE: The plunger (209) will stay within the drive housing (102) unless the dowel pin (107) is removed. The dowel pin is held in place by a split ring (108) that can be pushed aside to free the pin. It is not necessary to remove the plunger (209) unless it is damaged and needs to be replaced.

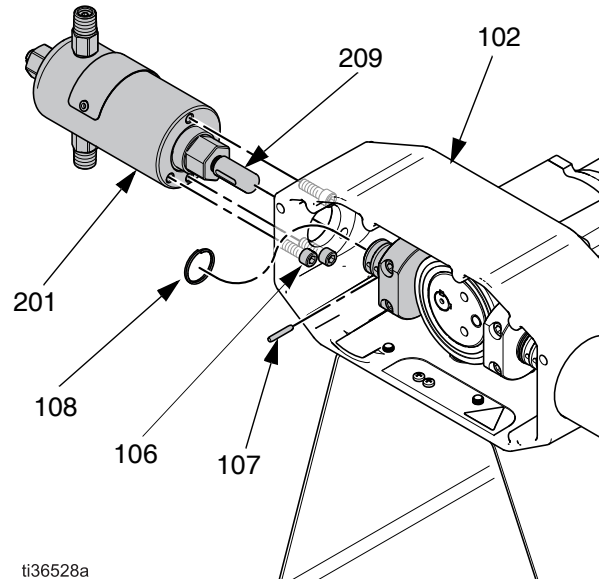
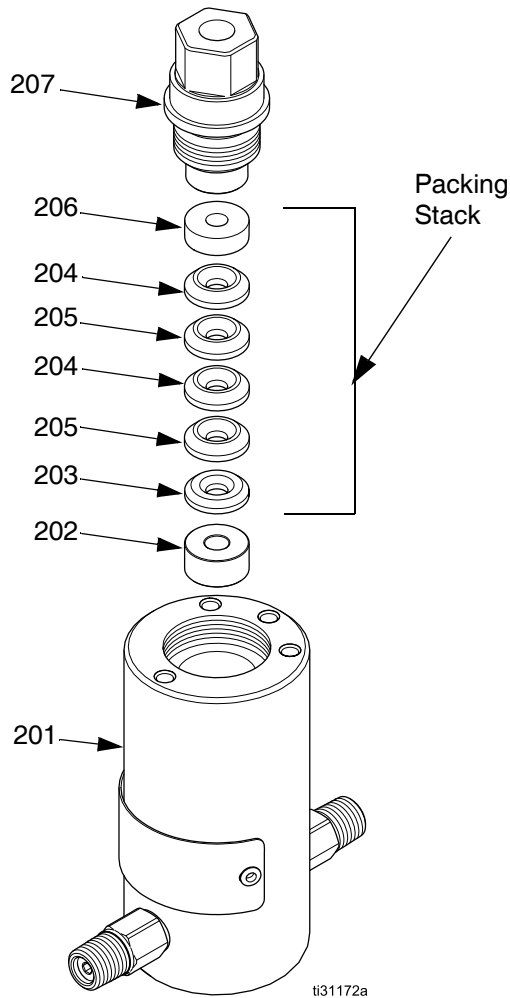

FIG. 11 Removing the fluid cylinder

- Remove packing nut (207) from fluid cylinder (201).



- Slide the fluid cylinder (201) onto the plunger (209) and use the screws (106) to attach the fluid cylinder (201) to the drive housing.

NOTE: Install the plunger (209) first if it was removed, and secure it with the dowel pin (107) and split ring (108). Refer to **Stroke Adjustment**, on page 20, for specific placement of the pin (107) and ring (108).

- Replace the guard (160) and tighten the fasteners (161).

FIG. 12 G-Chem Pump Repair

- Carefully remove the packing stack (203-206) and the spacer (202) from the fluid cylinder (201).
- Replace the packing stack (203-206). Inspect the spacer (202) and replace, if necessary. Lubricate prior to reassembly.
- Replace the packing nut (207) assembly into fluid cylinder. Tighten until hand tight and the flange of the packing nut (207) is below the surface of the fluid cylinder (201).

Parts

G-Chem Fixed Speed Drive Module

Configuration CI-12E-2XF-000-0 shown

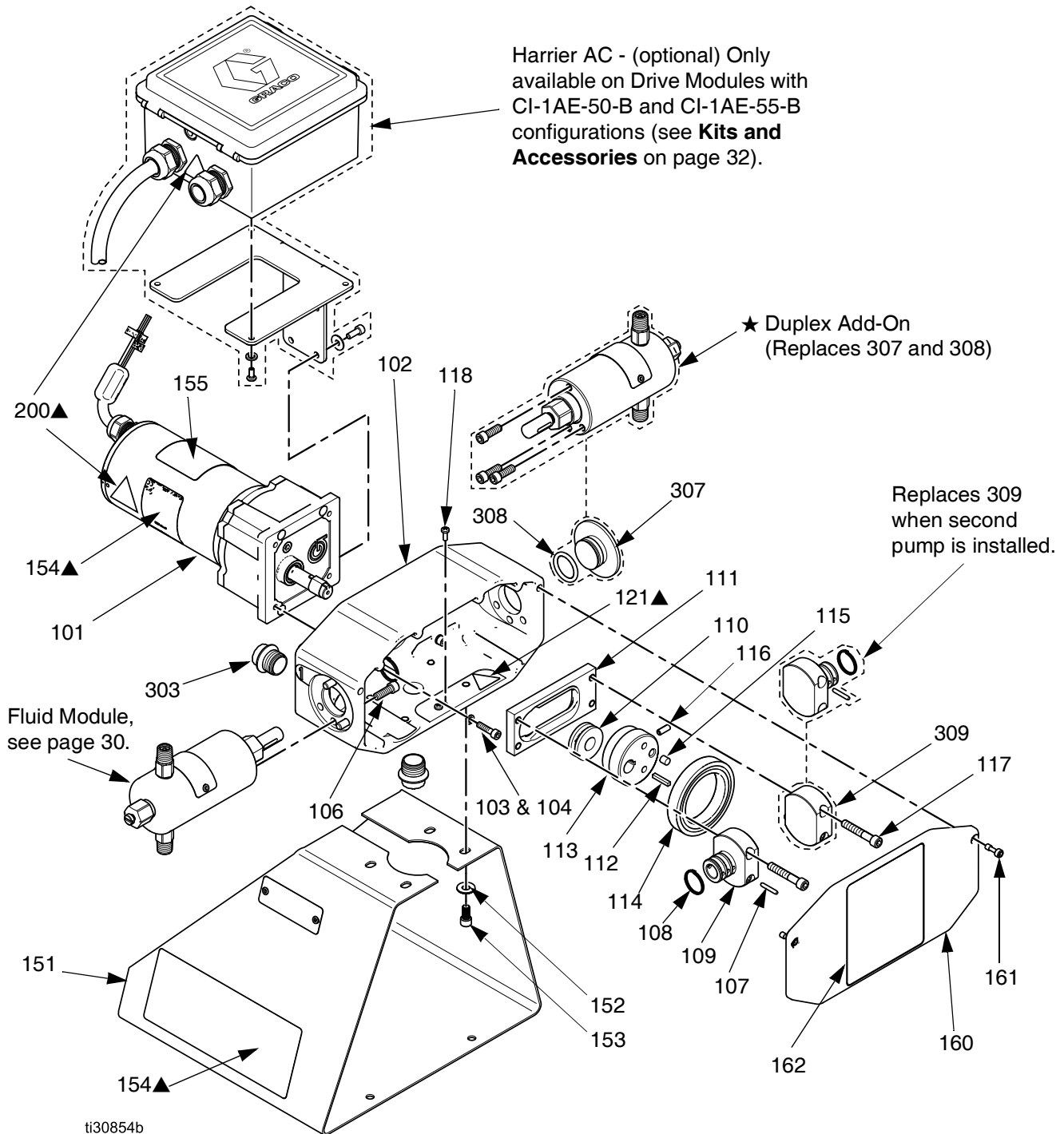

G-Chem Fixed Speed Drive Module Parts List

Ref.	Part	Description	Qty
101	B32002	Motor, 12 VDC	1
	B32761	Motor, 115 VAC	1
102	--	Housing, Drive	1
103	112906	Washer, Lock, Spring	4
104	120961	Screw, Socket Head Cap	4
106‡	100644	Screw, Socket Head Cap	3
107	B32268	Pin, Dowel	1
108	--	Split Ring, included with dowel pin (ref 107)	1
109	--	Adjuster, Stroke	1
110	B32708	Bearing, CIP, Carriage	1
111	--	Carriage, Plunger Return	1
112	--	Square Key, included with CIP carriage bearing (ref 110) and CIP eccentric cam (ref 113)	1
113	B32084	Cam, Eccentric, CIP	1
114	--	Deep Groove Ball Bearing, included with CIP eccentric cam (ref 113)	1
115	--	Reed Sensor Magnet, included with CIP eccentric cam (ref 113)	1
116	--	Socket Head Cap Screw, included with CIP carriage bearing (ref 110) and CIP eccentric cam (ref 113)	1
117	15B588	Socket Head Cap Screw, included with plunger return block (ref 309)	4
118	--	Screw, Phillips	2
121▲	15H108	Pinch Hazard Warning Label	1
151	B32817	Pump Stand	1
152	115814	Flat Washer, included with pump stand (ref 151)	4
153	--	Socket Head Cap Screw, included with pump stand (ref 151)	4
154▲	17G318	Multiple Warning Safety Label	1
155	17S348	Max WPR Label	1
160	B32787	Drive Guard	1
161	--	Captive Screw, included with drive guard (ref 160)	2
162	--	Branding Label, included with drive guard (ref 160)	1

Ref.	Part	Description	Qty
200▲	15G303	Shock Hazard Warning Label (CI-1Ax-xxx-xxx-x models only)	1
307	--	Plug, Simplex	1
308	156401	O-Ring	1
309	B32711	Block, Plunger Return	1
330	--	Cap Plug, Threaded	2

▲ Replacement Danger and Warning labels, tags, and cards are available at no cost.

G-Chem Variable Speed Drive Module

Configuration CI-12F-2XF-000-0 shown

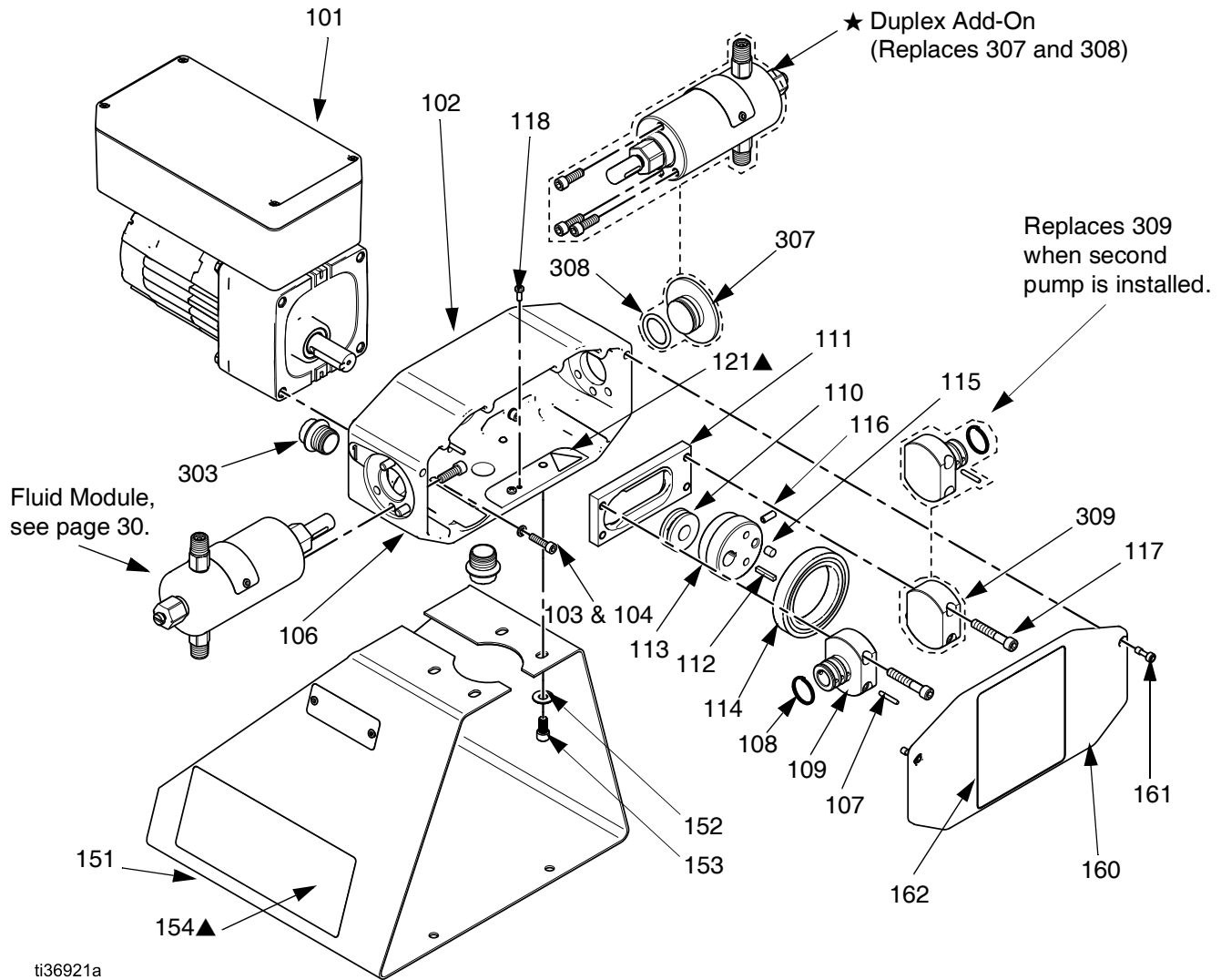

G-Chem Variable Speed Drive Module Parts List

Ref.	Part	Description	Qty
101	B32032	Motor, 12 VDC, variable speed	1
	B32705	Motor, 115 VAC, variable speed	1
102	--	Housing, Drive	1
103	104123	Washer, Lock, Spring	4
104	128610	Screw, Socket Head Cap	4
106‡	100644	Screw, Socket Head Cap	3
107	B32268	Pin, Dowel	1
108	--	Split Ring, included with dowel pin (ref 107)	1
109	--	Adjuster, Stroke	1
110	B32709	Bearing, CIP, Carriage	1
111	--	Carriage, Plunger Return	1
112	--	Square Key, included with CIP carriage bearing (ref 110) and CIP eccentric cam (ref 113)	1
113	B32411	Cam, Eccentric, CIP	1
114	--	Deep Groove Ball Bearing, included with CIP eccentric cam (ref 113)	1
115	--	Reed Sensor Magnet, included with CIP eccentric cam (ref 113)	1
116	--	Socket Head Cap Screw, included with CIP carriage bearing (ref 110) and CIP eccentric cam (ref 113)	1
117	15B588	Socket Head Cap Screw, included with plunger return block (ref 309)	4
118	--	Screw, Phillips	2
121▲	15H108	Pinch Hazard Warning Label	1
151	B32817	Pump Stand	1
152	115814	Flat Washer, included with pump stand (ref 151)	4
153	--	Socket Head Cap Screw, included with pump stand (ref 151)	4
154▲	17G318	Multiple Warning Safety Label	1
160	B32787	Drive Guard	1
161	--	Captive Screw, included with drive guard (ref 160)	2
162	--	Branding Label, included with drive guard (ref 160)	1
307	--	Plug, Simplex	1
308	156401	O-Ring	1
309	B32711	Block, Plunger Return	1
330	--	Cap Plug, Threaded	2

▲ Replacement Danger and Warning labels, tags, and cards are available at no cost.

G-Chem Fluid Module

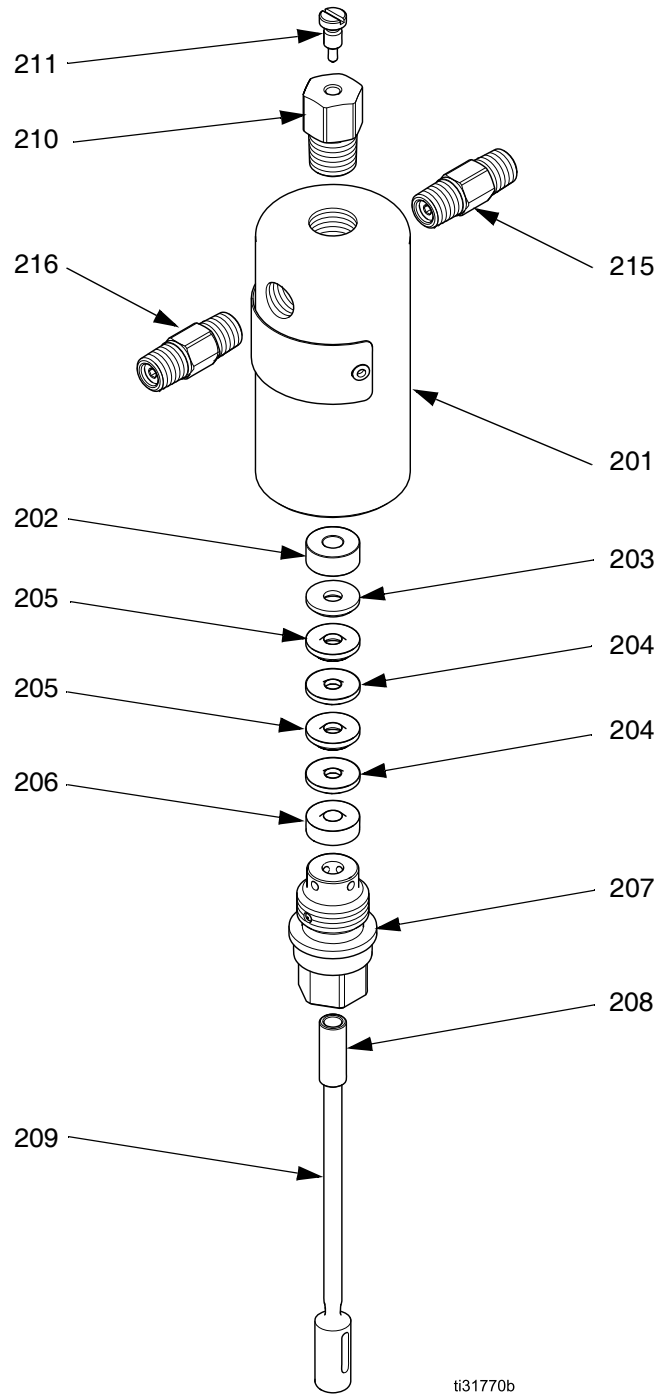

ti31770b

G-Chem Fluid Module Parts List

Ref.	Part	Description	Qty
201	See Kits and Accessories , page 32	Cylinder, Fluid	1
202	--	Spacer, Packing Nut	1
203	See Table 1	Adapter, Male, Vee Stack	1
204	See Table 1	Packing, Vee, Plastic	2
205	See Table 1	Packing, Vee, Rubber	2
206	See Table 1	Adapter, Female, Vee Stack	1
207	See Table 2	Nut, Packing	1
208	--	Sleeve Bearing, included with packing nut (ref 207)	1
209	See Table 3	Plunger	1
210	B32872	Bleed Valve Kit, includes bleed needle (ref 211)	1
211	17F572	Bleed Needle, included with bleed valve kit (ref 210)	1
215	B32733	Valve, Check, Inlet, FKM	1
	B32735	Valve, Check, Inlet, HNBR	1
	B32857	Valve, Check, Inlet, TFE/P	1
216	B32734	Valve, Check, Outlet, FKM	1
	B32736	Valve, Check, Outlet, HNBR	1
	B32858	Valve, Check, Outlet, TFE/P	1
217	--	Nylon Ball, included with packing nut (207)	1

Table 1: Packing Kit (includes ref. 203, 204, 205, & 206)

Ref	Part Numbers by Fluid Plunger Size Diameter			Qty.
	1/4 in.	3/8 in.	1/2 in.	
FKM				
203 - 206	B32784	B32782	B32780	1
HNBR				
203 - 206	B32785	B32783	B32781	1
TFE/P				
203 - 206	B32854	B32855	B32856	1

Table 2: Packing Nut

Ref	Part Numbers by Fluid Plunger Size Diameter			Qty.
	1/4 in.	3/8 in.	1/2 in.	
207	B32776	B32775	B32774	1

Table 3: Fluid Plunger

Ref	Part Numbers by Fluid Plunger Size Diameter			Qty.
	1/4 in.	3/8 in.	1/2 in.	
Chromex-Coated 17-4 Stainless Steel				
209	B32779	B32778	B32777	1

Kits and Accessories

Part No.	Description
B32045	225-750 PSI Pressure Relief Valve Kit
B32046	750-1500 PSI Pressure Relief Valve Kit
B32047	1500-2250 PSI Pressure Relief Valve Kit
B32048	2250-3000 PSI Pressure Relief Valve Kit
B32869	Simplex Plug Accessory Kit
B32798	Duplex Conversion Kit
B32872	Bleed Valve Accessory Kit
A30970	1/4" FKM: Chromex Fluid Module*
A30971	1/4" HNBR: Chromex Fluid Module*
A30972	1/4" TFE/P: Chromex Fluid Module*
A30980	3/8" FKM: Chromex Fluid Module*
A30981	3/8" HNBR: Chromex Fluid Module*
A30982	3/8" TFE/P: Chromex Fluid Module*
A30990	1/2" FKM: Chromex Fluid Module*
A30991	1/2" HNBR: Chromex Fluid Module*
A30992	1/2" TFE/P: Chromex Fluid Module*
A30960	12 VDC Fixed Speed Drive Module, Simplex
A30961	12 VDC Fixed Speed Drive Module, Duplex
A30963	12 VDC Variable Speed Drive Module, Simplex
A30964	12 VDC Variable Speed Drive Module, Duplex
A30965	115 VAC Fixed Speed Drive Module, Simplex
A30966	115 VAC Fixed Speed Drive Module, Duplex
A30968	115 VAC Fixed Speed Drive Module, Harrier AC, Simplex
A30969	115 VAC Fixed Speed Drive Module, Harrier AC, Duplex
A30950	115 VAC Variable Speed Drive Module, Simplex
A30951	115 VAC Variable Speed Drive Module, Duplex

* Includes ref. 106, 201-210, 215, and 216

Dimensions

G-Chem Fixed Speed Pump

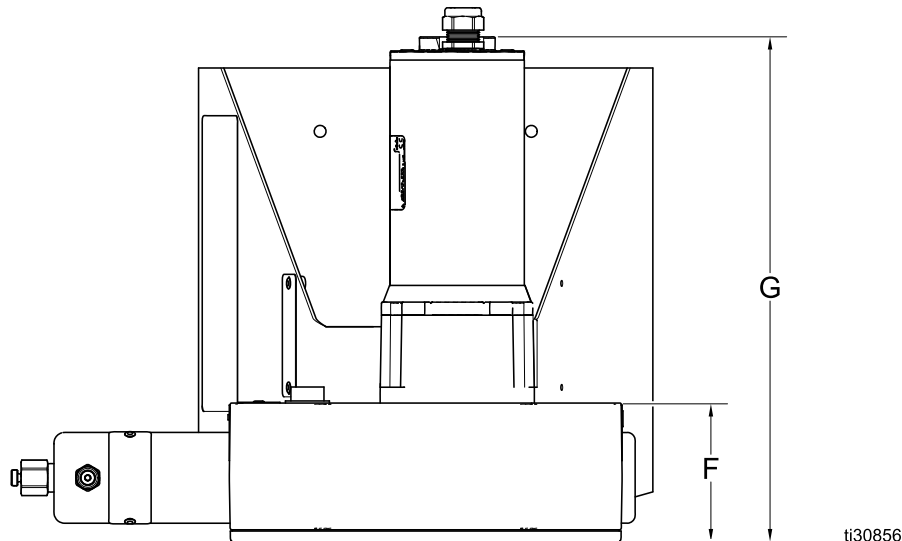
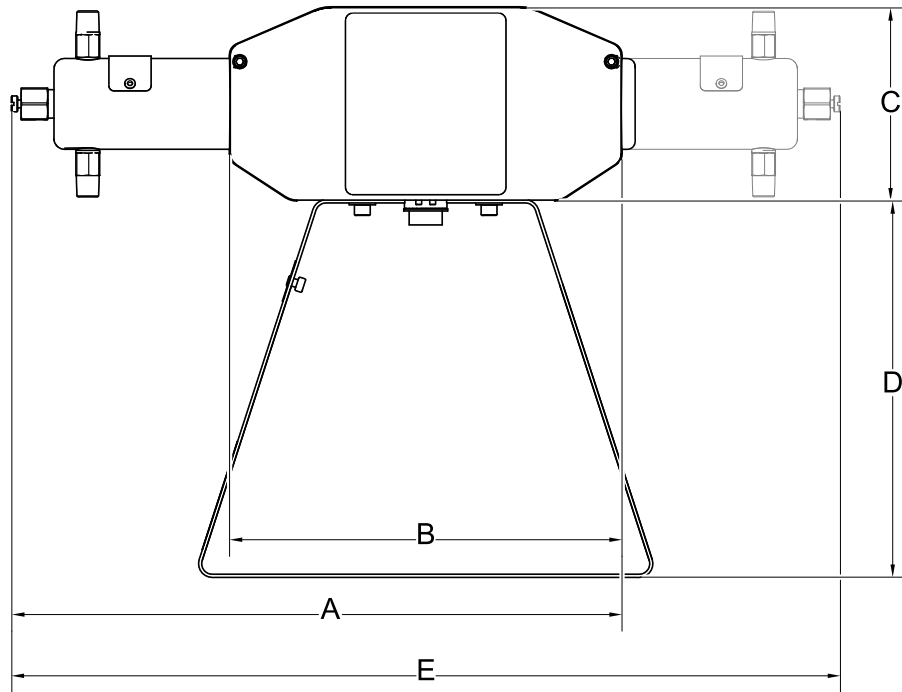

ti30856b

FIG. 13 G-Chem Pump Dimensions

A	B	C	D	E	F	G
13.8 in. (35.1 cm)	9.3 in. (23.6 cm)	4.6 in. (11.7 cm)	7.4 in. (18.8 cm)	18.4 in. (46.7 cm)	3.3 in. (8.4 cm)	12.7 in. (32.3 cm)

G-Chem Pump with Harrier AC

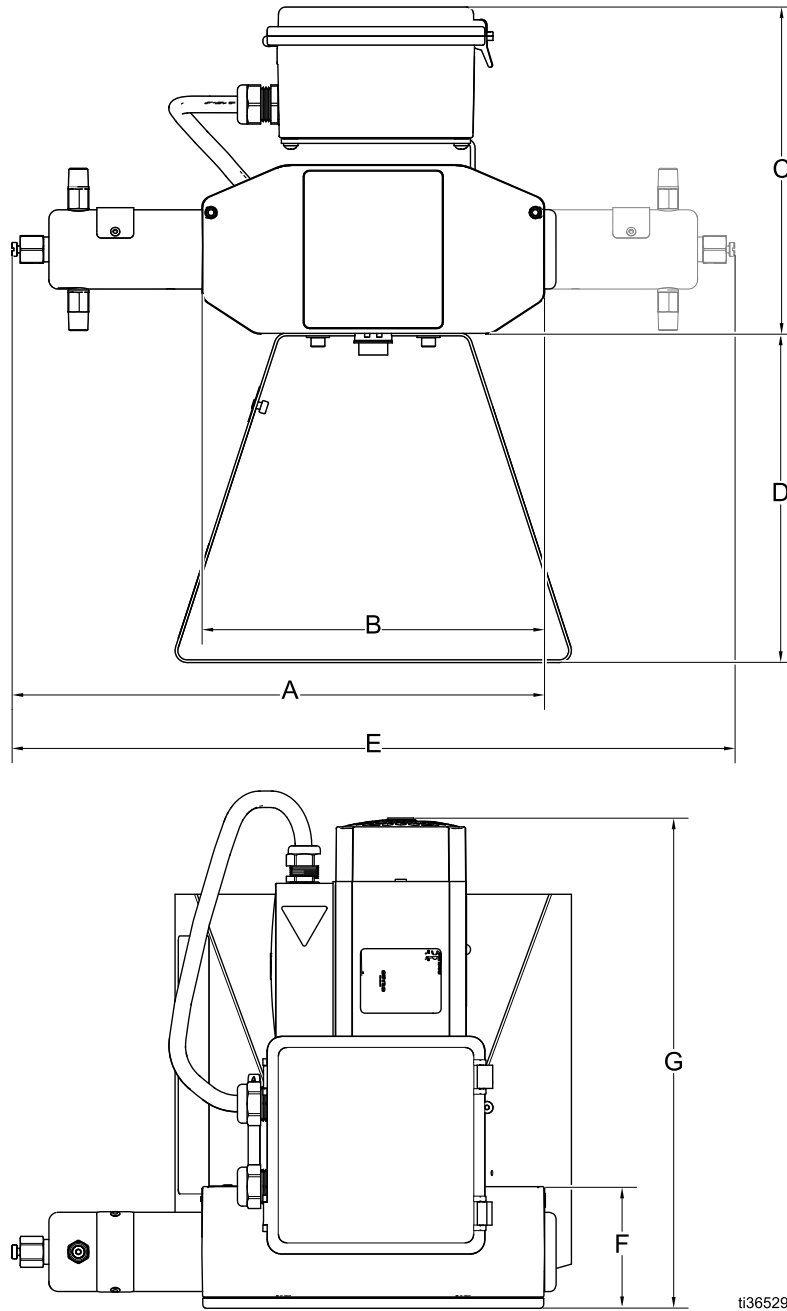

Fig. 14 G-Chem Pump with Harrier AC Dimensions

A	B	C	D	E	F	G
13.8 in. (35.1 cm)	9.3 in. (23.6 cm)	10.4 in. (26.4 cm)	7.4 in. (18.8 cm)	18.4 in. (46.7 cm)	3.3 in. (8.4 cm)	13.1 in. (33.3 cm)

G-Chem Variable Speed Pump

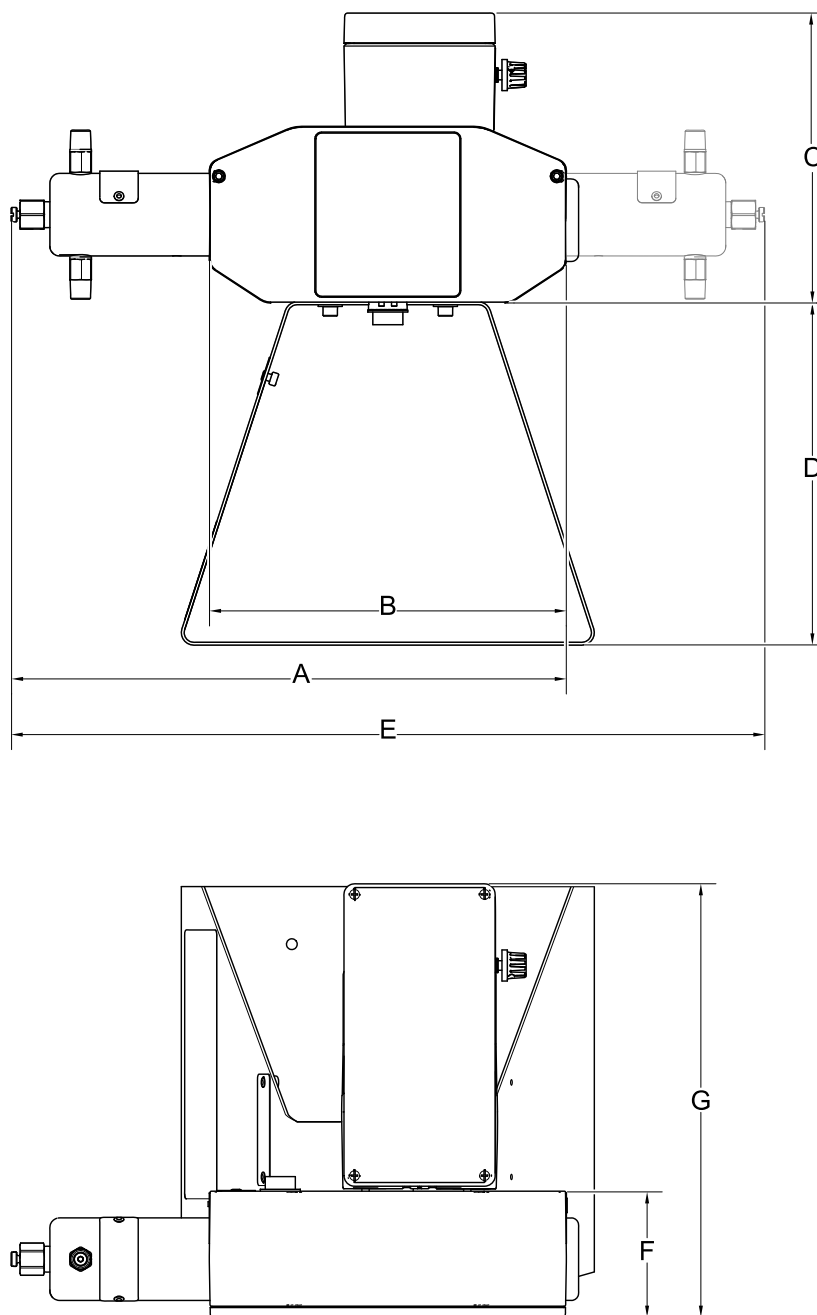

FIG. 15 G-Chem Pump Dimensions

ti36997a

A	B	C	D	E	F	G
13.8 in. (35.1 cm)	9.3 in. (23.6 cm)	7.5 in. (19.1 cm)	7.4 in. (18.8 cm)	18.4 in. (46.7 cm)	3.3 in. (8.4 cm)	12.7 in. (32.3 cm)

Mounting Holes

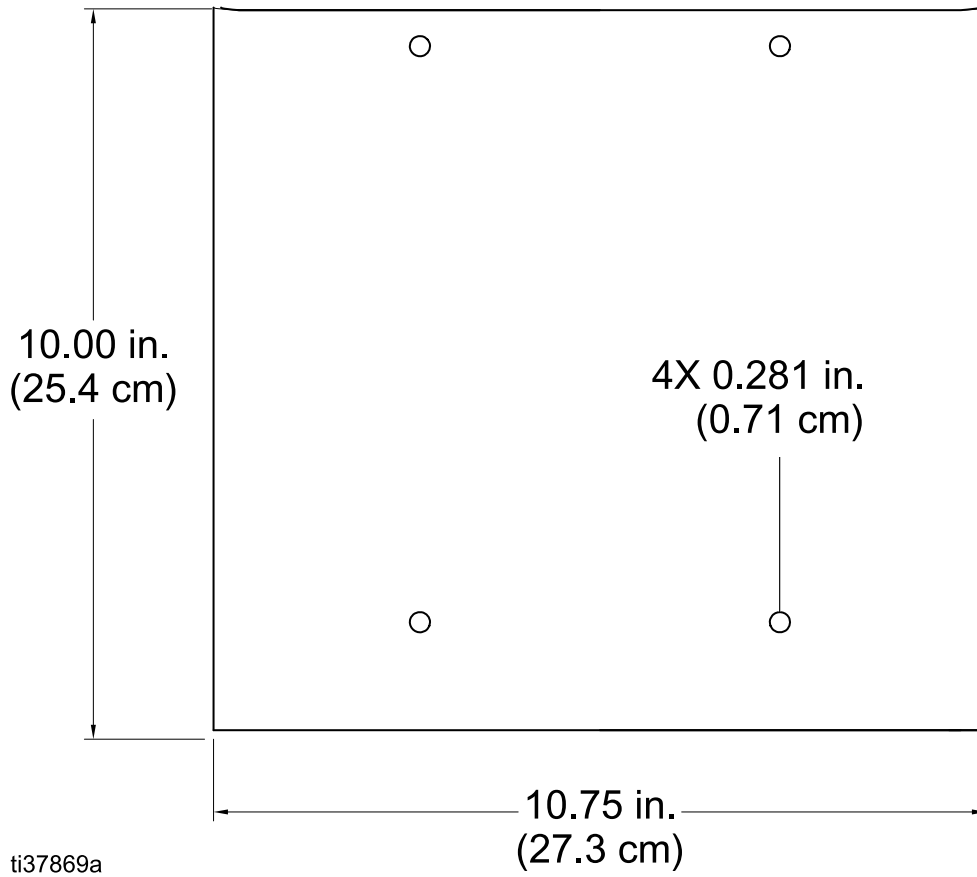

FIG. 16 Mounting Holes Dimensions

Performance Charts

G-Chem Pumps

1/4 Inch Plunger

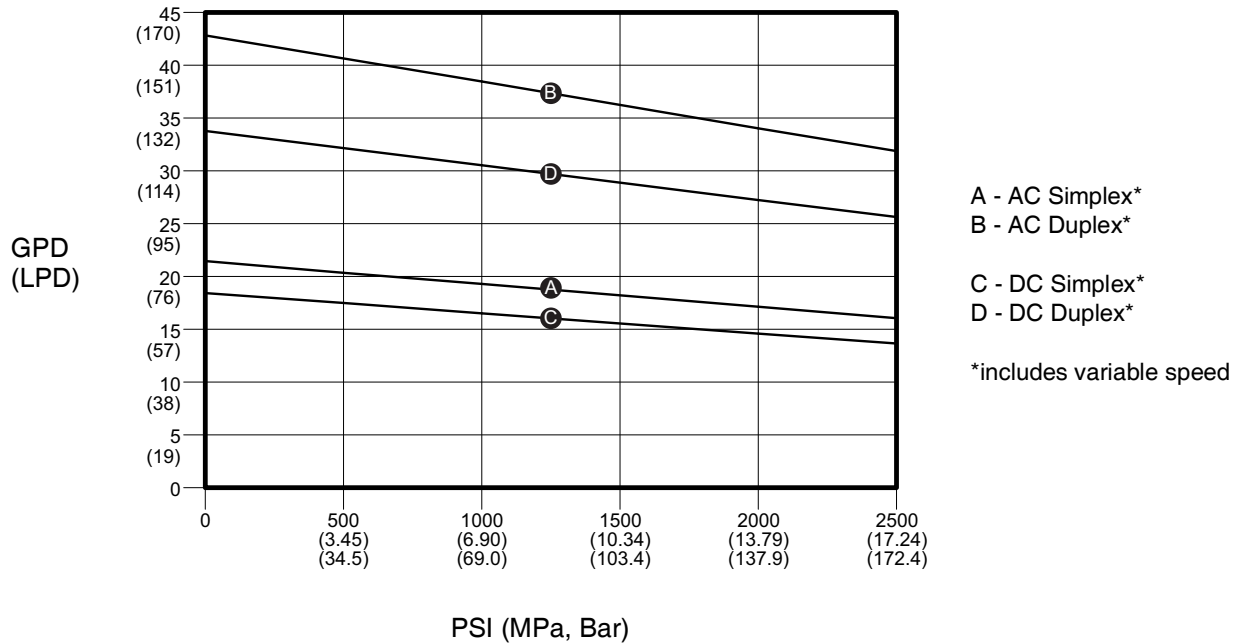

FIG. 17

3/8 Inch Plunger

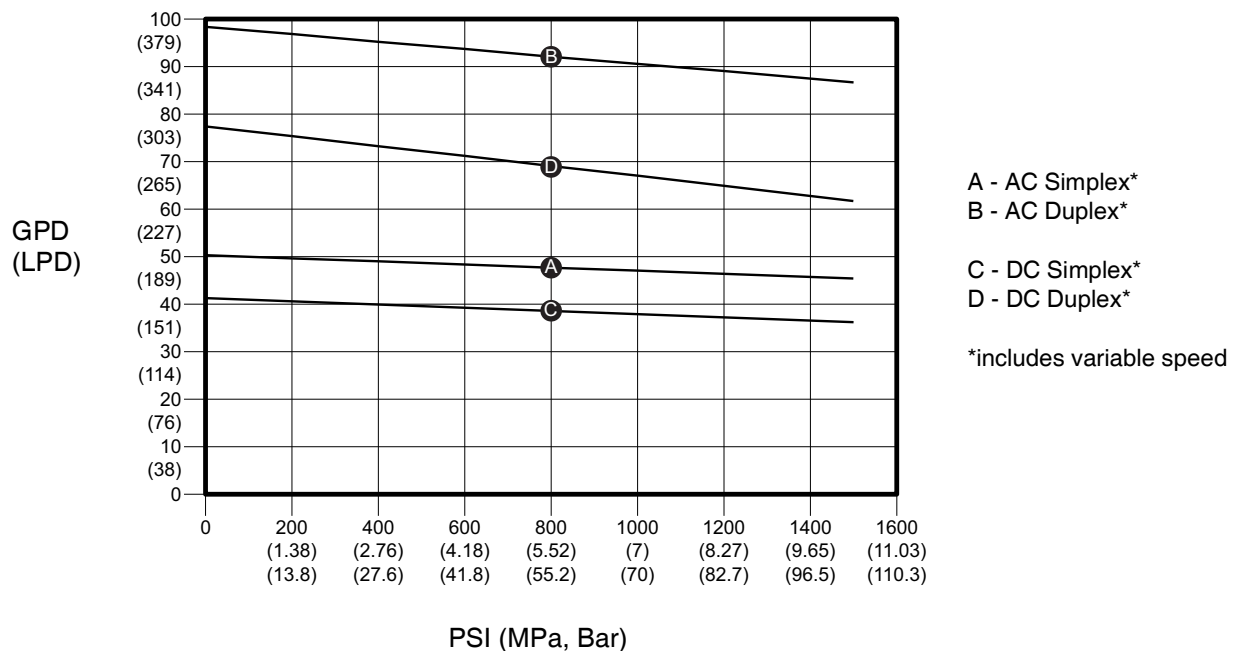

FIG. 18

1/2 Inch Plunger

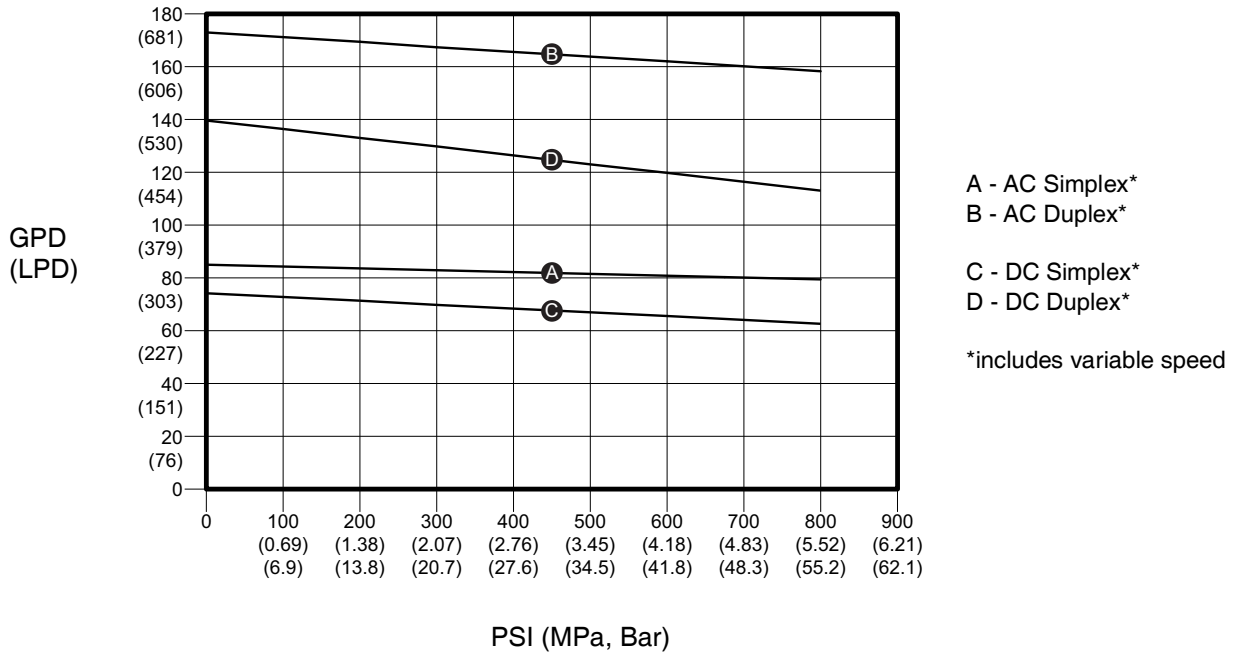

FIG. 19

Technical Specifications

G-Chem Chemical Injection Pump		
	US	Metric
Maximum fluid working pressure	Varies by model. See Models and Approvals on page 3.	
Input Voltage (by Drive Module, see pg 7)		
CI-12x-xx-x	12 VDC	
CI-1Ax-xx-x	115 VAC	
Maximum Input Current (by Drive Module, see pg 7)		
CI-12S-xx-x	11 A @ 12 VDC	
CI-1AE-xx-x	2.0 A @ 110 VAC Single Phase	
CI-12F-xx-x	16 A @ 12 VDC	
CI-1AG-xx-x	3.0 A @ 110 VAC Single Phase	
Power Connection	See Motor Electrical Connections on page 15.	
Environmental temperature range, ordinary location	-40°–131°F	-40°–55°C
Noise (dBa)		
Maximum sound pressure	<70 dBa	
Inlet/Outlet Sizes		
Fluid inlet size	1/4 in. npt(m)	
Fluid outlet size	1/4 in. npt(m)	
Materials of Construction		
Pump/Check Valve Seal Material	See Configuration Chart on page 6 for seal material. All other packing materials are UHMWPE and PTFE unless otherwise noted.	
Wetted Parts	See Configuration Chart on page 6 for plunger material. All other materials are 303 and 316 stainless steel unless otherwise noted.	
Weight		
G-Chem, 1 pump (Simplex)	21.5 lb.	9.7 kg
G-Chem, 1 pump (Simplex with controller)	22.9 lb.	10.4 kg
G-Chem, 2 pumps (Duplex)	26.0 lb.	11.8 kg
G-Chem, 2 pumps (Duplex with controller)	27.4 lb.	12.4 kg
G-Chem, variable speed, 1 pump (Simplex)	28.5 lb	12.9 kg
G-Chem, variable speed, 2 pumps (Duplex)	33.0 lb	15.0 kg

California Proposition 65

CALIFORNIA RESIDENTS

 **WARNING:** Cancer and reproductive harm — www.P65warnings.ca.gov.

Graco Standard Warranty

Graco warrants all equipment referenced in this document which is manufactured by Graco and bearing its name to be free from defects in material and workmanship on the date of sale to the original purchaser for use. With the exception of any special, extended, or limited warranty published by Graco, Graco will, for a period of twelve months from the date of sale, repair or replace any part of the equipment determined by Graco to be defective. This warranty applies only when the equipment is installed, operated and maintained in accordance with Graco's written recommendations.

This warranty does not cover, and Graco shall not be liable for general wear and tear, or any malfunction, damage or wear caused by faulty installation, misapplication, abrasion, corrosion, inadequate or improper maintenance, negligence, accident, tampering, or substitution of non-Graco component parts. Nor shall Graco be liable for malfunction, damage or wear caused by the incompatibility of Graco equipment with structures, accessories, equipment or materials not supplied by Graco, or the improper design, manufacture, installation, operation or maintenance of structures, accessories, equipment or materials not supplied by Graco.

This warranty is conditioned upon the prepaid return of the equipment claimed to be defective to an authorized Graco distributor for verification of the claimed defect. If the claimed defect is verified, Graco will repair or replace free of charge any defective parts. The equipment will be returned to the original purchaser transportation prepaid. If inspection of the equipment does not disclose any defect in material or workmanship, repairs will be made at a reasonable charge, which charges may include the costs of parts, labor, and transportation.

THIS WARRANTY IS EXCLUSIVE, AND IS IN LIEU OF ANY OTHER WARRANTIES, EXPRESS OR IMPLIED, INCLUDING BUT NOT LIMITED TO WARRANTY OF MERCHANTABILITY OR WARRANTY OF FITNESS FOR A PARTICULAR PURPOSE.

Graco's sole obligation and buyer's sole remedy for any breach of warranty shall be as set forth above. The buyer agrees that no other remedy (including, but not limited to, incidental or consequential damages for lost profits, lost sales, injury to person or property, or any other incidental or consequential loss) shall be available. Any action for breach of warranty must be brought within two (2) years of the date of sale.

GRACO MAKES NO WARRANTY, AND DISCLAIMS ALL IMPLIED WARRANTIES OF MERCHANTABILITY AND FITNESS FOR A PARTICULAR PURPOSE, IN CONNECTION WITH ACCESSORIES, EQUIPMENT, MATERIALS OR COMPONENTS SOLD BUT NOT MANUFACTURED BY GRACO. These items sold, but not manufactured by Graco (such as electric motors, switches, hose, etc.), are subject to the warranty, if any, of their manufacturer. Graco will provide purchaser with reasonable assistance in making any claim for breach of these warranties.

In no event will Graco be liable for indirect, incidental, special or consequential damages resulting from Graco supplying equipment hereunder, or the furnishing, performance, or use of any products or other goods sold hereto, whether due to a breach of contract, breach of warranty, the negligence of Graco, or otherwise.

FOR GRACO CANADA CUSTOMERS

The Parties acknowledge that they have required that the present document, as well as all documents, notices and legal proceedings entered into, given or instituted pursuant hereto or relating directly or indirectly hereto, be drawn up in English. Les parties reconnaissent avoir convenu que la rédaction du présente document sera en Anglais, ainsi que tous documents, avis et procédures judiciaires exécutés, donnés ou intentés, à la suite de ou en rapport, directement ou indirectement, avec les procédures concernées.

Graco Information

For the latest information about Graco products, visit www.graco.com.

For patent information, see www.graco.com/patents.

Revision G, May 2022

**MJ**
SYSTEMS

MJ Systems, LLC
Authorized Graco Distributors
TX - Off (281) 842-7600
LA - Off (504) 264-7744
www.mjsusa.com • sales@mjsusa.com