



FD Series Pulsation Dampener (ASME Design)



MJ Systems, LLC
Authorized FlowGuard Distributors
TX - Off (281) 842-7600
LA - Off (225) 726-7114
www.mjsusa.com • sales@mjsusa.com



PTFE Diaphragm Membrane Design for Improved Chemical Compatibility

Choice of steel or plastic shell materials

Fully customizable process connection (female thread, flange or hub)

Proprietary Charging Valve with Dual Seated, Poppet Design for Maximum Reliability

Blue Fluorocarbon Coated Stud-Bolts for Improved Protection in Harsh Environments

Certified Material Test Certificates

Welding Qualification and Procedures

ASME VIII, Div. 1 Design Calculations

Compliance to most project specifications

All designs are fully customizable including, but not limited to: pressure rating, connection size & type and materials of construction.

Standard non-wetted o-ring material options include: NBR, EPDM, Viton and PTFE encapsulated rubber. Kalrez o-rings are available upon request.

Common shell materials: 316 Stainless Steel, 316/316L Stainless Steel, Hastelloy C276, Monel, Titanium, Duplex Stainless Steel, Alloy 20 and Low Temperature Carbon Steel.

Plastic shell material options include PVC, Polypropylene and PVDF (Kynar). Plastic dampeners are limited to a pressure rating of 10 BarG at 30°C.

For quotation purposes only.

Data subject to change without notice.



FD Series Pulsation Dampener (ASME Design)



MJ Systems, LLC
 Authorized FlowGuard Distributors
 502 N 8th St • La Porte, TX 77571
 Off (281) 842-7600 • Fax (281) 842-7601
 www.mjsusa.com • sales@mjsusa.com

Standard Data for Dampener with Threaded Process Connection

Valid for A182 F316 (316 SS & 316/316L SS) with threaded process connection, design temp = 50°C.

Model Number	Volume (Liters)	ASME VIII		Standard Connection (NPT)	Outside Diameter (inches)	Overall Length (inches)	Approx. Weight (lbs)
		Pressure Rating (BarG)	(PSIG)				
FD-05	0.05	92	1334	1/2"	5.47	2.87	15
FD-10	0.10	91	1320	1/2"	6.18	3.43	21
FD-20	0.25	81	1175	1/2"	7.40	4.06	34
FD-30	0.50	65	943	1"	8.94	4.45	54
FD-40	1.0	65	943	1-1/2"	10.43	5.35	87
FD-50	2.0	48	696	1-1/2"	12.91	6.81	191
FD-60	5.0	48	696	2"	16.38	8.66	395

- * All weights and dimensions are approximate values for estimating purposes only.
- * Engineering Drawing to be supplied after receipt of purchase order with dimensions.
- * Please contact Flowguard USA with any questions or concerns.

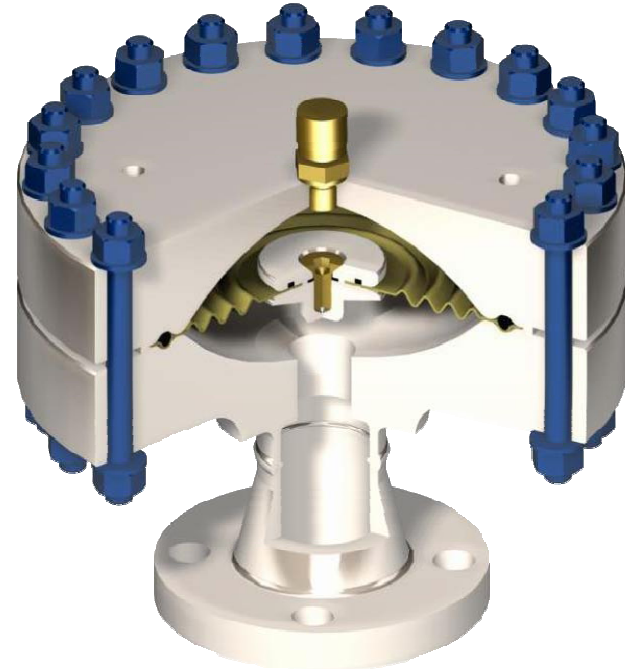

Estimated Flange Length & Weight Adder Table

Valid for A182 F316 (316 SS & 316/316L SS) with RF/WN or RTJ/WN flanges.

Flange Size	ANSI 150#	ANSI 300#	ANSI 600#	ANSI 900#	ANSI 1500#	ANSI 2500#
1/2"	1.9" 2 lbs	2.1" 2 lbs	2.1" 2 lbs	2.4" 5 lbs	2.4" 5 lbs	2.9" 7 lbs
3/4"	2.1" 2 lbs	2.25" 3 lbs	2.25" 4 lbs	2.75" 6 lbs	2.75" 6 lbs	3.1" 8 lbs
1"	2.2" 3 lbs	2.4" 4 lbs	2.4" 4 lbs	2.9" 9 lbs	2.9" 9 lbs	3.5" 12 lbs
1-1/2"	2.4" 4 lbs	2.7" 7 lbs	2.75" 8 lbs	3.25" 13 lbs	3.25" 13 lbs	4.4" 25 lbs
2"	2.5" 6 lbs	2.75" 9 lbs	2.9" 12 lbs	4" 25 lbs	4" 25 lbs	5" 42 lbs
3"	2.75" 10 lbs	3.1" 15 lbs	3.25" 23 lbs	4" 31 lbs	4.6" 48 lbs	6.6" 94 lbs
4"	3" 15 lbs	3.4" 25 lbs	4" 42 lbs	4.5" 53 lbs	4.9" 73 lbs	7.5" 145 lbs

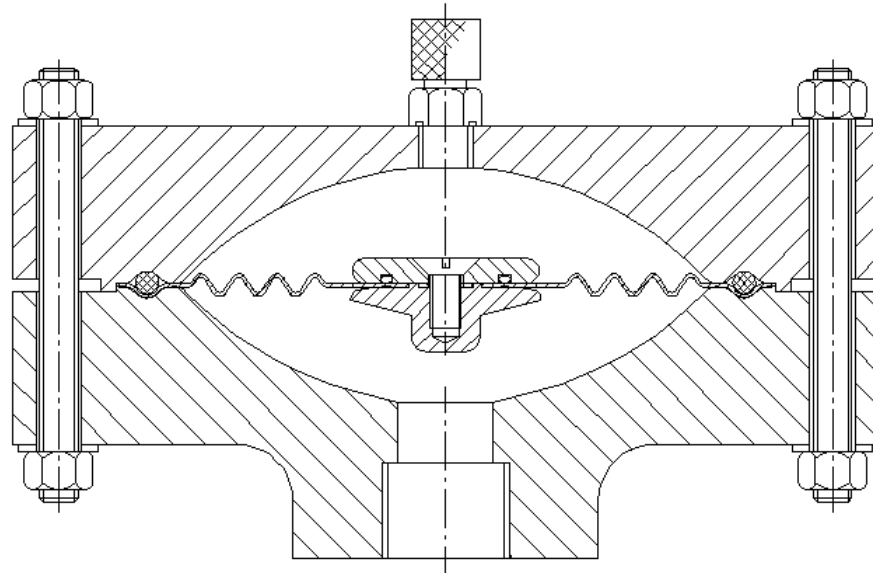

Unofficial drawing - For quotation purposes only.

Published April 2012. Data subject to change without notice.